



**SUPPORTING VALVE
SERIES**

配套阀门系列

软密封蝶阀

Soft seal butterfly valve

产品描述 Structural characteristics and usage

我公司研制的软密封中线对夹式蝶阀,双偏心法兰式蝶阀结构紧凑,90°回转开关轻松密封可靠使用寿命长被广泛用于水厂、电厂、钢厂、造纸、化工、饮食等系统供排水中作为调节和截止使用。

The soft sealing center line wafer butterfly valve developed by our company has a compact structure with a double eccentric flange butterfly valve. The 90° rotary switch is easy to seal, reliable, and has a long service life. It is widely used in water plants, power plants, steel mills, papermaking, chemical, catering and other systems for regulating and stopping water discharge.

产品编号编制方法 Product numbering method

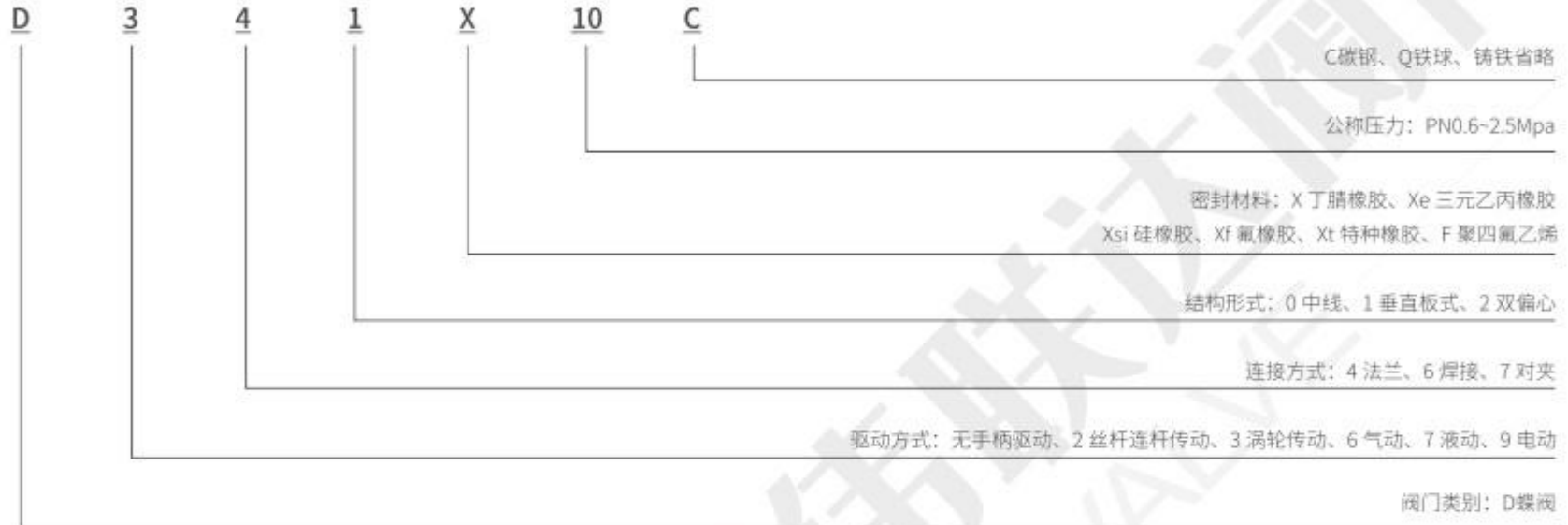

特点 Characteristic

- 本阀采用双偏心结构,具有越关越紧的密封功能,密封性能可靠。
- 密封副材料选用不锈钢和丁腈耐油橡胶配对,使用寿命长。
- 橡胶密封圈即可位于阀体上,也可以位于蝶板上,可适用不同特点的介质,供用户选择。
- 蝶板采用框架结构,强度高,迫流面积大,流阻小。
- 整体烤漆、能有效地防止锈蚀且只要更换密封阀座封阀座材料,就可使用于不同介质。
- 本阀具有双向密封功能,安装时不受介质流向的控制,也不受空间位置的影响,可在任何方向安装。
- 本阀结构独特,操作灵活,省力,方便。
- This valve adopts a double eccentric structure, with a sealing function that tightens as it closes, and reliable sealing performance.
- The sealing pair material is made of stainless steel and nitrile oil resistant rubber, with a long service life.
- The rubber sealing ring can be located on the valve body or on the butterfly plate, and can be suitable for different media characteristics for users to choose from. The butterfly plate adopts a frame structure with high strength, large forced flow area, and low flow resistance.
- The overall paint baking can effectively prevent rust and can be used in different media as long as the sealing valve seat material is replaced.
- This valve has a bidirectional sealing function, and is not controlled by the flow direction of the medium or affected by spatial position during installation. It can be installed in any direction. This valve has a unique structure, flexible operation, labor-saving, and convenient.

主要技术参数 Main technical parameters

公称通径DN(mm) Nominal diameter DN (mm)	50~2000		50~1600	
公称压力PN(MPa) Nominal pressure PN (MPa)	0.6	1.0	1.6	1.6
密封试验(MPa) Sealing test (MPa)	0.66	1.1	1.76	1.76
强度试验(MPa) Strength test (MPa)	0.9	1.5	2.4	2.4
适用温度 Applicable temperature	丁腈橡胶:-40°~90°C、氟橡胶-20°C~200°C Nitrile rubber: -40 °~90 ° C, fluorine rubber -20 ° C~200 ° C			
适用介质 Applicable medium	水、空气、天然气、油品及弱腐蚀性流体 Water, air, natural gas, oil products, and weakly corrosive fluids			
泄漏率 Leakage rate	符合GB/T13927-92标准 Complies with GB/T13927-92 standard			
驱动方式 Driving method	蜗轮传动、电动、气动液动 Worm gear transmission, electric, pneumatic hydraulic			

软密封中线蝶阀 Soft seal midline butterfly valve

主要零部件材料 Main component materials

零件名称 Part name	材料 Material Science
阀体 Valve body	WCB, QT450-10, HT200, HT250
蝶板 Disc	WCB, QT450-10, HT200, HT250
阀轴 Valve shaft	20Cr13
密封圈 Seal ring	丁腈耐油橡胶 Nitrile oil resistant rubber
填料 Filler	柔性石墨 Flexible graphite

执行标准 Executive standards

制造标准 Manufacturing standards	GB/T12238-89
法兰标准 Flange standard	GB9113-2000, GB17241 6-1998
结构长度标准 Structure length standard	GB12221-89
检验标准 Inspection standards	GB/T13927-92

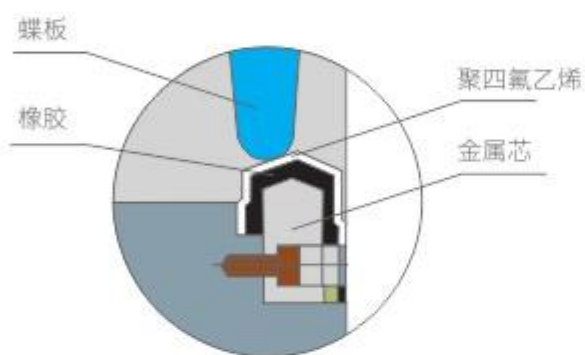

J形橡胶密封圈是将密封圈做在阀座上的一种密封形式。密封圈由金属母材外包覆聚四氟乙烯及特种硫化橡胶层组成。金属芯使蝶板有足够的刚性,聚四氟乙烯的软硬过渡,以及橡胶层的弹性补偿确保阀门的可靠密封。

J-shaped rubber sealing ring is a sealing form that places the sealing ring on the valve seat. The sealing ring is composed of a metal base material wrapped with polytetrafluoroethylene and a special vulcanized rubber layer. The metal core provides sufficient rigidity for the butterfly plate, the soft and hard transition of polytetrafluoroethylene, and the elastic compensation of the rubber layer ensure the reliable sealing of the valve.

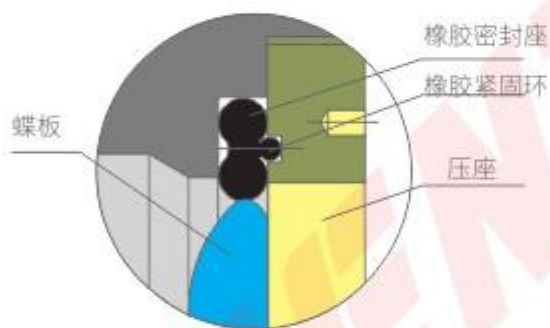

哑铃形橡胶密封圈是将密封圈做在阀座上的一种密封形式。哑铃形密封圈用O形橡胶紧自环限制,防止密封圈滑出沟槽。该结构密封性能特别好,使用寿命长,但只限于用于低压、常温的管路系统。密封圈更换容易,方便维修。

Dumbbell shaped rubber sealing ring is a sealing form that places the sealing ring on the valve seat. The dumbbell shaped sealing ring is restrained by O-ring rubber to prevent the sealing ring from sliding out of the groove. This structure has excellent sealing performance and long service life, but is only suitable for low-pressure and room temperature pipeline systems. The sealing ring is easy to replace and convenient for maintenance.

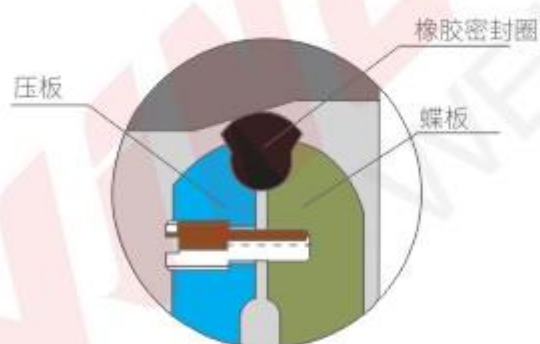

扇形弹性橡胶密封圈是将密封圈做在蝶板上的一种密封形式。密封副的配合可用螺栓调节,当阀门经过一段时间的使用后,密封面有一定量的磨损,此时拧紧螺栓挤压扇形弹性橡胶密封圈,补偿磨损余量,延长阀门寿命。

Fan shaped elastic rubber sealing ring is a sealing form that makes the sealing ring on the butterfly plate. The fit of the sealing ring can be adjusted with bolts. After a period of use of the valve, there is a certain amount of wear on the sealing surface. At this time, tightening the bolts compresses the fan-shaped elastic rubber sealing ring to compensate for any damage to the remaining capsule and extend the service life of the valve.

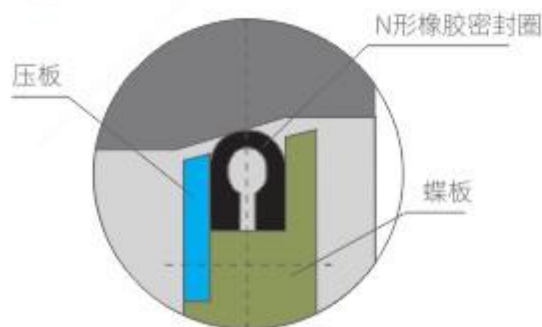

N形高弹性密封圈是将密封圈做在蝶板上的一种形式。目形高弹性密封圈用压板压住,并用螺栓固定,内部镶嵌金属钢丝索加强环,既有柔性又能防止密封圈径向胀缩。适合于中、高压管路系统。

N-shaped high elastic sealing ring is a form of sealing ring made on the butterfly plate. The mesh shaped high elastic sealing ring is pressed with a pressure plate and fixed with bolts. The metal wire rope reinforcement ring is embedded inside, which is both flexible and can prevent radial expansion and contraction of the sealing ring. Suitable for medium and high pressure pipeline systems.

D341X(FBGX)蜗轮传动软密封蝶阀

D341X (FBGX) worm gear transmission soft seal butterfly valve

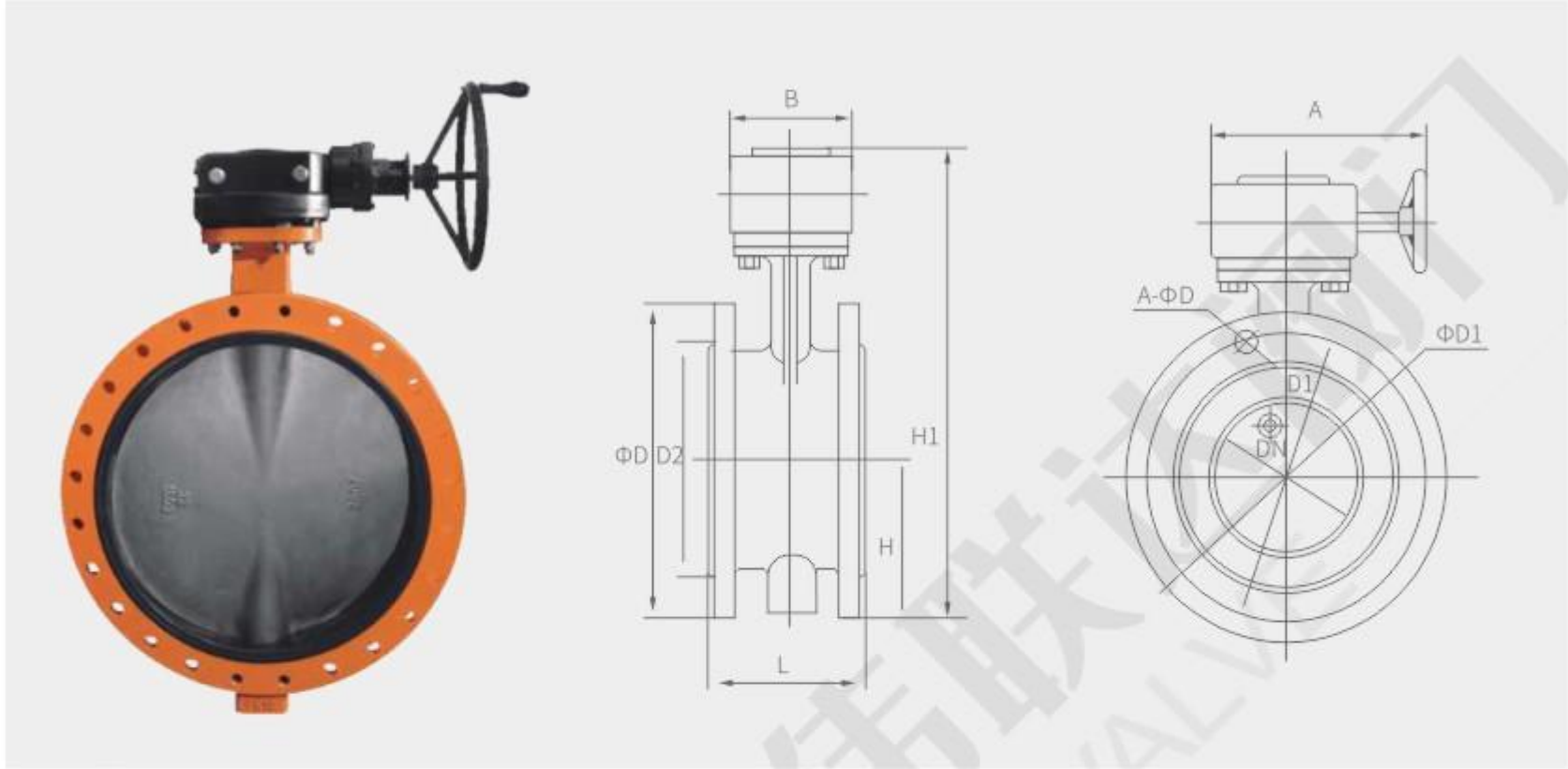

D341X (FBGX) 蜗轮传动软密封蝶阀主要外形连接尺寸

单位: mm

DN	主要外形尺寸 Main overall dimensions					法兰尺寸和螺孔尺寸 Flange size and screw hole size											
	L	H	H1	A	B	0.6MPa				1.0MPa				1.6MPa			
						D	D1	D2	n-d	D	D1	D2	n-d	D	D1	D2	n-d
50	108	82.5	306	80	80	140	110	88	4-14	165	125	99	4-18	165	125	99	4-18
65	112	92.5	321	80	80	160	130	108	4-14	185	145	118	4-18	185	145	118	4-18
80	114	100	346	80	80	190	150	124	4-18	200	160	132	8-18	200	160	132	8-18
100	127	110	387	95	95	210	170	144	4-18	220	180	156	8-18	220	180	156	8-18
125	140	125	411	95	95	240	200	174	8-18	250	210	184	8-18	250	210	184	8-18
150	140	142.5	447	95	95	265	225	199	8-18	285	240	211	8-22	285	240	211	8-22
200	152	170	607	190	308	320	280	254	8-18	340	295	266	8-22	340	295	266	12-22
250	165	192.5	688	190	308	375	335	309	12-18	395	350	319	12-22	405	355	319	12-26
300	178	222.5	742	190	308	440	395	363	12-22	445	400	370	12-22	460	410	370	12-26
350	190	252.5	797	190	308	490	445	413	12-22	505	460	429	16-22	520	470	429	16-26
400	216	282.5	930	270	466	540	495	463	16-22	565	515	480	16-26	580	525	480	16-30
450	222	307.5	975	270	466	595	550	518	16-22	615	565	530	20-26	640	585	548	20-30
500	229	335	1065	270	466	645	600	568	20-22	670	620	582	20-26	715	650	609	20-33
600	267	390	1225	457	625	755	705	667	20-26	780	725	682	20-30	840	770	720	20-36
700	292	447.5	1343	457	625	860	810	772	24-26	895	840	794	24-30	910	840	794	24-36
800	318	507.5	1436	457	625	975	920	878	24-30	1015	950	901	24-33	1025	950	901	24-39
900	330	557.5	1616	598	853	1075	1020	978	24-30	1115	1050	1001	28-33	1125	1050	1001	28-39
1000	410	615	1711	598	853	1175	1120	1078	28-3	1230	1160	1112	28-36	1255	1170	1112	28-42
1200	470	727.5	1971	598	853	1405	1340	1295	32-33	1455	1380	1328	32-39	1485	1390	1328	32-48
1400	530	837.5	2218	860	1345	1630	1560	1510	36-36	1675	1590	1530	36-42	1685	1590	1530	36-48
1600	600	957.5	2578	860	1345	1830	1760	1710	40-36	1915	1820	1750	40-48	1930	1820	1750	40-56
1800	670	1057.5	2689	860	1345	2045	1970	1918	44-39	2115	2020	1950	44-48	2130	2020	1950	44-56
2000	760	1162.5	3022	952	1592	2265	2180	2125	48-42	2325	2230	2150	48-48	2345	2230	2150	48-62

D641X(FBPX)气动软密封蝶阀 D641X (FBPX) pneumatic soft seal butterfly valve

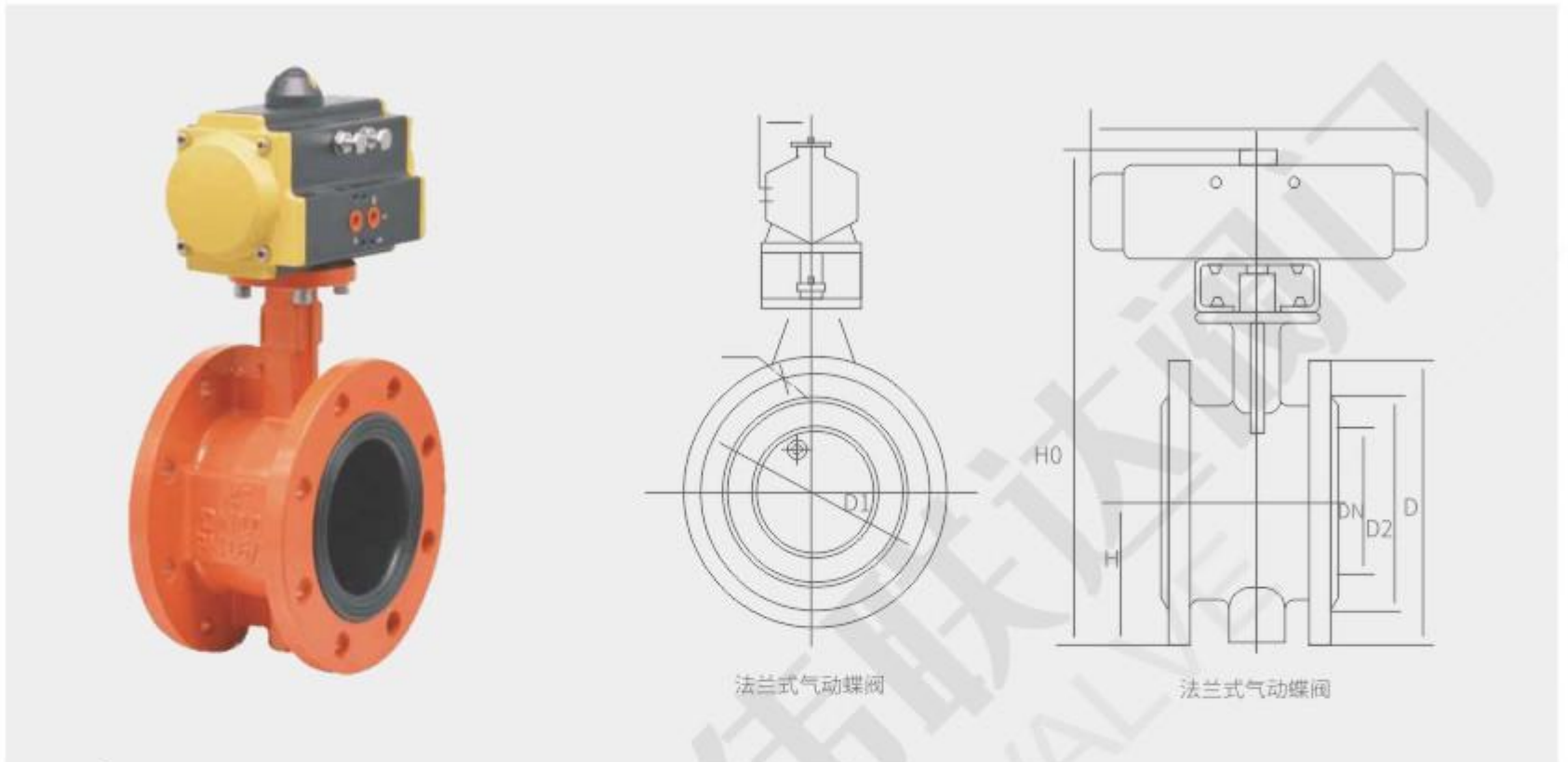

D641X - ⁶/₁₀ / ₁₆ 气动软密封蝶阀主要外形连接尺寸

单位: mm

DN	主要外形尺寸 Main overall dimensions					法兰尺寸和螺孔尺寸 Flange size and screw hole size											
	L	H	H0	A	B	0.6MPa				1.0MPa				1.6MPa			
						D	D1	D2	n-d	D	D1	D2	n-d	D	D1	D2	n-d
50	108	82.5	338	180	65	140	110	88	4-14	165	125	99	4-18	165	125	99	4-18
65	112	92.5	358	180	65	160	130	108	4-14	185	145	118	4-18	185	145	118	4-18
80	114	100	413	245	72	190	150	124	4-18	200	160	132	8-18	200	160	132	8-18
100	127	110	428	240	72	210	170	144	4-18	220	180	156	8-18	220	180	156	8-18
125	140	125	444	240	72	240	200	174	8-18	250	210	184	8-18	250	210	184	8-18
150	140	142.5	553	350	93	265	225	199	8-18	285	240	211	8-22	285	240	211	8-22
200	152	170	678	350	93	320	280	254	8-18	340	295	266	8-22	340	295	266	12-22
250	165	197.5	742	550	350	375	335	309	12-18	395	350	319	12-22	405	355	319	12-26
300	178	222.5	803	600	350	440	395	363	12-22	445	400	370	12-22	460	410	370	12-26
350	190	252.5	866	600	350	490	445	413	12-22	505	460	429	16-22	520	470	429	16-26
400	216	282.5	940	600	350	540	495	463	16-22	565	515	480	16-26	580	525	480	16-30
450	222	307.5	995	750	380	595	550	518	16-22	615	565	530	20-26	640	585	548	20-30
500	229	335	1058	750	380	645	600	568	20-22	670	620	582	20-26	715	650	609	20-33
600	267	390	1163	750	380	755	705	667	20-26	780	725	682	20-30	840	770	720	20-36
700	292	447.5	1283	750	380	860	810	772	24-26	895	840	794	24-30	910	840	794	24-36
800	318	507.5	1398	750	380	975	920	878	24-30	1015	950	901	24-33	1025	950	901	24-39
900	330	557.5	1498	1250	380	1075	1020	978	24-30	1115	1050	1001	28-33	1125	1050	1001	28-39
1000	410	615	1608	1500	580	1175	1120	1078	28-3	1230	1160	1112	28-36	1255	1170	1112	28-42
1200	470	727.5	1876	1500	580	1405	1340	1295	32-33	1455	1380	1328	32-39	1485	1390	1328	32-48

中线对夹软密封蝶阀

Centerline wafer soft seal butterfly valve



主要零部件材料 Main component materials

零件名称 Part name	材料 Material
阀体 Valve body	WCB、Q T450-10、CF8、Al
蝶板 Disc	WCB、Q T450-10、CF8、Al
阀轴 Valve shaft	20Cr13
密封圈 Seal ring	EPDM、NBR

执行标准 Executive standards

制造标准 Manufacturing standards	GB/T12238-89
法兰标准 Flange standard	GB9113-2000、GB17241 6-1998
结构长度标准 Structure length standard	GB12221-89
检验标准 Inspection standards	GB/T13927-92

主要技术参数 Main technical parameters

公称通径DN(mm) Nominal diameter DN (mm)	40~1200
公称压力PN(MPa) Nominal pressure PN (MPa)	1.0 1.6
密封试验(MPa) Sealing test (MPa)	1.1 1.76
强度试验(MPa) Strength test (MPa)	1.5 2.4
适用温度 Applicable temperature	-10°C~80°C
适用介质 Applicable medium	水、空气、天然气、食品、药品、各种油类、酸类 Water, air, natural gas, food, medicine, various oils, acids
驱动方式 Driving method	手柄、蜗轮蜗杆传动、电动、气动 Handle, worm gear drive, electric, pneumatic

产品特点 Product Features

- 连接键精度高、强度大,适用安装手柄、蜗轮蜗杆传动、电动和气动各种控制装置;
- 阀杆整体性好,便于控制阀板启闭,具有良好的密封性能,阀杆周围无泄露现象;
- 阀板经抛光处理,与阀座配合精度高无干涉现象,操作力矩小,阀座使用寿命长,阀板外形尺寸精确,截流后密封性好;
- 止推轴承防止阀杆超载,阀杆密封不易变形,避免阀杆泄露现象。

- The connection key has high precision and strength, suitable for installing various control devices such as handles, worm gear and worm drive, electric and pneumatic;
- The valve stem has good integrity and is easy to control the opening and closing of the valve plate. It has good sealing performance and there is no leakage around the valve stem;
- The valve plate has been polished and has high precision in fitting with the valve seat, resulting in interference. The operating torque is small, the valve seat has a long service life, and the valve plate has precise external dimensions. After interception, the sealing performance is good;
- Thrust bearings prevent overloading of the valve stem, prevent deformation of the valve stem seal, and prevent valve stem leakage.

中线对夹软密封蝶阀 Centerline wafer soft seal butterfly valve

密封副材质表 Sealing Material List

材料	适用温度°C	介质类型及适用程度														特点	价位
		淡水	海水	盐类	强碱	弱碱	强酸	弱酸	天然气	醇类	空气	蒸汽	油类	食品			
丁腈橡胶	-40~93°C	★	★	★	▲	★	●	▲	★	■	★	●	★	▲	耐油	低	
三元乙丙	-50~135°C	★	★	★	★	★	■	★	▲	▲	★	★	■	★	耐老化	较低	
天然橡胶	-20~80°C	★	★	★	★	★	■	▲	●	■	★	●	●	●	高弹性	低	
氯丁橡胶	-40~82°C	★	★	▲	★	★	●	■	●	■	★	●	●	▲	耐光、耐老化	低	
硅橡胶	-65~210°C	★	★	▲	●	▲	●	▲	★	▲	★	★	■	■	耐高温	高	
氟橡胶	-23~204°C	★	★	★	■	★	■	★	★	■	★	★	★	★	耐高温、耐腐蚀	昂贵	
聚四氟乙烯	-200~160°C	★	★	★	★	★	★	★	★	★	★	★	★	★	耐强腐蚀、耐热	昂贵	
球铁镀铬	-30~350°C	▲	▲	■	●	■	●	■	▲	★	▲	★	★	■	耐热	低	
球铁尼龙覆层	-30~95°C	★	★	★	★	★	★	★	★	■	★	●	★	★	耐腐蚀、耐磨、减少摩擦	较低	
球铁氯化聚醚覆层	-30~130°C	★	★	★	★	★	★	★	★	★	★	■	★	★	耐强腐蚀、耐磨	较低	
球铁四氟覆层	-30~160°C	★	★	★	★	★	★	★	★	★	★	★	★	★	耐强腐蚀、耐热	昂贵	
铝青铜	-273~232°C	★	◆	■	●	■	●	▲	★	★	★	★	★	■	耐热、耐腐蚀	高	
不锈钢	-268~538°C	★	◆	■	■	▲	■	★	★	★	★	★	★	★	耐高温、耐腐蚀	高	
碳钢镀铬	-29~425°C	▲	●	■	●	■	■	■	▲	★	▲	★	★	■	耐高温	较低	

注:符号说明:★非常适用;▲(适用)◆(适用)(其中◆当流速大于1.5M/S时不适用);■有限适用;●不适用。

曲线流量图 Curve flow chart

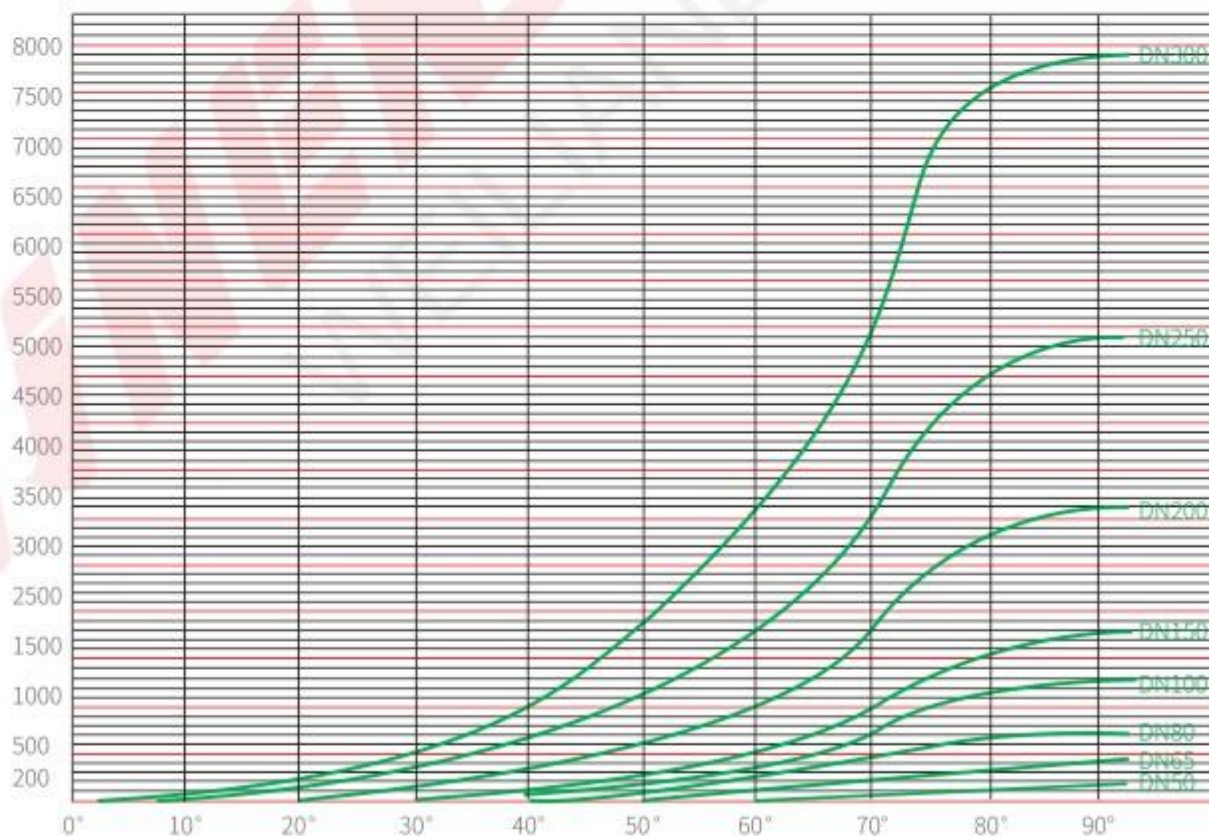

Cv值定义

当阀门全开时,阀门两端压差1磅/英寸²,
流体用60°F的清水时,通过阀门的美加仑/分的流量数。

$$Cv = Q \sqrt{\frac{G}{\Delta P}}$$

Q: 最大流量(美加仑/分)

G: 比重(水=1)

ΔP: 压力降(磅/英寸²)

D71X对夹软密封蝶阀
D71X wafer soft seal butterfly valve

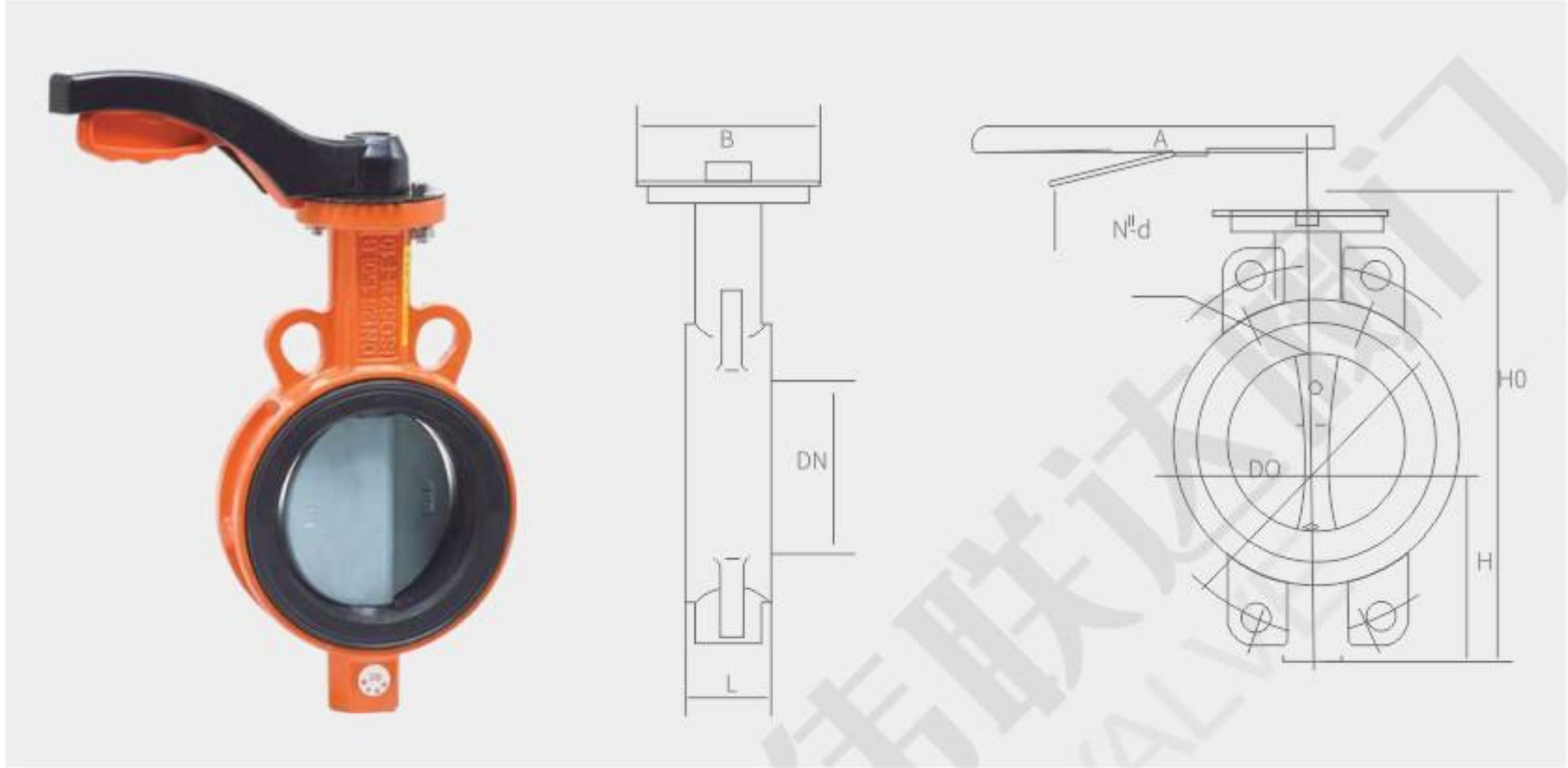

D71X-⁶/₁₀对夹软密封蝶阀主要外形连接尺寸

单位: mm

DN	L	H	H0	A	B	0.6MPa		1.0MPa		1.6 MPa	
						DO	n-d	DO	n-d	DO	n-d
50	43	63	235	270	110	110	4-14	125	4-18	125	4-18
65	46	70	250	270	110	130	4-14	145	4-18	145	4-18
80	46	83	275	270	110	150	4-18	160	8-18	160	8-18
100	52	105	316	270	110	170	4-18	180	8-18	180	8-18
125	56	115	340	310	110	200	8-18	210	8-18	210	8-18
150	56	137	376	310	110	225	8-18	240	8-22	240	8-22
200	60	164	430	353	150	280	8-18	295	8-22	295	12-22
250	68	206	499	353	150	335	12-18	350	12-22	355	12-26
300	78	230	570	380	150	395	12-22	400	12-22	410	12-26

D371X对夹蜗轮软密封蝶阀 D371X wafer worm gear soft seal butterfly valve

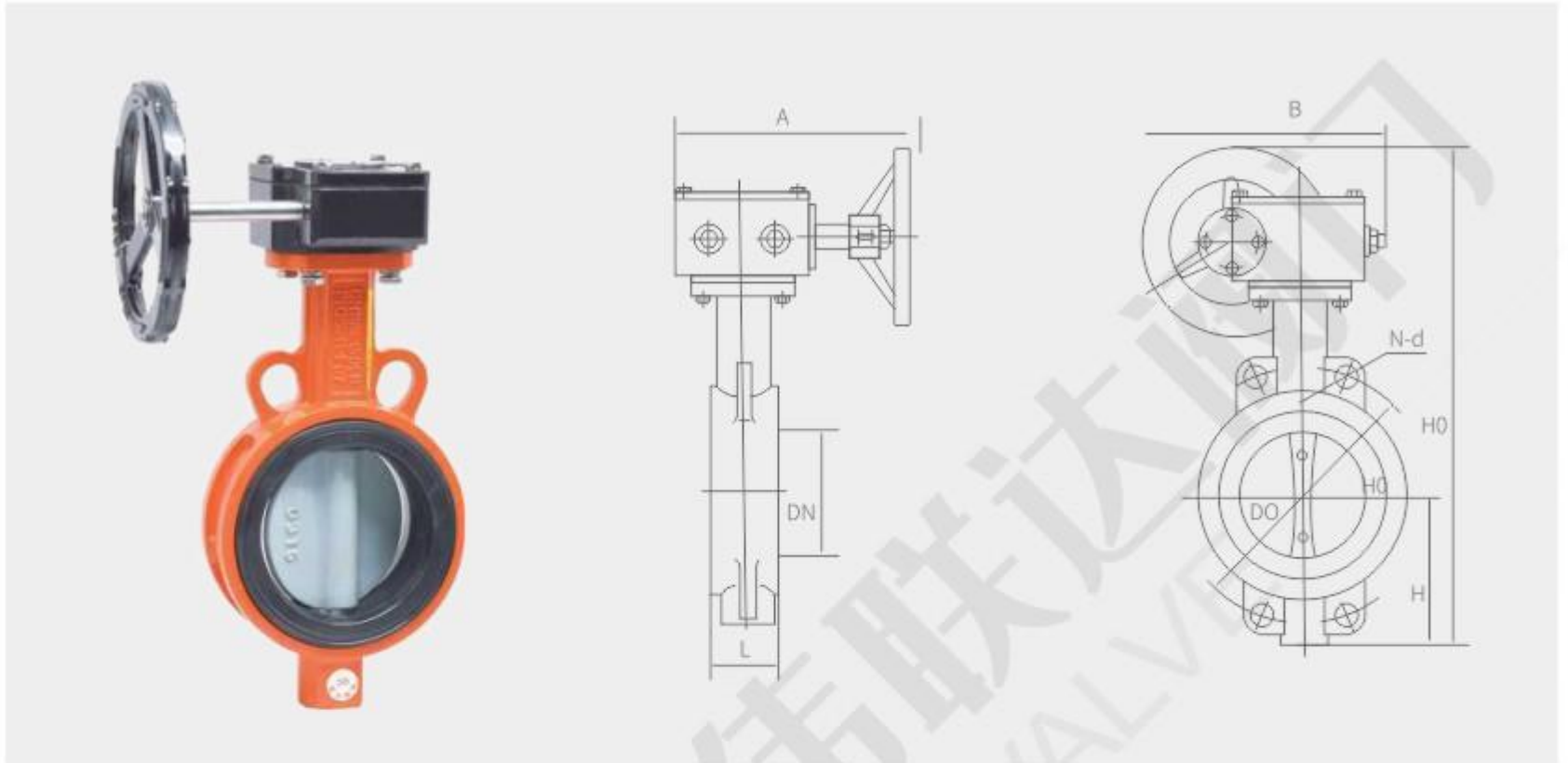

D371X-⁶/₁₀ 对夹蜗轮软密封蝶阀主要外形连接尺寸

单位: mm

DN	主要外形尺寸 Main overall dimensions					主要连接尺寸 Main connection dimensions					
						0.6 MPa		1.0 MPa		1.6 MPa	
	L	H	HO	A	B	DO	n-d	DO	n-d	DO	n-d
50	43	63	306	180	200	110	4-14	125	4-18	125	4-18
65	46	70	321	180	200	130	4-14	145	4-18	145	4-18
80	46	83	346	180	200	150	4-18	160	8-18	160	8-18
100	52	105	387	180	200	170	4-18	180	8-18	180	8-18
125	56	115	411	180	200	200	8-18	210	8-18	210	8-18
150	56	137	447	270	280	225	8-18	240	8-22	240	8-22
200	60	164	572	270	280	280	8-18	295	8-22	295	12-22
250	68	206	646	270	280	335	12-18	350	12-22	355	12-26
300	78	230	738	380	420	395	12-22	400	12-22	410	12-26
350	78	248	761	380	420	445	12-22	460	16-22	470	16-26
400	102	289	877	450	470	495	16-22	515	16-26	525	16-30
450	114	320	938	480	490	550	16-22	565	20-26	585	20-30
500	127	343	993	480	490	600	20-22	620	20-26	650	20-33
600	154	413	1131	480	490	705	20-26	725	20-30	770	20-36
700	165	478	1476	640	660	810	24-26	840	24-30	840	24-36
800	190	525	1533	640	660	920	24-30	950	24-33	950	24-39
900	203	585	1655	750	860	1020	24-30	1050	28-33	1050	28-39
1000	216	640	1765	850	900	1120	28-30	1160	28-36	1170	28-42
1200	254	755	1995	850	900	1340	32-33	1380	32-39	1390	32-48

D671X对夹气动软密封蝶阀
D671X wafer pneumatic soft sealing butterfly valve

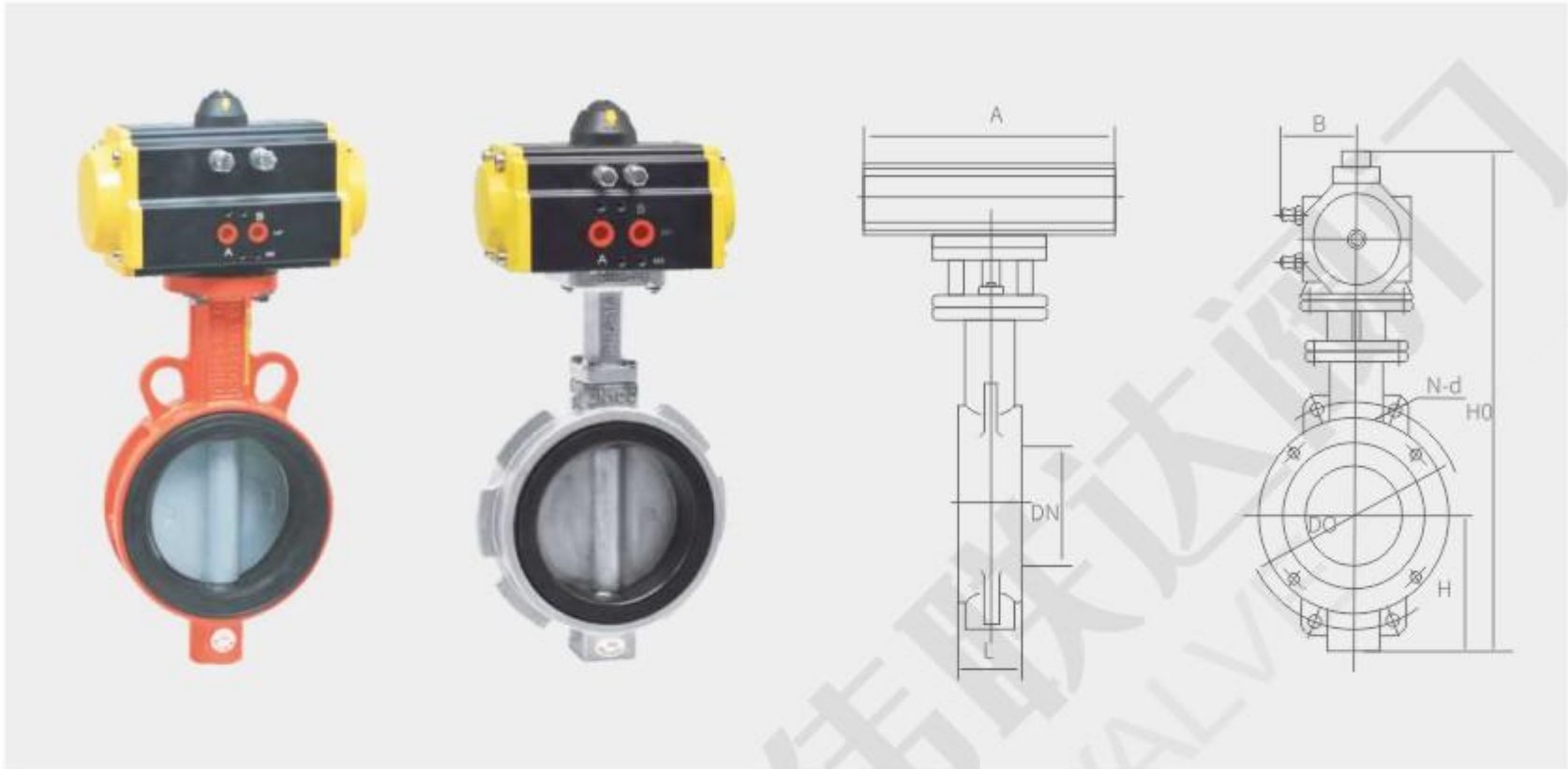

D671X-⁶/₁₀/₁₆ 对夹气动软密封蝶阀主要外形连接尺寸

单位: mm

DN	主要外形尺寸 Main overall dimensions					主要连接尺寸 Main connection dimensions					
						0.6 MPa		1.0 MPa		1.6 MPa	
	L	H	HO	A	B	DO	n-d	DO	n-d	DO	n-d
50	43	63	315	180	65	110	4-14	125	4-18	125	4-18
65	46	70	330	180	65	130	4-14	145	4-18	145	4-18
80	46	83	390	245	72	150	4-18	160	8-18	160	8-18
100	52	105	431	240	72	170	4-18	180	8-18	180	8-18
125	56	115	455	240	72	200	8-18	210	8-18	210	8-18
150	56	137	626	350	93	225	8-18	240	8-22	240	8-22
200	60	164	720	350	93	280	8-18	295	8-22	295	12-22
250	68	206	800	550	350	335	12-18	350	12-22	355	12-26
300	78	230	860	600	350	395	12-22	400	12-22	410	12-26
350	78	248	883	600	350	445	12-22	460	16-22	470	16-26
400	102	289	972	600	350	495	16-22	515	16-26	525	16-30
450	114	320	1043	750	380	550	16-22	565	20-26	585	20-30
500	127	343	1098	750	380	600	20-22	620	20-26	650	20-33
600	154	413	1236	750	380	705	20-26	725	20-30	770	20-36
700	165	478	1431	750	380	810	24-26	840	24-30	840	24-36
800	190	525	1488	750	380	920	24-30	950	24-33	950	24-39
900	203	620	1615	1250	380	1020	24-30	1050	28-33	1050	28-39
1000	216	725	1765	1500	580	1120	28-30	1160	28-36	1170	28-42
1200	254	780	1976	1500	580	1340	32-33	1380	32-39	1390	32-48

D971X对夹电动软密封蝶阀 D971X wafer electric soft seal butterfly valve

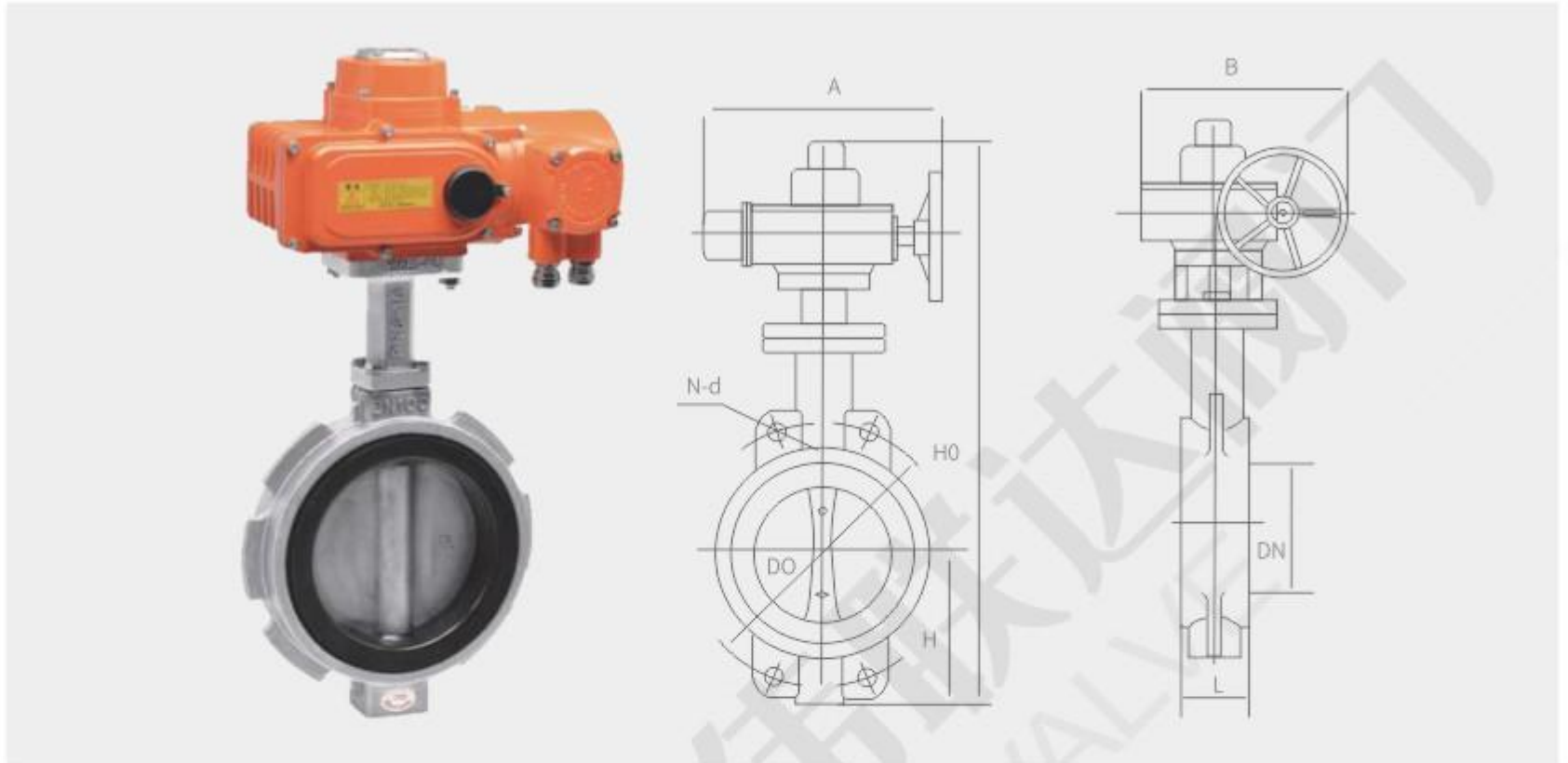

D971X-⁶/₁₀ 对夹电动软密封蝶阀主要外形连接尺寸
16

单位: mm

DN	主要外形尺寸 Main overall dimensions					主要连接尺寸 Main connection dimensions					
						0.6 MPa		1.0 MPa		1.6 MPa	
	L	H	HO	A	B	DO	n-Φd	DO	n-Φd	DO	n-Φd
50	43	63	438	125	125	110	4-14	125	4-18	125	4-18
65	46	70	453	125	125	130	4-14	145	4-18	145	4-18
80	46	83	478	125	125	150	4-18	160	8-18	160	8-18
100	52	105	519	125	125	170	4-18	180	8-18	180	8-18
125	56	115	713	325	245	200	8-18	210	8-18	210	8-18
150	56	137	749	325	245	225	8-18	240	8-22	240	8-22
200	60	164	843	325	245	280	8-18	295	8-22	295	12-22
250	68	206	947	363	313	335	12-18	350	12-22	355	12-26
300	78	230	1013	363	313	395	12-22	400	12-22	410	12-26
350	78	248	1046	363	313	445	12-22	460	16-22	470	16-22
400	102	289	1135	363	313	495	16-22	515	16-26	525	16-30
450	114	320	1328	465	439	550	16-22	565	20-26	585	20-30
500	127	343	1226	546	481	600	20-22	620	20-26	650	20-33
600	154	413	1394	546	556	705	20-26	725	20-30	770	20-36
700	165	478	1534	546	556	810	24-26	840	24-30	840	24-36
800	190	525	1159	546	556	920	24-30	950	24-33	950	24-39
900	203	585	1748	617	706	1020	24-30	1050	28-33	1050	28-39
1000	216	640	1805	632	706	1120	28-30	1160	28-36	1170	28-42
1200	254	755	2035	632	706	1340	32-33	1380	32-39	1390	32-48

Z45X(RVHX)暗杆弹性座封闸阀

Z45X (RVHX) non rising stem elastic seat sealing gate valve

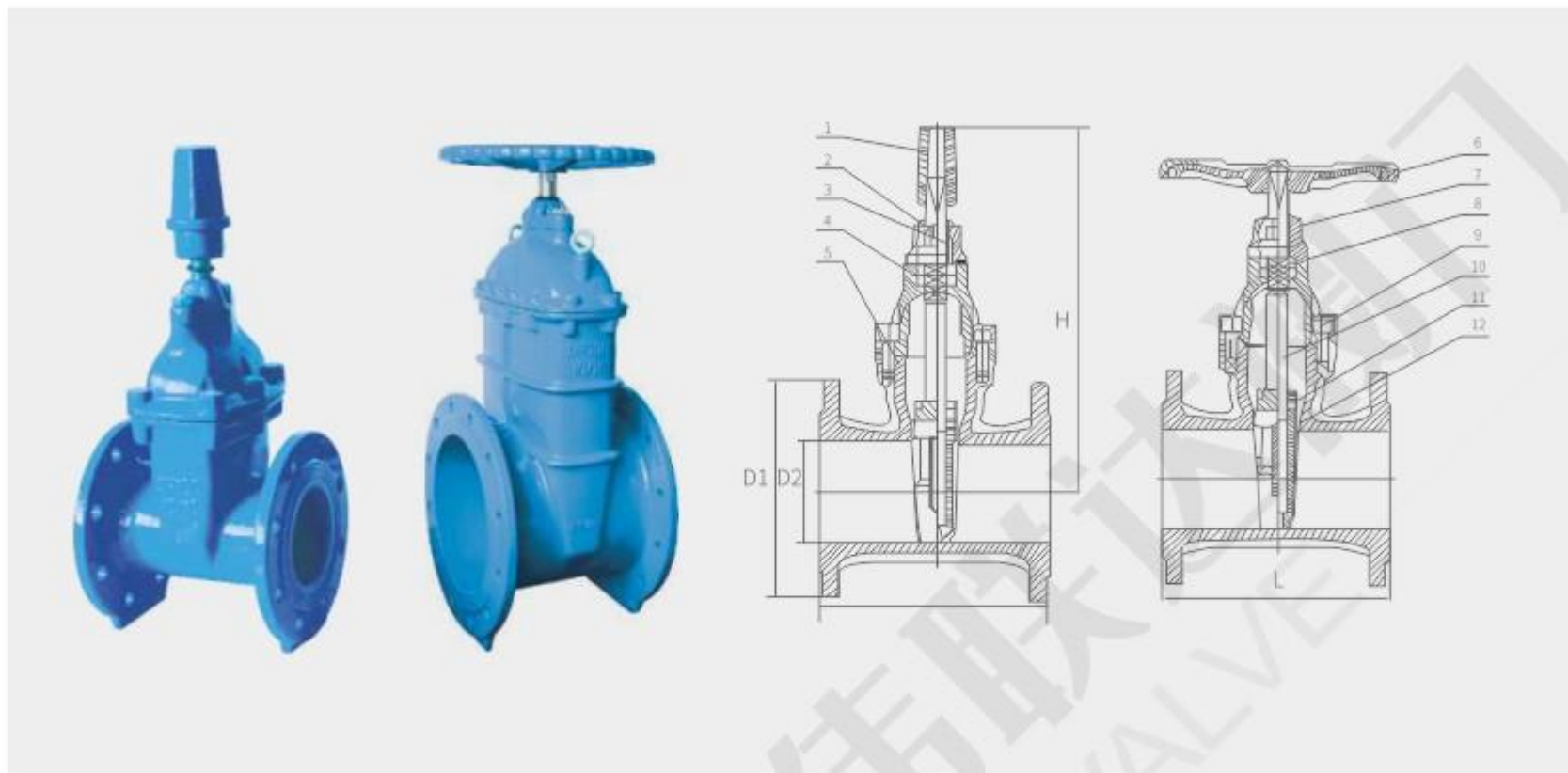

工作原理 Working principle

暗杆弹性座封闸阀又叫升降板闸阀。在升降闸板与阀杆上有螺母,通过阀门顶端与闸板上的螺母以及阀体上的导槽,将旋转运动变为直线运动,也就是将操作转矩变为操作推力。开启阀门时,当闸板提升高度等于门铜镜的1:1倍时,流体的通道完全畅通。

Non rising stem elastic seat sealing gate valve, also known as lifting plate gate valve. There are nuts on the lifting gate and valve stem, which convert rotary motion into linear motion through the nuts on the top of the valve and gate, as well as the guide groove on the valve body, that is, convert operating torque into operating thrust. When opening the valve, when the lifting height of the gate is equal to 1:1 times that of the door copper mirror, the fluid passage is completely unobstructed.

主要材料 Main materials

NO.	零件名称 Part Name	材质 Texture of material
1	传动帽 Transmission cap	球墨铸铁 Ductile iron
2	防尘帽 Dust cap	球墨铸铁 Ductile iron
3	O型圈 O-ring	NBR NBR
4	阀盖 Valve cover	球墨铸铁 Ductile iron
5	阀体 valve body	球墨铸铁 Ductile iron
6	手轮 handwheel	球墨铸铁 Ductile iron
7	轴盖 Shaft cover	球墨铸铁 Ductile iron
8	止推轴承 Thrust bearing	黄铜、青铜 Brass, bronze
9	螺栓 Bolt	35 thirty-five
10	阀杆 Valve stem	20Cr13 20Cr13
11	螺母 Screw nut	黄铜、青铜 Brass, bronze
12	阀瓣 Valve disc	球墨铸铁+EPDM/NBR Ductile iron+EPDM/NBR

主要连接尺寸 Main connection dimensions

DN	50	65	80	100	125	150	200	250	300	350	400	450	500
L GB	178	190	203	229	254	267	292	330	356	381	432	432	457
L F4	150	170	180	190	200	210	230	250	270	290	310	330	350
L F5	250	270	280	300	325	350	400	450	500	550	600	650	700
H	236	238	270	320	378	415	518	620	730	780	930	985	1180
Do	200	200	220	240	240	280	320	380	420	460	520	520	600

单位: mm

产品特点 Product Features

- 功能:可广泛用于自来水、污水、建筑、石油、化工、食品、医药、轻纺、电力、传播、冶金、能源系统等流体管线上作为调节合截流装置使用。
- 特点:Z45X弹性座封闸阀有灵敏、可靠、安装方便等特点。
- Function: It can be widely used as a regulating and intercepting device in fluid pipelines such as tap water, sewage, construction, petroleum, chemical, food, medicine, light textile, power, communication, metallurgy, energy systems, etc.
- Features: The Z45X elastic seat sealed gate valve has the characteristics of sensitivity, reliability, and easy installation.

技术参数 Technical Parameter

公称压力Nominal pressure:1.0~2.5MPa
公称通径Nominal diameter:50~600mm
工作温度Working temperature:0~120°C
适用介质:水、油、气等
Applicable media: water, oil, gas, etc
法兰标准 Flange standard:GB/T 17241.6 GB9113
试验标准 Test standard:GB13927 API598

Z41X(RRHX)明杆弹性座封闸阀 Z41X (RRHX) Rising stem elastic seat sealing gate valve

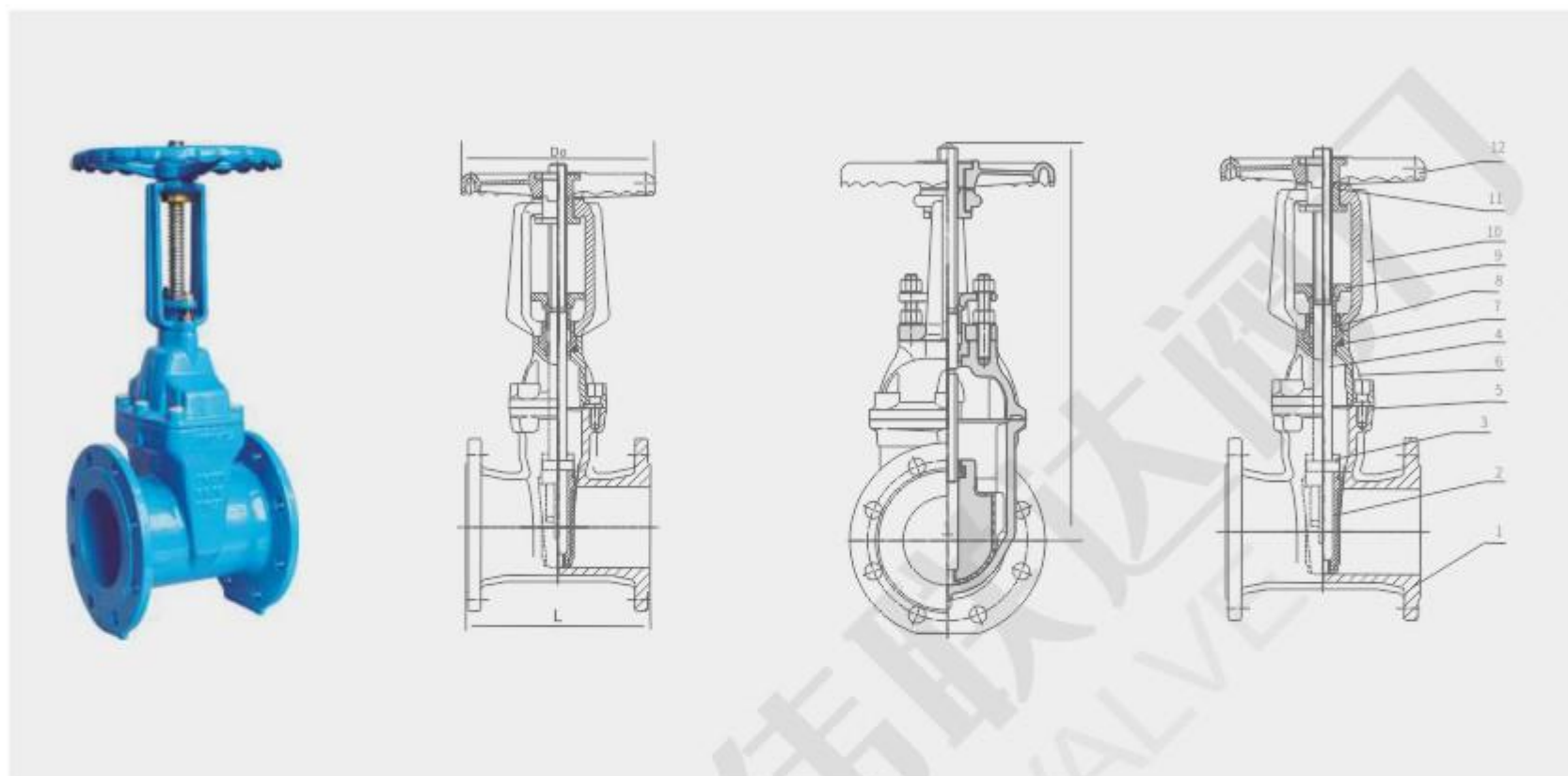

工作原理 Working principle

明杆弹性座封闸阀又叫升降杆闸阀。通常在升降杆上有梯形螺纹,通过阀门顶端的螺母以及阀体上的导槽,将旋转运动变为直线运动,也就是将操作转矩变为操作推力。开启阀门时,当闸板提升高度等于阀门铜镜的1倍时,流体的通道完全畅通。

The elastic seat sealing gate valve with a rising stem is also known as the lifting stem gate valve. Usually, there is a trapezoidal thread on the lifting rod, which transforms the rotating motion into linear motion through the nut at the top of the valve and the guide groove on the valve body, which is also known as turning the operating torque into the operating thrust. When opening the valve, when the height of the gate is equal to one time the height of the valve copper mirror, the fluid passage is completely unobstructed.

主要材料 Main materials

NO.	零件名称	Part Name	材质	Texture of material
1	阀体	Valve body	球墨铸铁	Ductile iron
2	阀瓣	Valve disc	球墨铸铁+EPDM/NBR	Ductile iron+EPDM/NBR
3	螺母	Nut	黄铜	Brass
4	阀杆	Valve stem	20Cr13	20Cr13
5	螺栓	Bolt	35	Thirty-five
6	阀盖	Valve cover	球墨铸铁	Ductile iron
7	铜套	Copper sleeve	黄铜	Brass
8	密封圈	Seal ring	NBR	NBR
9	压盖	Gland	WCB	WCB
10	支架	Bracket	球墨铸铁	Ductile iron
11	阀杆螺母	Stem Nut	黄铜	Brass
12	手轮	Handwheel	球墨铸铁	Ductile iron

产品特点

- 关闭严密可靠。采用牢固的橡胶密封环密封,利用液压控制原理,使滑盘关闭力与进水压力成正比,密封可靠性高。
- 过流量大。阀体采用全通道流线型设计,流体阻力小,流量大。
- 使用维护方便。主阀安装在水池外面,调试检查方便,维修简单。
- Close tightly and reliably. Adopting a sturdy rubber sealing ring for sealing, utilizing hydraulic control principles, the closing force of the sliding disc is proportional to the inlet pressure, resulting in high sealing reliability.
- Excessive flow. The valve body adopts full channel streamline design, with small fluid resistance and large flow.
- Easy to use and maintain. The main valve is installed outside the water tank, making debugging and inspection convenient and maintenance simple.

技术参数 Technical Parameter

公称压力Nominal pressure:1.0~2.5MPa
公称通径Nominal diameter:50~600mm
工作温度Working temperature:0~120°C
适用介质:水、油、气等
Applicable media: water, oil, gas, etc
法兰标准Flange standard:GB/T 17241.6
GB9113
试验标准Test standard:GB13927 API598

主要连接尺寸 Main connection dimensions

单位: mm

DN	50	65	80	100	125	150	200	250	300	350	400
L GB	178	190	203	229	254	267	292	330	356	381	432
L F4	150	170	180	190	200	210	230	250	270	290	310
L F5	250	270	280	300	325	350	400	450	500	550	600
H	230	239	272	314	372	419	510	639	725	757	937
Do	200	200	220	240	240	280	320	380	420	460	520

Z945X(RVEX)电动弹性座封闸阀
Z945X (RVEX) electric elastic seat seal gate valve

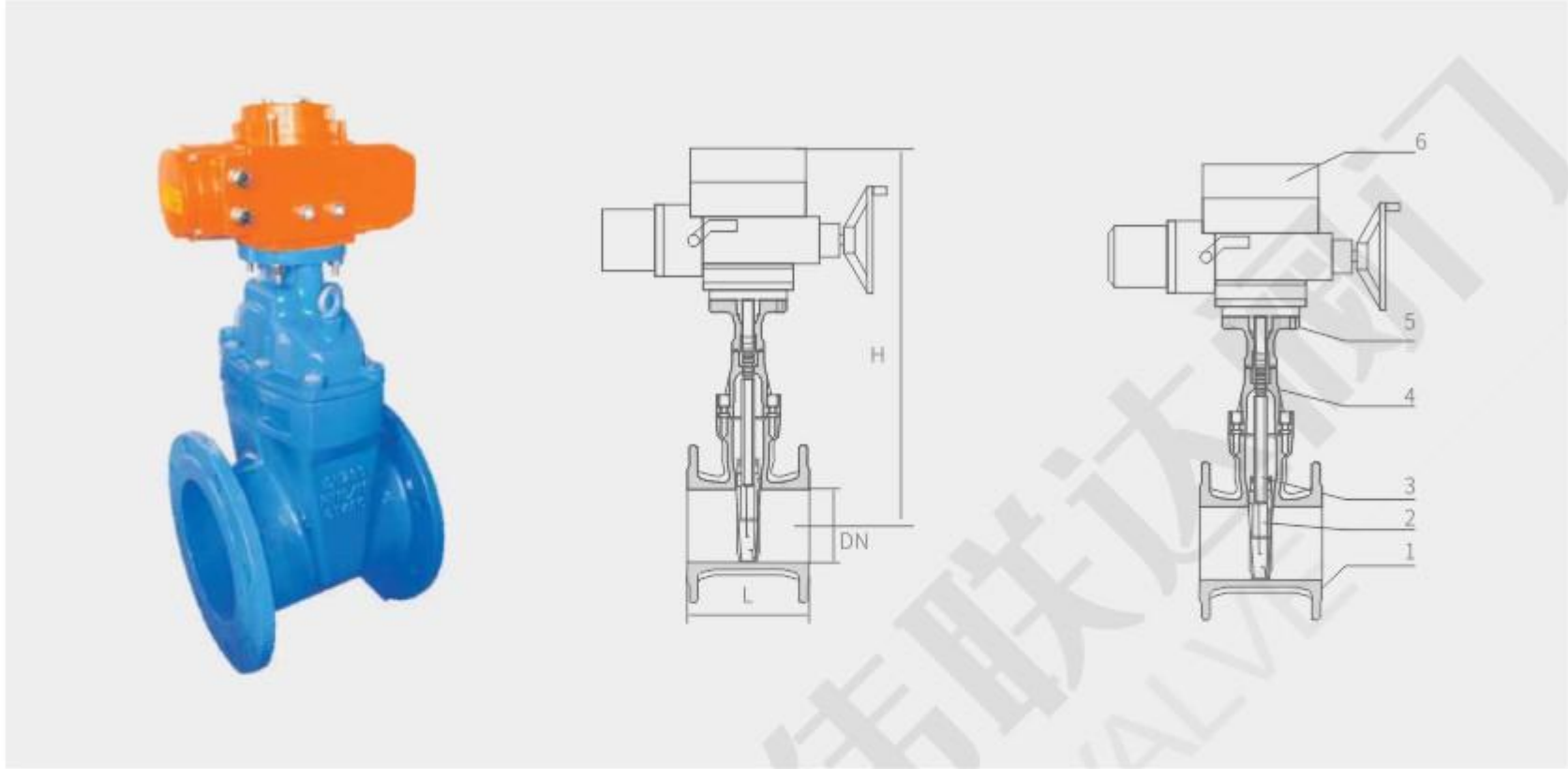

工作原理 Working principle

电动暗杆弹性座封闸阀又叫升降板闸阀。在升降闸板与阀杆上有螺母,通过阀门顶端与闸板上的螺母以及阀体上的导槽,将旋转运动变为直线运动,也就是将操作转矩变为操作推力。开启阀门时,当闸板提升高度等于阀门铜镜1:1倍时,流体的通道完全畅通。

Electric non rising stem elastic seat sealing gate valve, also known as lifting plate gate valve. There are nuts on the lifting gate and valve stem, which convert rotary motion into linear motion through the nuts on the top of the valve and gate, as well as the guide groove on the valve body, that is, convert operating torque into operating thrust. When opening the valve, when the lifting height of the gate is 1:1 times that of the valve copper mirror, the fluid passage is completely unobstructed.

主要材料 Main materials

NO.	零件名称 Part Name	材质 Texture of material
1	阀体 valve body	球墨铸铁、铸钢 Ductile iron, cast steel
2	闸板 Ram	球墨铸铁+EPDM/NBR Ductile iron+epdm/nbr
3	阀杆 Valve stem	20Cr13 20cr13
4	阀盖 Valve cover	球墨铸铁、铸钢 Ductile iron, cast steel
5	支架 Bracket	球墨铸铁、铸钢 Ductile iron, cast steel
6	电动头 Electric actuator	

主要连接尺寸 Main connection dimensions

DN	50	65	80	100	125	150	200	250	300	350	400	450	500
L GB	178	190	203	229	254	267	292	330	356	381	432	432	457
L F4	150	170	180	190	200	210	230	250	270	290	310	330	350
L F5	250	270	280	300	325	350	400	450	500	550	600	650	700
H	236	238	270	320	378	415	518	620	730	780	930	985	1180
H1	282	282	282	282	282	267	267	267	267	267	415	415	415

单位: mm

产品特点 Product Features

- 功能:可广泛用于自来水、污水、建筑、石油、化工、食品、医药、轻纺、电力、传播、冶金、能源系统等流体管线上作为调节合截流装置使用。
- 特点:Z45X弹性座封闸阀有灵敏、可靠、安装方便等特点。
- Function: It can be widely used as a regulating and intercepting device in fluid pipelines such as tap water, sewage, construction, petroleum, chemical, food, medicine, light textile, power, communication, metallurgy, energy systems, etc.
- Features: The Z45X elastic seat sealed gate valve has the characteristics of sensitivity, reliability, and easy installation.

技术参数 Technical Parameter

公称压力Nominal pressure:1.0~2.5MPa
公称通径Nominal diameter:50~600mm
工作温度Working temperature:0~120°C
适用介质:水、油、气等
Applicable media: water, oil, gas, etc
法兰标准Flange standard:GB/T 17241.6 GB9113
试验标准Test standard:GB13927 API598

消防明杆闸阀 Fire rising stem gate valve

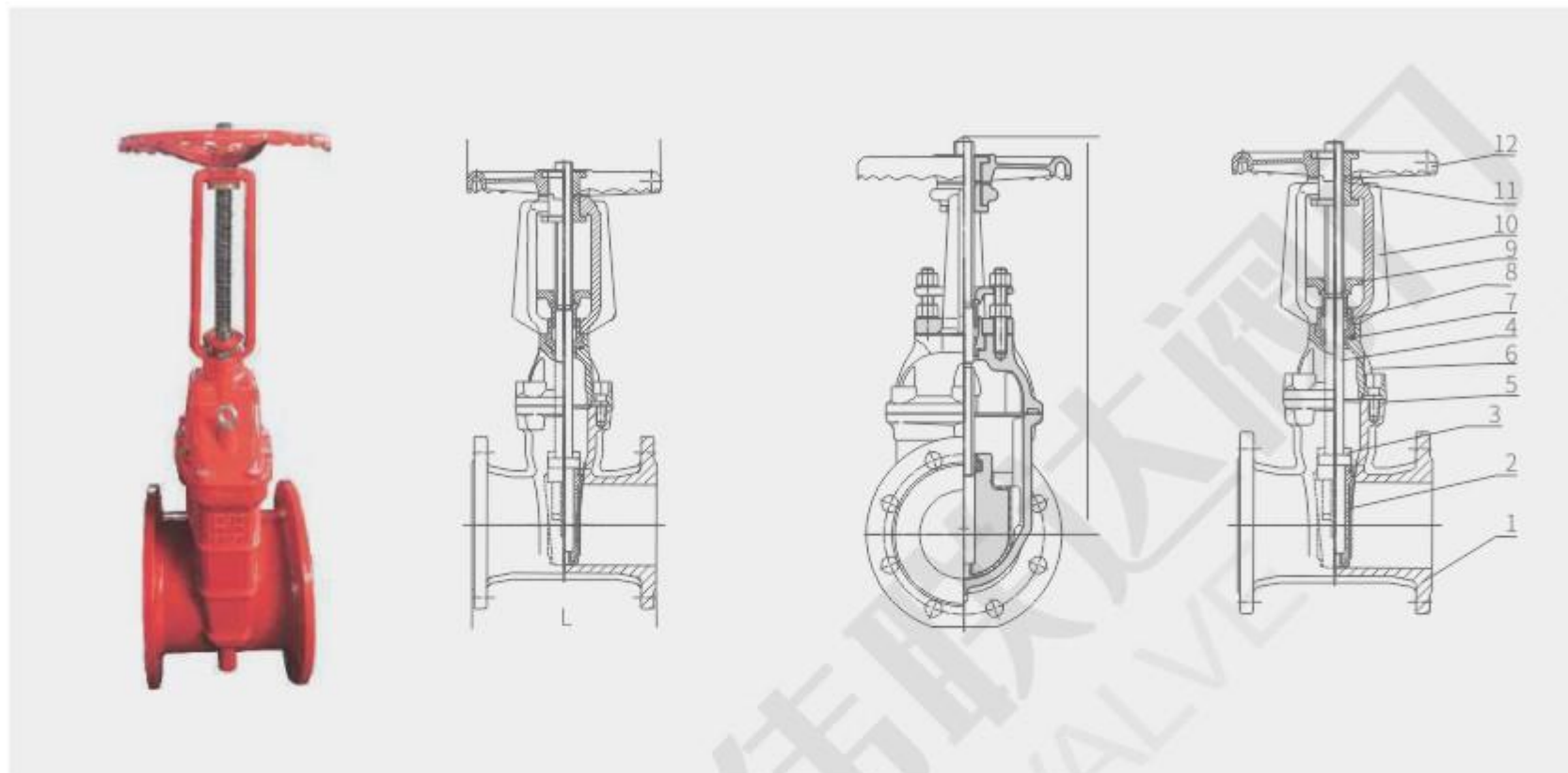

工作原理 Working principle

消防明杆弹性座封闸阀又叫升降杆闸阀。通常在升降杆上有梯形螺纹,通过阀门顶端的螺母以及阀体上的导槽,将旋转运动变为直线运动,也就是将操作转矩变为操作推力。开启阀门时,当闸板提升高度等于阀门铜镜的1:1倍时,流体的通道完全畅通。

Fire protection rising stem elastic seat sealing gate valve, also known as lifting stem gate valve. Usually, there is a trapezoidal thread on the lifting rod, which transforms the rotating motion into linear motion through the nut at the top of the valve and the guide groove on the valve body, that is, the operating torque is converted into the operating thrust. When opening the valve, when the lifting height of the gate is equal to 1:1 times the copper mirror of the valve, the fluid passage is completely unobstructed.

主要材料 Main materials

NO.	零件名称	Part Name	材质	Texture of material
1	阀体	Valve body	球墨铸铁	Ductile iron
2	阀瓣	Valve disc	球墨铸铁+EPDM/NBR	Ductile iron+EPDM/NBR
3	螺母	Nut	黄铜	Brass
4	阀杆	Valve stem	20Cr13	20Cr13
5	螺栓	Bolt	35	Thirty-five
6	阀盖	Valve cover	球墨铸铁	Ductile iron
7	铜套	Copper sleeve	黄铜	Brass
8	密封圈	Seal ring	NBR	NBR
9	压盖	Gland	WCB	WCB
10	支架	Bracket	球墨铸铁	Ductile iron
11	阀杆螺母	Stem Nut	黄铜	Brass
12	手轮	Handwheel	球墨铸铁	Ductile iron

产品特点

- 关闭严密可靠。采用牢固的橡胶密封环密封,利用液压控制原理,使滑盘关闭力与进水压力成正比,密封可靠性高。
- 过流量大。阀体采用全通道流线型设计,流体阻力小,流量大。
- 使用维护方便。主阀安装在水池外面,调试检查方便,维修简单。
- Close tightly and reliably. Adopting a sturdy rubber sealing ring for sealing, utilizing hydraulic control principles, the closing force of the sliding disc is proportional to the inlet pressure, resulting in high sealing reliability.
- Excessive flow. The valve body adopts full channel streamline design, with small fluid resistance and large flow.
- Easy to use and maintain. The main valve is installed outside the water tank, making debugging and inspection convenient and maintenance simple.

技术参数 Technical Parameter

公称压力Nominal pressure:1.0~2.5MPa
公称通径Nominal diameter:50~600mm
工作温度Working temperature:0~120°C
适用介质:水、油、气等
Applicable media: water, oil, gas, etc
法兰标准Flange standard:GB/T 17241.6
GB9113
试验标准Test standard:GB13927 API598

主要连接尺寸 Main connection dimensions

单位: mm

DN	50	65	80	100	125	150	200	250	300	350	400
L GB	178	190	203	229	254	267	292	330	356	381	432
L F4	150	170	180	190	200	210	230	250	270	290	310
L F5	250	270	280	300	325	350	400	450	500	550	600
H	230	239	272	314	372	419	510	639	725	757	937
Do	200	200	220	240	240	280	320	380	420	460	520

大口径弹性座封闸阀

Large caliber elastic seat sealing gate valve

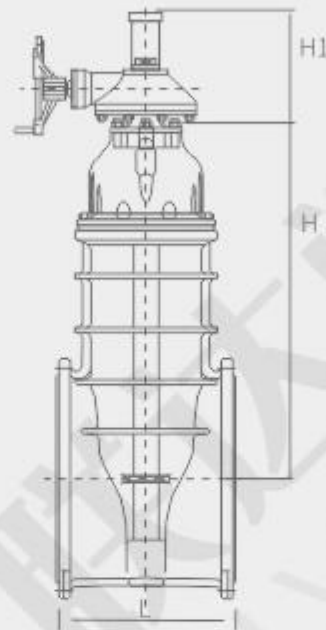

工作原理

暗杆弹性座封闸阀又叫升降板闸阀。在升降闸板与阀杆上有螺母,通过阀门顶端与闸板上的螺母以及阀体上的导槽,将旋转运动变为直线运动,也就是将操作转矩变为操作推力。开启阀门时,当闸板提升高度等于阀门铜镜1:1倍时,流体的通道完全畅通。

Non rising stem elastic seat sealing gate valve, also known as lifting plate gate valve. There are nuts on the lifting gate and valve stem, which convert rotary motion into linear motion through the nuts on the top of the valve and gate, as well as the guide groove on the valve body, that is, convert operating torque into operating thrust. When opening the valve, when the lifting height of the gate is 1:1 times that of the valve copper mirror, the fluid passage is completely unobstructed.

主要材料 Main materials

NO.	零件名称 Part Name	材质 Texture of material
1	阀体 Valve body	球墨铸铁 Ductile iron
2	阀瓣 Valve disc	球墨铸铁+EPDM/NBR Ductile iron+EPDM/NBR
3	螺母 Nut	黄铜 Brass
4	阀杆 Valve stem	20Cr13
5	螺栓 Bolt	35
6	阀盖 Valve cover	球墨铸铁 Ductile iron
7	铜套 Copper sleeve	黄铜 Brass
8	密封圈 Seal ring	NBR
9	压盖 Gland	WCB
10	支架 Bracket	球墨铸铁 Ductile iron
11	阀杆螺母 Stem Nut	黄铜 Brass
12	手轮 Handwheel	球墨铸铁 Ductile iron

主要连接尺寸

DN		500	600	700	800	900	1000	1200	1400
L	GB	457	508	610	660	711	811	960	1080
L	F4	350	390	430	470	510	550	630	710
L	F5	700	800	900	1000	1100	1200	1400	/
H	Bearing	1048	1208	1390	1594	1594	1860	2270	2620
H1	Spur Gear	350	350	360	360	360	425	425	/

单位: mm

产品特点

大口径弹性座封闸阀采用最优质得球墨铸铁或碳钢铸造而成,具有强度高、重量轻,几何尺寸精确的特点,闸板具有互换的功能,加装螺旋伞齿轮省力结构,一人可非常轻松自如地开关,也可根据用户的要求加装开闭指示柱,或电动、气动执行机构。密封、防锈功能极佳、安全可靠,使用寿命长。可立式卧式安装,此大口径弹性座封闸阀广泛用于给排水系统、污水处理系统、市政建设及矿山、冶金、电厂等行业。

The large-diameter elastic seat sealing gate valve is made of the highest quality ductile iron or carbon steel casting, which has the characteristics of high strength, light weight, and precise geometric dimensions. The gate plate has the function of interchangeability, and is equipped with a spiral bevel gear labor-saving structure. One person can easily open and close it. It can also be equipped with an open/close indicator column or an electric or pneumatic actuator according to user requirements. Excellent sealing and rust prevention functions, safe and reliable, and long service life. This large-diameter elastic seat sealing gate valve can be installed vertically and horizontally, and is widely used in water supply and drainage systems, sewage treatment systems, municipal construction, mining, metallurgy, power plants and other industries.

技术参数 Technical Parameter

公称压力Nominal pressure:1.0~2.5MPa
公称通径Nominal diameter:500~1400mm
工作温度Working temperature:0~120°C
适用介质:水、油、气等
Applicable media: water, oil, gas, etc
法兰标准Flange standard:GB/T 17241.6 GB9113
试验标准Test standard:GB13927 API598

H44X(SFCV)橡胶瓣止回阀 H44X (SFCV) rubber disc check valve



1.阀体 2.O型密封圈 3.阀盖 4.阀瓣 5.螺栓

工作原理 Working principle

当介质按规定方向流动时,阀瓣受介质力的作用,被开启;介质逆流时,依靠介质本身流动自行快速关闭,达到阻止介质逆流的目的。

When the medium flows in the specified direction, the valve disc is opened under the action of the medium force; When the medium is in reverse flow. Relying on the flow of the medium itself to quickly shut down, achieving the goal of preventing reverse flow of the medium.

产品特点 Product Features

功能:依靠介质本身流动而自动开、闭阀瓣,用来防止介质倒流。

应用区域:石油、化工、冶金、水处理等。

Function: Automatically open and close the valve disc by relying on the flow of the medium itself, to prevent medium backflow.

Application areas: petroleum, chemical industry, metallurgy, water treatment, etc.

特点:

- 低压启闭性能好
- 水头损失小
- 阀瓣整体包胶,保证不受污染
- 使用寿命长

Characteristic:

- Good low-voltage opening and closing performance
- Low head loss
- The overall sealing of the valve disc ensures that it is not contaminated
- Long service life

主要材料 Main materials

NO.	零件名称	Part Name	材质	Texture of material
1	阀体	Valve body	球墨铸铁、铸钢	Ductile iron, cast steel
2	O型密封圈	O-ring seal	NBR	NBR
3	阀盖	Valve cover	球墨铸铁、铸钢	Ductile iron, cast steel
4	阀瓣	Valve disc	球墨铸铁、铸钢	Ductile iron, cast steel

技术参数 Technical Parameter

公称通径Nominal diameter:DN50~DN600
工作压力Working pressure:1.0MPa,1.6MPa, 2.5MPa
介质温度Medium temperature:0~80°C
适用介质:水
Applicable medium: water
测试标准Test standard:GB/T13927-2008

典型应用 Typical Applications

- 水厂及水源工程
Water plant and water source engineering
- 环境保护
Environmental protection
- 市政设施
Municipal facilities
- 电力及共用事业
Electricity and utilities
- 建筑行业
Construction industry
- 石油、化工
Petroleum and chemical industry
- 钢铁、冶金
Steel, metallurgy
- 造纸行业
Paper industry

主要连接尺寸 Main connection dimensions

单位:mm

DN	50	65	80	100	125	150	200	250	300	350	400	450	500	600
L	203	216	241	292	330	356	495	622	698	787	914	965	1067	1219
H														

HC41X消声止回阀
HC41X silencing check valve

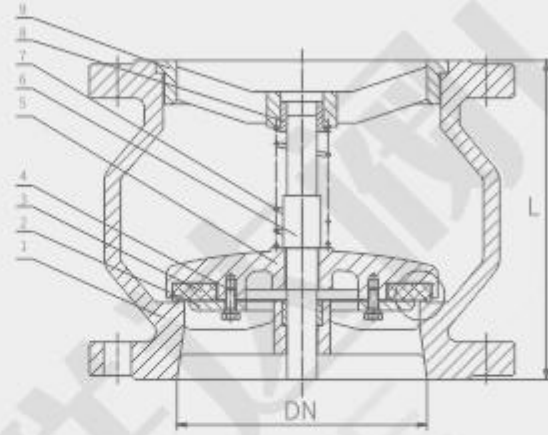

工作原理 Working principle

当介质按规定方向流动时,阀瓣受介质力的作用被顶开,实现开启;介质逆流时,因阀瓣背面弹簧力和介质反向力的作用,使阀瓣与阀座的密封面紧密贴合而关闭,由于阀瓣密封面采用橡胶密封,从而实现消声和阻止介质逆流的目的。

When the medium flows in the specified direction, the valve disc is pushed open by the force of the medium, achieving opening; When the medium is in reverse flow, due to the spring force on the back of the valve disc and the reverse force of the medium, the sealing surface of the valve disc and the valve seat tightly fit and close. As the sealing surface of the valve disc is sealed with rubber, the purpose of noise reduction and preventing the medium from reverse flow is achieved.

主要材料 Main materials

NO.	零件名称 Part name	材质 Texture of material
1	阀体 Valve body	球墨铸铁、铸钢、不锈钢 Ductile iron, cast steel, stainless steel
2	压板 Pressing plate	不锈钢 Stainless steel
3	密封垫 A seal	NBR NBR
4	螺栓 Bolt	不锈钢 Stainless steel
5	阀瓣 Valve disc	球墨铸铁、铸钢、不锈钢 Ductile iron, cast steel, stainless steel
6	阀杆 Valve stem	不锈钢 Stainless steel
7	弹簧 Spring	不锈钢 Stainless steel
8	导向套 Guide sleeve	铜合金 Copper alloy
9	支架 Bracket	球墨铸铁、铸钢、不锈钢 Ductile iron, cast steel, stainless steel

产品特点

消声止回阀是指依靠介质本身流动而自动开、闭阀瓣,用来防止介质倒流的阀门,又称逆止阀、单向阀、逆流阀。该阀门适用于给排水系统、高层建筑管网,广泛应用于泵出口的管道上。

Silencing check valve refers to a valve that automatically opens and closes the valve disc based on the flow of the medium itself to prevent medium backflow, also known as a check valve, one-way valve, or backflow valve. This valve is suitable for water supply and drainage systems, high-rise building pipe networks, and is widely used in pump outlet pipelines.

- ◇可以水平或垂直安装
- ◇水头损失小
- ◇噪音小、结构紧凑、密封可靠
- ◇强度高
- ◇有效防止水锤
- ◇长导向轴可以有效防止阀瓣位移
- ◇独特的法兰切口可以放置经过的电缆线(DN100及以下)

Can be installed horizontally or vertically
Low head loss
Low noise, compact structure, and reliable sealing
High strength
Effectively preventing water hammer
Long guide shaft can effectively prevent valve disc displacement
Unique flange cut allows for the placement of cables passing through (DN100 and below)

技术参数 Technical Parameter

公称口径Nominal diameter:DN50~DN600
工作压力Working pressure:1.0MPa,1.6MPa,2.5MPa
介质温度Medium temperature:0~80°C
适用介质Applicable medium:水
测试标准Test standard:GB/T139272008

主要连接尺寸 Main connection dimensions

单位:mm

DN	50	65	80	100	125	150	200	250	300	350	400	450	500	600
L	120	130	150	165	190	210	255	310	320	380	405	430	450	510
H														

CL41H-Y型过滤器 CL41H-Y filter



工作原理 Working principle

Y型过滤器是输送介质的管道系统不可缺少的一种过滤装置,Y型过滤器通常安装在减压阀、泄压阀、定水位阀或其它设备的进口端,用来清除介质中的杂质,以保护阀门及设备的正常使用。当液体通过主管进入滤篮后,固体杂质颗粒被阻挡在滤篮内,而洁净的流体通过滤篮、由过滤器出口排出。

Y-type filters are an indispensable filtering device in pipeline systems for conveying media. Y-type filters are usually installed at the inlet of pressure reducing valves, relief valves, constant water level valves, or other equipment to remove impurities from the media and ensure the normal use of valves and equipment. When the liquid enters the filter blue through the main pipe, solid impurity particles are blocked in the filter blue, and clean fluid is discharged through the filter blue and the filter outlet.

产品特点 Product Features

- Y型过滤器具有结构先进,阻力小,排污方便等特点
- Y型过滤器适用介质可为水、油、气
- 一般通水网为18~30目,通气网为10~100目,通油网为100~480目
- 篮式过滤器主要由接管、主管、滤篮、法兰、法兰盖及紧固件等组成
- The Y-type filter has the characteristics of advanced structure, low resistance, and convenient discharge
- The suitable media for Y-type filters can be water, oil, and gas
- Generally, the water network is 18-30 mesh, the ventilation network is 10-100 mesh, and the oil network is 100-480 mesh
- The basket filter mainly consists of connecting pipes, main pipes, filter baskets, flanges, flange covers, and fasteners

主要材料 Main materials

NO.	零件名称	Part name	材质	Texture of material
1	阀体	Valve body	球墨铸铁、铸钢	Ductile iron, cast steel
2	阀盖	Valve cover	球墨铸铁、铸钢	Ductile iron, cast steel
3	膜片	Diaphragm	压板 球墨铸铁、铸钢	Pressure plate ductile iron, cast steel
4	阀盘	Valve disc	球墨铸铁、铸钢	Ductile iron, cast steel
5	阀杆	Valve stem	不锈钢	Stainless steel
6	膜片	Diaphragm	NBR	NBR

主要连接尺寸 Main connection dimensions

	65	80	100	125	150	200	250	300
DN	65	80	100	125	150	200	250	300
L	290	310	350	400	480	600	730	850
H	178	200	225	264	312	395	482	565

单位:mm

技术参数 Technical Parameter

公称通径Nominal diameter:DN65~DN800
工作压力Working pressure:1.0MPa,1.6MPa,2.5MPa
介质温度Medium temperature:0~80°C
适用介质:水
Applicable medium: water
测试标准Test standard:GB/T13927-2008

典型应用 Typical Applications

- 水厂及水源工程
Water plant and water source engineering
- 环境保护
Environmental protection
- 市政设施
Municipal facilities
- 电力及共用事业
Electricity and utilities
- 建筑行业
Construction industry
- 石油、化工
Petroleum and chemical industry
- 钢铁、冶金
Steel, metallurgy
- 造纸行业
Paper industry

KXT型可曲挠单球橡胶接头
KXT type flexible single ball rubber joint

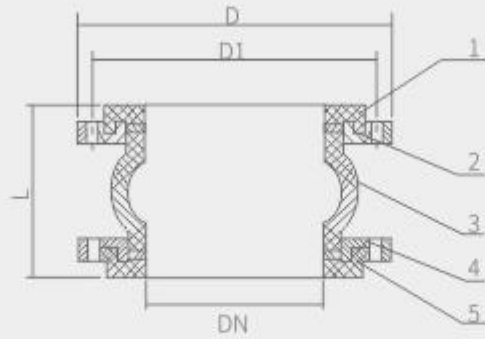

主要材料 Main materials

序号 No.	名称 Name	材料 Material
1	外胶层 Outer adhesive layer	11R、CR、EPDM、NR、NBR
2	内胶层 Inner adhesive layer	11R、CR、EPDM、NR、NBR
3	骨架层 Skeleton layer	聚酯帘布 Polyester cord
4	法兰 flange	Q235 304 316L
5	增强圈 Enhancement circle	钢丝圈 Steel wire ring

产品说明 Product explain

法兰可做碳钢及多种不锈钢材质,球体可做丁腈橡胶、三元乙丙、氯丁橡胶等材质。
法兰连接采用GB/T9115-2000B标准。

The flange can be made of carbon steel and various stainless steel materials, and the sphere can be made of Nitrile rubber, EPDM, Neoprene and other materials. The flange connection adopts the GB/T9115-2000B standard.

设计参数表 Design parameter table

公称通径 DNmm Nominal Diameter	长度L mm Length	螺丝数 n Number of screws	螺栓孔 直径mm Bolt hole diameter	螺栓孔中心 圆直径mm Bolt hole center circle diameter	轴向位移mm Axial displacement		横向位移 mm Lateral Displacement	偏转角度 ($\alpha_1+\alpha_2$) Deflection angle
					伸长 Elongate	压缩 Compress		
32	95	4	18	100	6	9	9	15
40	95	4	18	110	6	10	9	15
50	105	4	18	125	7	10	10	15
65	115	4	18	145	4	13	11	15
80	135	4	18	160	8	15	12	15
100	150	8	18	180	10	19	13	15
125	165	8	18	210	12	19	13	15
150	175	8	23	240	12	20	14	15
250	230	12	23	350	16	25	22	15
300	245	12	23	400	16	25	22	15
350	255	16	23	460	16	25	22	15
400	255	16	25	515	16	25	22	15
450	255	20	25	565	16	25	22	15
500	255	20	25	620	6	25	22	15
600	260	20	30	725	6	25	22	15
700	260	24	30	840	16	25	22	15
800	260	24	34	950	16	25	22	15
900	260	28	34	1050	6	25	22	15
1000	260	28	34	1160	18	26	24	15
1200	300	32	41	1380	18	26	24	15
1400	350	36	34	1560	20	28	26	15
1600	350	40	34	1760	25	28	30	10
1800	400	44	41	1970	25	30	30	10
2000	450	48	48	2180	25	30	30	10
2200	500	52	43	2390	25	35	30	10
2400	500	56	43	2600	25	35	30	10
2600	550	60	48	2810	25	35	30	10
2800	550	64	48	3020	25	35	30	10
3000	550	68	48	3220	25	35	30	10
3200	600	72	36	3430	25	35	30	10

TB型通用波纹补偿器 TB type universal ripple compensator

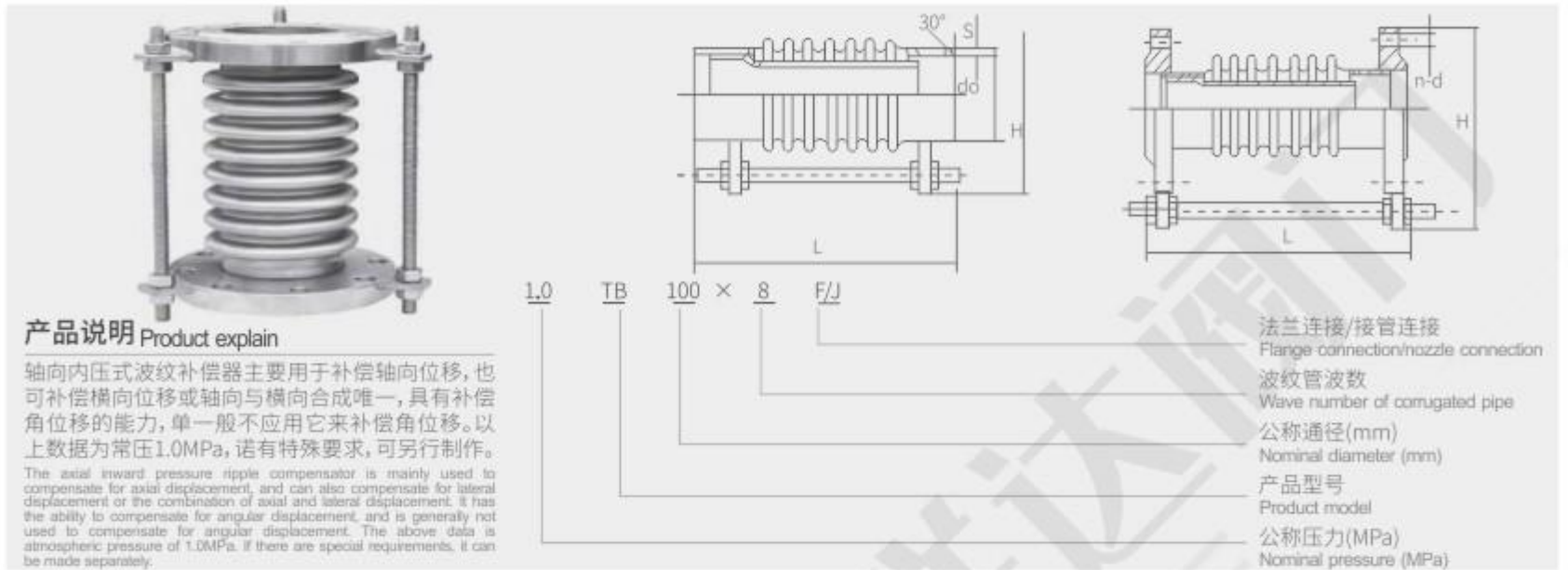

安装数据表 Installation data sheet

公称通径DN (mm) Nominal Diameter	产品型号 Model	计算疲劳破坏次数 下轴向外补偿器XO(mm) Calculating the number of fatigue failures with axial outward compensator			补偿器 Compensator		刚度 Stiffness			径向最大有效面积 Acm ²	接管端口外形尺寸 H(mm)	Do×S(mm)		总长L(mm) Total length		总重W(kg) Total weight	
		1500	1300	1500	横向Yo Horizontal Yo	角向Y Angular orientation	轴向 Axial	横向 Transverse	角向 Angular orientation			法兰连接 Flange connection	法兰 Flange	接管 By tube	法兰 Flange	接管 By tube	
80	1.0YSTA80×8J/F	30	25	18	6.4	±6.4	358	418	8.4	81	284	Φ890×4	244	344	10	3	
	1.0STA80×10J/F	37	32	22	10	±8	286	214	6.7	81	284	Φ890×4	274	374	10	3	
100	1.0YSTA100×6J/F	33	28	20	3.6	±3.6	417	1471	14	121	304	Φ108×4	223	323	11	3	
	1.0YSTA100×10J/F	56	47	33	10	±8	250	318	8.5	121	304	Φ108×4	287	387	13	5	
125	1.0YSTA125×5J/F	36	32	21	2.5	±4.4	408	2885	21	180	334	Φ133×4	216	318	13	4	
	1.0YSTA125×8J/F	65	58	38	8	±8	227	495	12	180	334	Φ133×4	288	388	14	5	
150	1.0YSTA150×5J/F	48	41	27	2.5	±5	300	2889	20	257	364	Φ159×4.5	238	338	17	7	
	1.0YSTA150×8J/F	77	65	43	6.4	±8	188	705	23	257	364	Φ159×4.5	295	398	18	8	
200	1.0YSTA200×4J/F	56	47	31	3.2	±5.3	288	3164	39	479	442	Φ219×6	244	344	25	17	
	1.0YSTA200×6J/F	84	70	46	7.2	±8	192	9938	26	479	442	Φ219×6	298	340	27	20	
250	1.0YSTA250×4J/F	63	53	36	4.8	±5.3	588	4371	128	769	497	Φ273×8	309	409	38	22	
	1.0YSTA250×6J/F	95	80	53	10.8	±8	392	1295	85	769	497	Φ273×8	387	487	43	27	
300	1.0YSTA300×4J/F	65	54	37	6.4	±5.3	830	4444	249	1105	547	Φ325×8	358	458	49	32	
	1.0YSTA300×6J/F	97	82	55	14	±5.8	553	1371	166	1105	547	Φ325×8	456	556	56	39	
350	1.0YSTA350×4J/F	72	60	40	6	±8	840	4289	309	1307	607	Φ377×10	499	487	73	40	
	1.0YSTA350×6J/F	107	90	61	14	±8	560	1431	206	1307	607	Φ377×10	387	599	82	55	
400	1.0YSTA400×4J/F	74	62	42	6	±5.3	918	6199	420	1611	685	Φ426×4	400	500	91	54	
	1.0YSTA400×6J/F	112	93	63	14	±7.8	612	7837	280	1611	685	Φ426×4	510	610	107	65	
450	1.0YSTA450×4J/F	82	69	46	4.8	±5.2	690	8210	379	1972	735	Φ478×10	389	489	111	68	
	1.0YSTA450×6J/F	124	103	68	10.8	±7.8	450	2433	253	1972	735	Φ478×10	489	589	121	78	
500	1.0YSTA500×4J/F	84	70	47	4.8	±4	1468	20515	1477	3534	920	Φ529×10	415	517	126	82	
	1.0YSTA500×6J/F	126	105	70	10.8	±6.9	485	2922	343	2445	790	Φ529×10	515	615	138	93	
600	1.0YSTA600×4J/F	86	72	48	4.8	±4	1468	20515	1477	3534	920	Φ630×10	458	558	167	127	
	1.0YSTA600×6J/F	129	108	72	10.8	±6	978	60786	985	3534	920	Φ630×10	658	758	181	141	
700	1.0YSTA700×2J/F	43	36	24	12	±1.7	3250	20989	4445	4717	1050	Φ720×10	346	446	267	160	
	1.0YSTA700×4J/F	85	72	48	4.8	±3.4	4625	26237	2222	4717	1050	Φ720×10	466	566	285	178	
800	1.0YSTA700×6J/F	128	107	72	108	±5.1	1083	58317	1482	4717	1050	Φ720×10	666	766	313	206	
	1.0YSTA800×2J/F	42	35	24	0.8	±1.5	3555	38260	6122	5822	1165	Φ820×10	354	454	385	18	
800	1.0YSTA800×4J/F	84	70	48	3.2	±3	1778	47826	3061	5822	1165	Φ820×10	474	576	403	234	
	1.0YSTA800×6J/F	168	141	96	12.8	±6	889	5678	1530	5822	1165	Φ820×10	594	694	456	286	

铜阀门系列

Copper valve series

黄铜锻压内牙球阀

Brass forged inner tooth ball valve

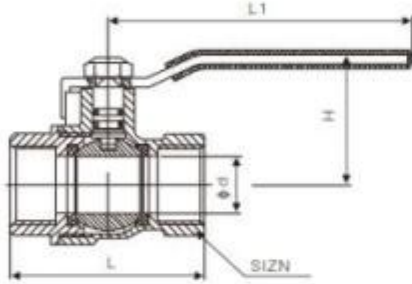

外形尺寸 Overall dimensions

单位: mm

DN	SIZE	L	d	H	Φd
15	1/2	41	52.5	97	14
20	3/4	44	63	97	19
25	1	55	72	110	24
32	1 1/4	60	77	140	29
40	1 1/2	65	87	140	35
50	2	74	102	155	45

主要技术参数

公称压力: 1.6MPa
适用介质: 水、非腐蚀性液体
工作温度: -10~100℃
螺纹符合: ISO228标准

Main technical parameters

Nominal pressure: 1.6MPa
Applicable medium: water, non corrosive liquid
Working temperature: -10~100 °C
Thread complies with ISO228 standard

黄铜截止阀

Brass globe valve

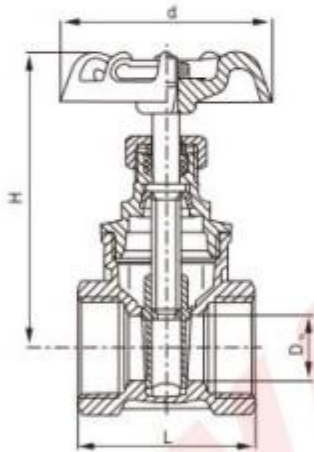

外形尺寸 Overall dimensions

单位: mm

DN	SIZE	L	d	H	D ₀
15	1/2	45	13	73	53
20	3/4	51	17	78	53
25	1	55	21	80	59
32	1 1/4	57	27	95	73
40	1 1/2	60	33	110	73
50	2	71	45	142	80
65	2 1/2	85	56	165	100

主要技术参数

公称压力: 1.6MPa
适用介质: 水、气、油
工作温度: ≤170℃

Main technical parameters

Nominal pressure: 1.6MPa
Applicable media: water, gas, oil
Working temperature: ≤ 170 °C

黄铜闸阀

Brass gate valve

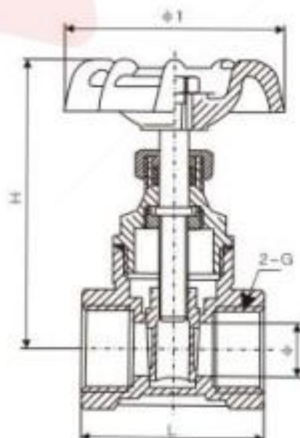

外形尺寸 Overall dimensions

单位: mm

DN	SIZE	L	d	H	D
15	1/2	65	45	12.5	54
20	3/4	71	51	16	54
25	1	82	64.5	22	72
32	1 1/4	95	75	26	72
40	1 1/2	110	82	32	100
50	2	123	100	41	110

主要技术参数

公称压力: 1.6MPa
工作介质: 水、非腐蚀性液体
工作温度: -20℃ ≤ T ≤ 120℃
管螺纹符合 ISO 228 标准

Main technical parameters

Nominal pressure: 1.6MPa
Working medium: water, non corrosive liquid
Working temperature: -20 °C ≤ T ≤ 120 °C
Pipe threads comply with ISO 228 standard

数字锁定平衡阀
Digital locking balance valve

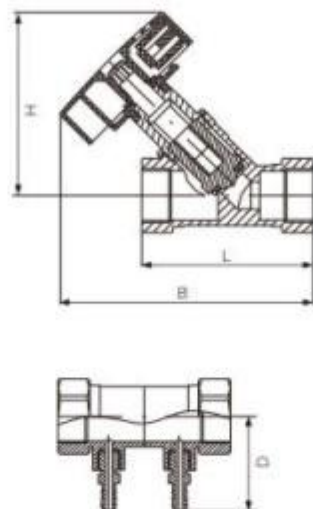

外形尺寸 Overall dimensions

单位: mm

DN	SIZE	H	L	B	Φd
15	1/2	95	75	105	47.5
20	3/4	95	75	110	47.5
25	1	95	92	110	50
32	1 1/4	108	110	128	60
40	1 1/2	112	120	140	68
50	2	128	128	160	68

主要技术参数

公称压力:1.6MPa
适用介质:水、非腐蚀性液体
工作温度:0°C≤T≤110°C
标准:管螺纹符合ISO228标准

Main technical parameters

Nominal pressure: 1.6MPa
Applicable medium: water, non corrosive liquid
Working temperature: 0 °C ≤ T ≤ 110 °C
Standard: Pipe threads comply with ISO228 standard

黄铜卧式止回阀
Brass horizontal check valve

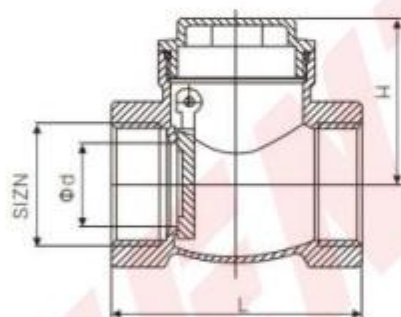

外形尺寸 Overall dimensions

单位: mm

DN	SIZE	L	B	H	D
15	1/2	51.5	14	44	86
20	3/4	58.5	19	47	86
25	1	68.5	24	53	106
32	1 1/4	80.5	31	59	106
40	1 1/2	90	39	68.5	126
50	2	111	50	76	126

主要技术参数

公称压力:1.6MPa
适用介质:水、非腐蚀性液体
工作温度:-10°C~100°C
标准:管螺纹符合ISO228标准

Main technical parameters

Nominal pressure: 1.6MPa
Applicable medium: water, non corrosive liquid
Working temperature: -10°C ~ 100 °C
Standard: Pipe threads comply with ISO228 standard

黄铜减压阀
Brass pressure reducing valve

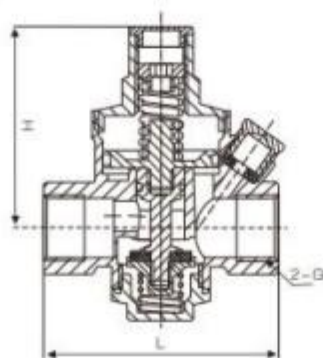

外形尺寸 Overall dimensions

单位: mm

DN	SIZE	L	H	G
15	1/2	67.4	61	1/2
20	3/4	70	63	3/4
25	1	73	66	1
32	1 1/4	82	78	1 1/4
40	1 1/2	92	91	1 1/2
50	2	104	102.5	2

主要技术参数

公称压力:1.6MPa
工作温度:0°C≤T≤110°C
出口压力:0.1MPa~0.5MPa
适用介质:水、非腐蚀性液体
标准:测试压力符合ISO208标准

Main technical parameters

Nominal pressure: 1.6MPa
Working temperature: 0 °C ≤ T ≤ 110 °C
Outlet pressure: 0.1MPa~0.5MPa
Applicable medium: water, non corrosive liquid
Standard: Test pressure meets ISO208 standard