



VALVE



**FLUORINE LINED
VALVE SERIES**
衬氟阀门系列

▼ FLUORINE PLASTIC LINED STEEL VALVES 氟塑料衬里钢阀门

氟塑料衬里钢阀门说明：

Fluorine plastic lined steel valves explanation:

由于钢衬氟塑料阀门的应用较广，在工业中使用最多的氟塑料阀门衬里原料有 PTFE、PFA、FEP、PO 四种。其中 PFA、FEP、PO 的流动性很好，而且成型工艺也有多种，它分为传递模塑料成型（挤压）、注塑成型、三维旋转成型。然而 PTFE 的流动性较差，成型工艺有两种，分为模压成型、传递模塑料成型（挤压）。这几种工艺成型的钢衬氟塑料阀门，可在正负压、常温、强腐蚀的条件下使用。

PTFE 的全称叫悬浮聚四氟乙烯树脂，简称 F4。PFA 的全称叫可溶性聚四氟乙烯。FEP 叫聚全氟乙丙烯，简称 F46。Po 的全称叫聚烯烃。

用途与范围：

Purpose and scope :

除了熔融锂、钠和三氟化氯元素除外，几乎能够抵抗任何种类强酸、碱、盐、强氧化剂、（包括王水）、还原剂和各种有机溶剂的作用。一般适合使用在如：化工、石油、炼油、军工、氯碱、制酸、磷肥、制药、染料、农药、化纤、染化、焦化、煤气、冶金、有机冶炼、有机合成、环保工程、水处理、原子能和高纯产品生产（如离子膜电解），粘稠物料输送与操作、饮料、卫生食品等等专业公司。

Due to the wide application of steel lining fluorine plastic valves, in industrial raw materials are used in most of the fluorine plastic valves lining PTFE, PFA, FEP, four PO. The PFA, FEP, PO has a good liquidity, but also has a variety of molding process, it is divided into transfer mold plastic molding (extrusion), injection molding, three-dimensional rotational molding. PTFE poor liquidity, however, there are two kinds of molding process, divided into molding, transfer molding compound forming (extrusion). The several process molding steel lining fluorine plastic valves, can be in pressure, temperature, strong corrosion under the conditions of use.

Call the full name of PTFE suspension PTFE resin, hereinafter referred to as F4. The full name of PFA called soluble ptf. FEP FEP, F46 for short. The Po is the full name of polyolefin.

In addition, other than melt lithium, sodium, and chlorine trifluoride, resistant to almost any kind of acid, alkali, salts, strong oxidizing agents, (including aqua regia), a reducing agent, and various organic solvents. Generally suitable for use in such as: chemical, petroleum, refining, military, chlor-alkali, acid, fertilizer, pharmaceuticals, dyes, pesticides, chemical fiber, dyeing, coke, gas, metallurgy, smelting organic, organic synthesis, environmental engineering, water treatment, atomic energy and high-purity products (such as ion-exchange membrane electrolysis), viscous material handling and operation, beverages, health food, and so professional company.

阀门衬里成型工艺分类：

The valve lining molding process classification:

一、模压成型

模压成型只限于结构简单的阀门，用悬浮聚乙烯树脂（PTFE）中粒度制作，简称 F4。模压时材料要控制在 19-22℃ 左右（因为气温高了材料容易结团，模压时还要消除了内应力），压力一般控制在 350kg/C 随着形状的大小来保压，然后烧结升温、保温、降温三个过程再机加工。目前钢衬四氟蝶阀、半衬四氟旋塞阀，就是用的这种工艺制作。可耐正负压。

二、传递模塑料成型（挤压）

是指工件（体、盖、瓣等）与衬里层材料一起放在高温烧结炉内加温，升到一定的温度取出，在压机压力的受压下把衬里的材料慢慢传递到衬里工件的各部位，这种成型方法叫传递模塑法，又名挤压成型。衬里材料一般采用 F46、PFA、PO 等可溶性工程塑料，改性 PTFE 也可以用此工艺，目前钢衬氟塑料球阀、蝶阀、截止阀、调节阀、止回阀、隔膜阀、全衬旋塞阀、闸阀就是用的这种工艺制作。

三、注塑成型

是指流动性比较好的氟塑料如 PFA、FEP、PO 改性 PTFE 等，这些材料都可以注塑成型，工艺简单，周期短，一次性成型等优点。

四、三维旋转成型

首先把工件（体、盖、瓣等）加温到一定的程度把高流动性的氟塑料热塑性树脂粉末放在一个空的模子里待加衬里，加热工件，同时使模子绕自转轴和公转轴旋转，这样工件的内表面就涂上了层均匀的熔融树脂。利用三维旋转成型方法，可以生产厚度均匀的无缝衬里，这种衬里具有氟碳树脂的优良性能，与耐负压无可比的致密性，钢衬 PO 阀门就是用的这种工艺。

五、各种衬里材料的使用温度

钢衬 PTFE 阀门可在 -20℃ ~ 160℃ 以内的长期使用，钢衬 F46 阀门可在 -20℃ ~ 150℃ 以内长期使用，钢衬 PFA 阀门可在 -20℃ ~ 180℃ 长期使用，钢衬 PO 阀门可在 -20℃ ~ 80℃ 以内长期使用，可耐高浓度的酸、碱、盐介质。

1.Molding

Moulding is limited to simple structure of the valve, made of suspended polyethylene resin (PTFE) granularity, hereinafter referred to as F4. Moulding materials to the control in 19-22 °C or so (because of the high temperature the material easy to cluster, eliminates the internal stress even when moulded), pressure control in commonly 350 kg/C with shape to the size of the pressure, and then three sintering temperature, heat preservation, cooling process and machining. The steel lining four fluorine butterfly, half lining four fluorine plug valve, is made of the process. Resistant to pressure.

2.Transfer mold plastic molding (extrusion)

Refers to artifacts (body, cover, disc, etc.) with the lining material in high temperature sintering furnace heating, up to a certain temperature and pressure in compressor under the pressure of the lining of the lining material slowly passed to the various parts of the workpiece, the molding method call transfer molding, extrusion and name. Lining material generally USES F46, PFA, PO, such as soluble engineering plastics, modified PTFE can also use this technology, the current steel lining fluorine plastic ball valve, butterfly valve, globe valve, regulating valve, check valve, diaphragm valve, full line plug valve, gate valve is made of the process.

3.Injection molding

Liquidity refers to a good fluorine plastic, such as PFA, FEP, PO modified PTFE. These materials can be injection molding process is simple, cycle short, one-time molding, etc.

4.Three-dimensional rotational molding

First turn on the workpiece (body, cover, disc, etc.) heated to a certain extent the high liquidity of fluorine plastic hot plastic resin powder on an empty mold to add the lining, heating workpiece, at the same time make the mold around the spin axis and the axis of rotation, so that the inner surface of the workpiece is coated with a layer of molten resin. Using the method of three-dimensional rotational molding, can produce seamless lining thickness, the lining has good performance of fluorocarbon resin, with no negative pressure resistance compare to tightness, steel liner PO valve is to use this technology.

5.The use of all kinds of lining material temperature

Steel lining PTFE valve within - 20 °C ~ 160 °C can be of use for a long time, the valve can be in steel lining F46-20 °C ~ 150 °C for long-term use, valve can be in steel lining PFA - 20 °C ~ 180 °C for long-term use, valve can be in steel liner PO - 20 °C ~ 80 °C using for a long time, resistant to high concentrations of acid, alkali, salt medium.

▼ TYPES OF FLUORO-PLASTICS LINING IN VALVES

衬氟阀门衬里几种材料

1、聚全氟乙烯FEP (F46) Polyfluoroethylene FEP (F46)

适用介质 Applicable medium	任何有机溶剂或试剂，稀或浓无机酸，碱，酮，芳烃，氯化烃等。 Any organic solvent or reagent, dilute or concentrated inorganic acid, alkali, ketone, aromatic hydrocarbon, chlorinated hydrocarbon, etc.
使用温度 Operating temperature	-85°C ~ 150°C
特点 Characteristic	力学，电性能和化学稳定性基本与F4相同，但突出优点是动击韧性高，有极好的耐候性和辐射性。 The mechanical, electrical and chemical stability are basically the same as F4, but the outstanding advantages are high dynamic impact toughness, excellent weather resistance and radiation.

2、聚三氟乙烯PCTEF (F3) Polytetrafluoroethylene PCTEF (F3)

适用介质 Applicable medium	各种有机溶剂，无机腐蚀性液体(氧化性酸类) Various organic solvents, inorganic corrosive liquids (oxidizing acids)
使用温度 Operating temperature	-195°C ~ 120°C
特点 Characteristic	耐热性，电性能和化学稳定性仅次于F4，机械强度，蠕变性能，硬度比F4好些 Heat resistance, electrical property and chemical stability are only inferior to F4, and mechanical strength, creep property and hardness are better than F4

3、聚丙烯: RPP Polypropylene: RPP

适用介质 Applicable medium	无机盐类的水溶液,无机酸类,碱类的稀或浓溶液。 Aqueous solutions of inorganic salts, dilute or concentrated solutions of inorganic acids and alkalis.
使用温度 Operating temperature	-14°C ~ 80°C
特点 Characteristic	最轻的塑料之一，屈服，拉伸和压缩强度，硬度均优于低压聚乙烯，有很突出的刚性，耐热性好，易成型，价廉。改性后冲击性，流动性，弯曲弹性。 One of the lightest plastics, with superior yield, tensile and compressive strength, and hardness compared to low-pressure polyethylene. It has outstanding rigidity, good heat resistance, easy molding, and is cost-effective. Modified dynamic impact, flowability, and bending elasticity.

4、聚氟乙烯:硬质PVC Polyfluoroethylene: hard PVC

适用介质 Applicable medium	耐水，浓碱，非氧化性酸，链烃，油和臭氧等。 Resistant to water, concentrated alkali, non oxidizing acids, chain hydrocarbons, oil, and ozone.
使用温度 Operating temperature	0°C ~ 55°C
特点 Characteristic	机械强度较高，化学稳定性及介电性能优良，耐油性和抗老性也较好，易熔接及粘合，价格较低。 High mechanical strength, excellent chemical stability and dielectric properties, good oil resistance and anti-aging resistance, easy fusion and bonding, low price.

5、聚四氟乙烯PTFE(F4) Polytetrafluoroethylene PTFE (F4)

适用介质 Applicable medium	强酸，强碱，强氧化剂等。 Strong acids, bases, oxidizing agents, etc.
使用温度 Operating temperature	-200°C ~ 180°C
特点 Characteristic	具有优异的化学稳定性，有很高的耐热性，耐寒性，摩擦系数很低，是极好的自润滑材料，但机械性能较低，流动性差，热膨胀大。 It has excellent chemical stability, high heat resistance, cold resistance, and low friction coefficient. It is an excellent self-lubricating material, but has low mechanical properties, poor fluidity, and large thermal expansion.

6、可溶性四氟性能(PFA) Fusible Tetrafluoroethylene Performance (PFA)

适用介质 Applicable medium	强酸，强碱，强氧化剂等。 Strong acids, bases, oxidizing agents, etc.
使用温度 Operating temperature	-200°C ~ 180°C
特点 Characteristic	具有良好的热塑性，可用一般热塑性塑料的加工方法，如注塑，如挤出，吹塑等法成型。 It has good thermoplastic properties and can be processed using general thermoplastic methods such as injection molding, extrusion, and extrusion molding.

7、聚偏氟乙烯PVDF(F2) Polyvinylidene fluoride PVDF (F2)

适用介质 Applicable medium	耐大多数化学药品和溶剂。 Resistant to most chemicals and solvents
使用温度 Operating temperature	-70°C ~ 100°C
特点 Characteristic	拉伸强度与压缩强度好，耐弯折、耐候、耐辐射、耐光和老化等，韧性好，易成型。 Good tensile and compressive strength, resistant to bending, weathering, radiation, light, and aging, with good toughness and easy forming

8、聚烯烃: PO Polyolefins: PO

适用介质 Applicable medium	各种浓度的酸碱盐及某些有机溶剂。 Various concentrations of acid, alkali, salt, and certain organic solvents.
使用温度 Operating temperature	-58°C ~ 80°C
特点 Characteristic	是目前世界最理想的防腐材料，已广泛用于旋转成型的大型设备和管道件内衬。 It is currently the most ideal anti-corrosion material in the world and has been widely used for the lining of large equipment and pipeline components in rotary molding.

9、氟塑料合金: F501 Fluoroplastic alloy: F501

适用介质 Applicable medium	酸、碱、强氧化剂和有机溶剂等 Acids, alkalis, strong oxidizing agents, and organic solvents, etc
使用温度 Operating temperature	250长期使用 250 long-term use
特点 Characteristic	耐高温、耐腐蚀、电绝缘性好和表面不粘性 High temperature resistance, corrosion resistance, good electrical insulation, and non adhesive surface

蝶阀结构形式 Structural form of butterfly valve	代号 Code	隔膜阀结构形式 Diaphragm valve structure	代号 Code	旋塞阀结构形式 Structural form of plug valve	代号 Code
密封性单偏心 Sealing single eccentricity	0	屋脊式 Ridge style	1	直通式 Straight through type	3
中心垂直板式 Center vertical plate type	1	直通流道 Straight passage	5	T形三通式 T-shaped three-way	4
三偏心 Triple eccentricity	3	Y型角式流道 Y-shaped angle flow channel	8	四通式 Four way equation	5
		直流板式 DC board type	6		

止回阀结构形式 Structural form of check valve		代号 Code
升降 Lifting	直通式 Straight through type	1
	立式 vertical	2
旋启 Swing	单瓣式 Single lobe type	4
	多瓣式 Multi petal type	5
	双瓣式 Double petal type	6
	蝶式 Butterfly type	7

阀座密封面或衬里材料代号用汉语拼音字母表示, 按下表的规定。
The material code for the sealing surface or lining of the valve seat is represented by Chinese pinyin letters, as specified in the following table.

阀座密封面或衬里材料 Valve seat sealing surface or lining material	代号 Code	阀座密封面或衬里材料 Valve seat sealing surface or lining material	代号 Code
铜合金 copper alloy	T	渗氮钢 Helium infiltrated steel	D
橡胶 rubber	X	硬质合金 Hard alloy	Y
尼龙塑料 Nylon plastic	N	衬胶 Rubber lining	J
氟塑料 Fluoroplastics	F	衬铅 Lead lining	Q
锡基轴承合金(巴氏合金) Tin based bearing alloy (Babbitt alloy)	B	搪瓷 enamel	C
Cr13系不锈钢 Cr13 series stainless steel	H	渗硼钢 Boronized steel	P
奥氏体不锈钢 austenitic stainless steel	R	塑料 Plastic	S
陶瓷 ceramics	G	蒙乃尔合金 Monel alloy	M
衬铝镍合金 Aluminum nickel alloy lining	L		

注: 由阀体直接加工的阀座密封面材料代号用“W”表示, 当阀座和阀壁(闸板)密封面材料不同时, 用低硬度材料代号表示(隔膜阀除外)。

- 压力代号: 1. 阀门使用的压力级符合GB/T 1048的规定时, 采用GB/T 1048标准10倍的兆帕单位(Mpa)数值表示。
2. 当介质最高温度超过425℃时, 标注最高工作温度下的工作压力代号。
3. 压力等级采用磅级(lb)或K级单位的阀门, 在型号编制时, 应在压力代号后有lb或K的单位符号。
4. PN ≤ 1.6MPa的灰铸铁阀体和PN ≥ 2.5MPa的碳钢阀体省略本代号。
- Note: The material code for the sealing surface of the valve seat directly processed by the valve body is used "W" indicates that when the sealing surface materials of the valve seat and valve wall (gate) are different, the low hardness material code is used (excluding diaphragm valves)
- Pressure code: 1. When the pressure level used by the valve complies with the provisions of GB/T 1048, it is expressed in megapascals (Mpa) 10 times the standard GB/T 1048.
2. When the medium quality is high and the temperature exceeds 425 °C, indicate the working pressure code at the highest working temperature.
3. For valves with pressure ratings in pounds (lb) or K units, the unit symbol for lb or K should be included after the pressure code column in the model designation.
4. This code is omitted for gray cast iron valve bodies with PN ≤ 1.6MPa and carbon copper valve bodies with PN ≥ 2.5MPa.

阀体材料代号用汉语拼音字母表示, 按下表的规定。The material code of the valve body is represented by Chinese pinyin letters, as specified in the following table.

阀座密封面或衬里材料 Valve seat sealing surface or lining material	代号 Code	阀座密封面或衬里材料 Valve seat sealing surface or lining material	代号 Code
碳钢 Carbon steel	C	铬镍钼系不锈钢 Chromium nickel molybdenum stainless steel	R
Cr13系不锈钢 Cr13 series stainless steel	H	塑料 Plastic	S
铬钼系钢 Chromium molybdenum series steel	I	铜及铜合金 Copper and copper alloys	T
可锻铸铁 Malleable iron	K	钛及钛合金 Titanium and titanium alloys	Ti
铝合金 Aluminium alloy	L	铬镍钒钢 Chromium nickel vanadium steel	V
铬镍系不锈钢 Chromium nickel stainless steel	P	灰铸铁 Grey cast iron	Z
球墨铸铁 Ductile iron	Q	增强聚丙烯 Reinforced polypropylene	RPP

注: CF3、CF8、CF3M、CF8M等材料牌号可直接标注在阀体上。Note: Material grades such as CF3, CF8, CF3M, and CF8M can be directly marked on the valve body.

衬氟蝶阀

Fluorine-lined butterfly valve

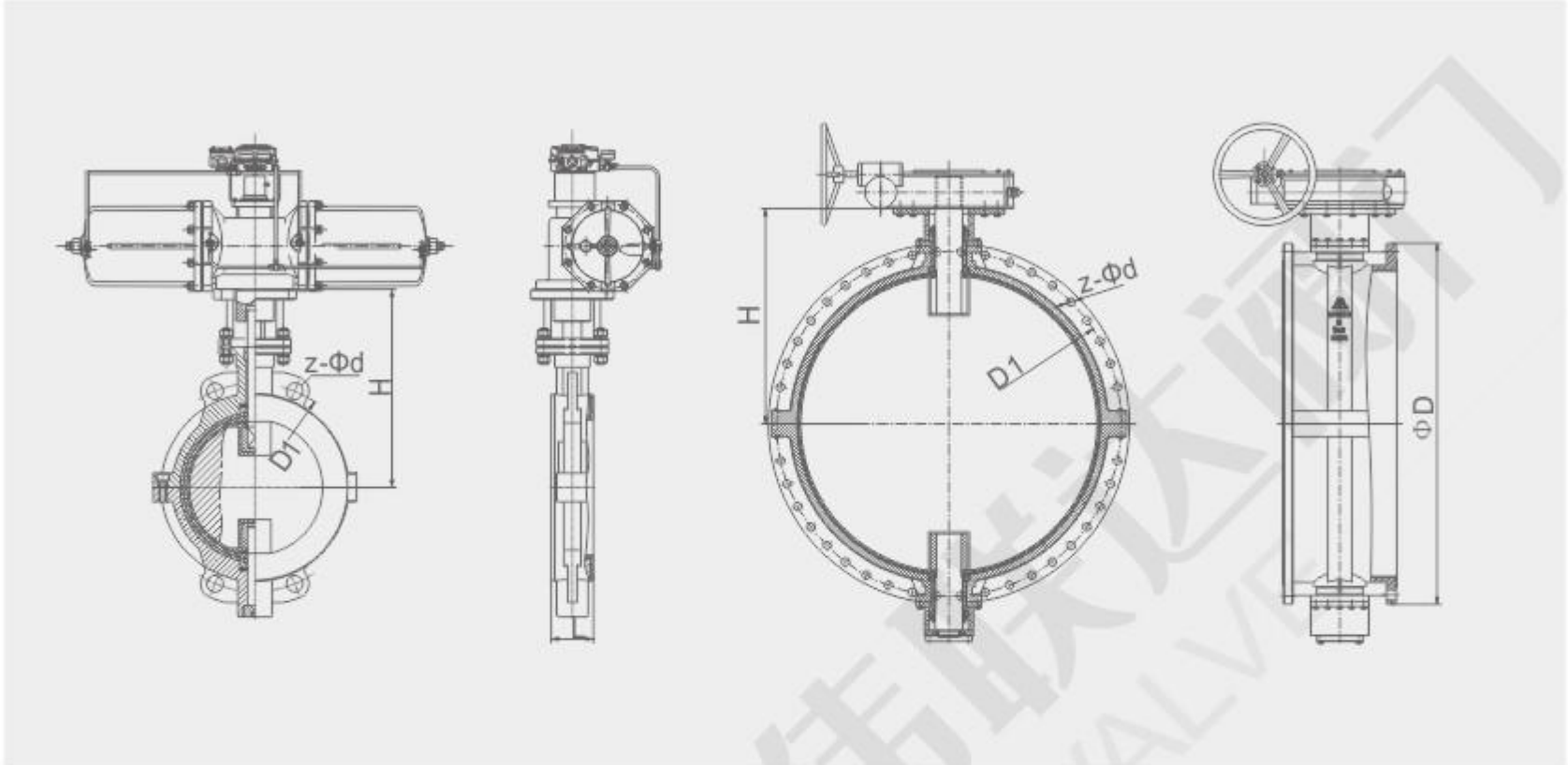

衬氟蝶阀用途及特点

衬氟蝶阀采用带有球形密封表面的衬聚四氟乙烯包衬蝶板，该阀门操作轻便，严密的密封性能，超长的使用寿命；可作快速切断或调节流量之用。适用于要求可靠密封和良好调节特性的场合。

阀体采用分体式，阀轴两端的密封由蝶板与阀座之间的旋转基面加氟橡胶来控制；保证阀轴不与腔内流体介质接触。广泛适用于各种不同类型工业管道中液体和气体（包括蒸气）的输送，有严重腐蚀性介质的使用场合，如：硫酸、氢氟酸、磷酸、氯气、强碱、王水等具有强腐蚀性的介质。

主要特点

- 1、设计新颖、合理、结构独特，重量轻，启闭迅速。
- 2、操作力矩小，操作方便，省力灵巧，90°回转开启迅速。
- 3、小巧轻便，容易拆装及维修，并可在任意位置安装。
- 4、密封件可以更换，密封性能可靠达到双向密封零泄漏。
- 5、密封材料耐老化、耐腐蚀，使用寿命长等特点。
- 6、流量特性趋直线，调节性能好。
- 9、蝶板与阀杆的连接采用无销钉结构，克服了有可能的内泄漏点。
- 10、蝶板可根据用户要求喷涂覆层，如尼龙或聚四氟类。
- 11、该阀可设计成法兰连接和对夹连接。
- 12、驱动方式多种可选择手动、电动或气动，执行器可选带电讯号反馈指示及各类附件以实现自动化操作

Uses and Features

The fluorine-lined butterfly valve adopts a PTFE-lined butterfly plate with a spherical sealing surface. The valve is easy to operate, has tight sealing performance, and has a long service life; it can be used for quick shut-off or flow regulation. Suitable for applications requiring reliable sealing and good regulation characteristics.

The valve body adopts a split type, and the seal at both ends of the valve shaft is controlled by the rotating base surface between the butterfly plate and the valve seat plus fluorine rubber; it ensures that the valve shaft does not come into contact with the fluid medium in the cavity. It is widely used in the transportation of liquid and gas (including steam) in various types of industrial pipelines, and the use of severe corrosive media, such as: sulfuric acid, hydrofluoric acid, phosphoric acid, chlorine, strong alkali, aqua regia, etc. sexual medium.

Main feature

1. Novel and reasonable design, unique structure, light weight, quick opening and closing.
2. The operating torque is small, the operation is convenient, labor-saving and smart, and the 90° rotation can be opened quickly.
3. Small and light, easy to disassemble and maintain, and can be installed in any position.
4. The seals can be replaced, and the sealing performance is reliable and can achieve zero leakage of bidirectional sealing.
5. The sealing material has the characteristics of aging resistance, corrosion resistance and long service life.
6. The flow characteristics tend to be straight, and the adjustment performance is good.
9. The connection between the butterfly plate and the valve stem adopts a pin-free structure, which overcomes the possible internal leakage point.
10. The butterfly plate can be sprayed with coating according to user requirements, such as nylon or PTFE.
11. The valve can be designed as flange connection and wafer connection.
12. Various drive modes can be selected from manual, electric or pneumatic, and the actuator can be selected with electric signal feedback indication and various accessories to realize automatic operation

国标衬氟蝶阀
GB Fluorine-lined butterfly valve

F

衬氟阀门系列
Fluorine Lined Valve Series

基本型号 Basic model							
公称压力PN0.6-1.6(MPa)150Lb公称口径DN40-1200(MM)/in3"~48" Nominal pressure PN0.6-1.6 (MPa) 150Lb, nominal diameter DN40-1200 (MM)/in3 "48"							
手动 Manual	D1/41F/P(半衬Semi lining)	蜗轮传动 Worm gear transmission	D37/41F/P(半衬Semi lining)	气动 Pneumatic	D67/41F/P(半衬Semi lining)	电动 Electric	D97/41F/P(半衬Semi lining)
	D7/41F _s (全衬里Fully lined)		D37/41F _s (全衬里Fully lined)		D67/41F _s (全衬里Fully lined)		D97/41F _s (全衬里Fully lined)
	D7/41F _f (全衬里Fully lined)		D37/41F _f (全衬里Fully lined)		D67/41F _f (全衬里Fully lined)		D97/41F _f (全衬里Fully lined)
	D7/41F _{ss} (全衬里Fully lined)		D37/41F _{ss} (全衬里Fully lined)		D67/41F _{ss} (全衬里Fully lined)		D97/41F _{ss} (全衬里Fully lined)
	D7/41F _{ss} (全衬里Fully lined)		D37/41F _{ss} (全衬里Fully lined)		D7/41F _{ss} (全衬里Fully lined)		D97/41F _{ss} (全衬里Fully lined)

蝶阀驱动力矩参考表 Butterfly valve drive torque reference table

公称口径 Nominal Diameter	DN	40	50	65	80	100	125	150	200	250	300	350	400
	inch	1 1/2	2	2 1/2	3	4	5	6	8	10	12	14	16
PN6,PN10	N/M	37	45	75	110	140	190	250	360	530	800	1150	1500
PN16,Class150	N/M	50	90	120	160	200	250	350	500	750	1000	1500	1900
公称口径 Nominal Diameter	DN	450	500	600	700	800	900	1000	1200	1400	1600	1800	2000
	inch	18	20	24	28	32	36	40	48	56	64	72	80
PN6,PN10	N/M	2200	3000	4500	6500	9000	14000	22500	30000	46500	56210	61861	71200
PN16,Class150	N/M	2500	3500	6000	7500	10000	15200	24800	32300	49200	61200	68000	78600

主要零部件材料表 Material table of main parts

序号 NO	零件名称 Name	球磨铸铁 Nodular cast iron	铸钢 Cast steel	不锈钢 Stainless steel		超低碳不锈钢 Ultra low carbon stainless steel	
		Q	C	P	R	R1	R1
1	上、下阀体、阀盖 Upper and lower valve bodies, valve covers	QT450-10	WCB	CF8	CF8M	CF3	CF3M
2	蝶板 Disc	WCB	WCB	CF8	CF8M	CF3	CF3M
3	衬里层/阀座 Lining layer/valve seat	PFA(F ₄)PTFE(F ₂)PCTFE(F ₃)FEP(F ₆)PFA(可溶F ₄)PO(聚烯)					
4	O型圈 O-ring	FPM(氟橡胶Viton)					
5	弹性条(垫) Elastic strip (pad)	S1(硅橡胶Silastic)					
6	螺栓 Bolt	A193 B7	A193 B7	A193 B8	A193 B8	A193 B8	A193 B8
7	螺母 Nut	A194 2H	A194 2H	A194 8	A194 8	A194 8M	A194 8M
8	手柄 Handle	WCB					

国标衬氟蝶阀

GB Fluorine-lined butterfly valve

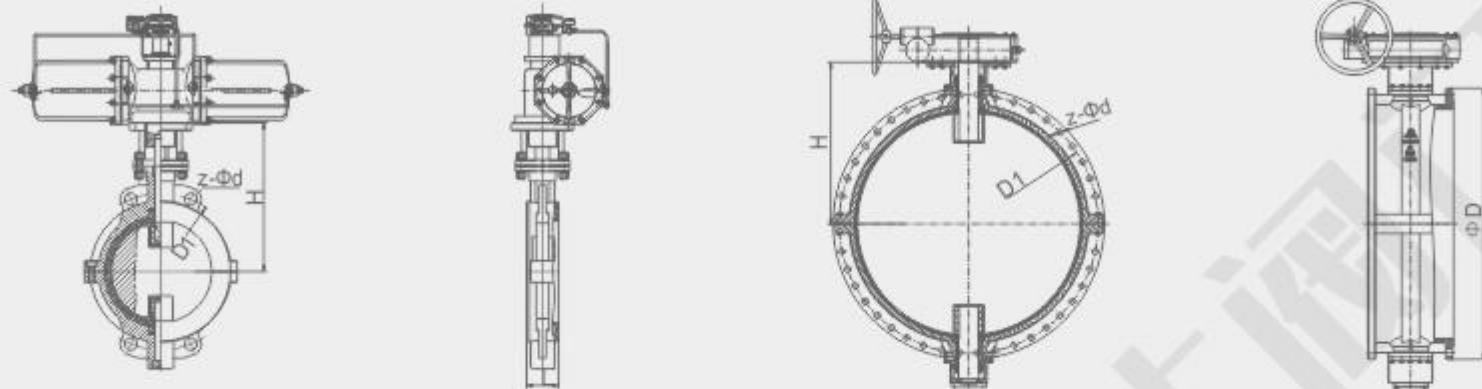

产品特性:

设计标准: HG/T3704 GB/T122238 API609;
结构长度: GB/T12221 ASME B16.10 HG/T3704;
法兰标准: JB/T79 GB/T9113 HG/T20592 ASME B16.5/47;
连接方式: 对夹式、法兰式
公称压力: PN0.6~1.0MPa 150Lb
检验试验: GB/T13927 API598
驱动方式: 手动/电动/气动;

Product Features:

Design standards: HG/T3704 GB/T122238 API609;
Structure length: GB/T12221 ASME B16.10 HG/T3704;
Flange standard: JB/T79 GB/T9113 HG/T20592 ASME B16.5/47;
Connection method: wafer type, flange type
Nominal pressure: PN0.6~1.0MPa 150Lb
Inspection test: GB/T13927 API598
Drive mode: manual/electric/pneumatic;

PN6/PN10 国标衬氟蝶阀

公称直径 Nominal Diameter		标准值 Standard value								参考值 Reference value			
DN (mm)	NPS (inch)	L		PN0.6(MPa)			PN1.0(MPa)			D0	H	重量weight(kg)	
		对夹 Wafer	法兰 Flange	D	D1	Z-Φd	D	D1	Z-Φd			D41	D71
40	1 1/2	33	106	130	100	4-Φ14	150	110	4-Φ18	160	140	7.68	3.05
50	2	43	108	140	110	4-Φ14	165	125	4-Φ18	200	145	7.68	3.05
65	2 1/2	46	112	160	130	4-Φ14	185	145	8-Φ18	250	155	9.65	3.59
80	3	46	114	190	150	4-Φ18	200	160	8-Φ18	250	165	10.58	4.09
100	4	52	127	210	170	4-Φ18	220	180	8-Φ18	250	180	13.84	5.29
125	5	56	140	240	200	8-Φ18	250	210	8-Φ18	300	203	17.88	7.43
150	6	56	140	265	225	8-Φ18	285	240	8-Φ22	300	225	22.94	9.29
200	8	60	152	320	280	8-Φ18	340	295	8-Φ22	200*	275	39.5	16.16
250	10	68	165	375	335	12-Φ18	395	350	12-Φ22	200*	315	53.64	27.4
300	12	78	178	440	395	12-Φ22	445	400	12-Φ22	240*	348	67.45	39.4
350	14	78	190	490	445	12-Φ22	505	460	16-Φ22	240*	415	80.01	48.6
400	16	102	216	540	495	16-Φ22	565	515	16-Φ26	280*	460	133.29	73
450	18	114	222	595	550	16-Φ22	615	565	20-Φ26	280*	500	146	79.2
500	20	127	229	645	600	20-Φ22	670	620	20-Φ26	320*	530	203.76	121
600	24	154	267	755	705	20-Φ26	780	725	20-Φ30	320*	610	256	162
700	28	165	292	860	810	24-Φ26	895	840	24-Φ30	360*	675	413	220
800	32	190	318	975	920	24-Φ30	1015	950	24-Φ33	360*	805	491	286
900	36	203	330	1075	1020	24-Φ30	1115	1050	28-Φ33	380*	995	530	390
1000	40	216	410	1175	1120	28-Φ30	1230	1160	28-Φ36	400*	1110	1140	960
1200	48	254	470	1405	1340	32-Φ33	1455	1380	32-Φ39	400*	1130	1320	1220
1400	56	297	530	1630	1560	36-Φ36	1675	1590	36-Φ42	500*	1140	2630	2200
1600	64	318	600	1830	1760	40-Φ36	1915	1820	40-Φ48	600*	1162	3300	2930
1800	72	356	670	2045	1970	44-Φ39	2115	2020	44-Φ48	600*	1260	4200	3860
2000	80	406	706	2265	2180	48-Φ42	2325	2230	48-Φ48	600*	1310	4780	4050

注: 图中重量为阀门重量, 不含操作机构重量, 更多重量请咨询永联。

Note: The weight in the figure is the weight of the valve, excluding the weight of the operating mechanism. For more weights, please consult Yonglian.

法兰连接蝶阀

Flange connection butterfly valve

F

衬氟阀门系列
Fluorine Lined Valve Series

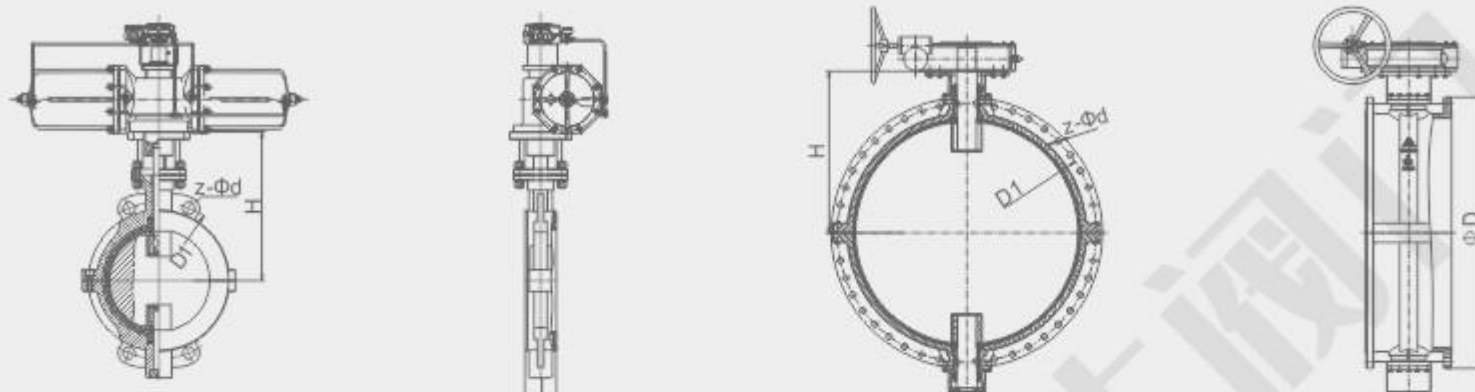

产品特性:

设计标准: HG/T3704 GB/T122238 API609;
结构长度: GB/T12221 ASME B16.10 HG/T3704;
法兰标准: JB/T79 GB/T9113 HG/T20592 ASME B16.5/47 HG/T20623
连接方式: 对夹式、法兰式
公称压力: PN0.6~1.0MPa 150Lb
检验试验: GB/T13927 API598
驱动方式: 手动/电动/气动;

Product Features:

Design standards: HG/T3704 GB/T122238 API609;
Structure length: GB/T12221 ASME B16.10 HG/T3704;
Flange standard: JB/T79 GB/T9113 HG/T20592 ASME B16.5/47 HG/T20623
Connection method: wafer type, flange type
Nominal pressure: PN0.6~1.0MPa 150Lb
Inspection test: GB/T13927 API598
Drive mode: manual/electric/pneumatic;

PN 16 法兰连接蝶阀

公称通径 Nominal Diameter		标准值 Standard value								参考值 Reference value		
DN (mm)	NPS (inch)	L		PN1.6(MPa)			150LB			H	重量weight(kg)	
		对夹 Wafer	法兰 Flange	D	D1	Z-Φd	D	D1	Z-Φd		D41	D71
40	1 1/2	33	106	150	110	4-Φ18	125	98.4	4-Φ16	145	7.68	3.05
50	2	43	108	165	125	4-Φ18	150	120.7	4-Φ18	150	7.68	3.05
65	2 1/2	46	112	185	145	8-Φ18	180	139.7	4-Φ18	160	9.65	3.59
80	3	46	114	200	160	8-Φ18	190	152.4	4-Φ18	170	10.58	4.09
100	4	52	127	220	180	8-Φ18	230	190.5	8-Φ18	185	13.84	5.29
125	5	56	140	250	210	8-Φ18	255	215.9	8-Φ22	210	17.88	7.43
150	6	56	140	285	240	8-Φ22	280	241.3	8-Φ22	230	22.94	9.29
200	8	60	152	340	295	12-Φ22	345	298.5	8-Φ22	285	39.5	16.16
250	10	68	165	405	355	12-Φ26	405	362	12-Φ26	325	53.64	27.4
300	12	78	178	460	410	12-Φ26	485	431.8	12-Φ26	360	67.45	39.4
350	14	78	190	520	470	16-Φ26	535	476.3	12-Φ30	430	80.01	48.6
400	16	102	216	580	525	16-Φ30	595	539.8	16-Φ30	475	133.29	73
450	18	114	222	640	585	20-Φ30	635	577.9	16-Φ33	525	146	79.2
500	20	127	229	715	650	20-Φ33	700	635	20-Φ33	565	203.76	121
600	24	154	267	840	770	20-Φ36	815	749.3	20-Φ36	620	256	162
700	28	165	292	910	840	24-Φ36	925	863.6	28-Φ36	686	413	220
800	32	190	318	1025	950	24-Φ39	1060	977.9	28-Φ42	815	491	286
900	36	203	330	1125	1050	28-Φ39	1170	1085.8	32-Φ42	1010	450	390
1000	40	216	410	1255	1170	28-Φ42	1290	1200.2	36-Φ42	1110	975	960
1200	48	254	470	1485	1390	32-Φ48	1510	1422.4	44-Φ42	1130	820	1220
1400	56	297	530	1685	1590	36-Φ48	1745	1651	48-Φ48	1210	2630	2200
1600	64	318	600	1930	1820	40-Φ56	-	-	-	1280	3300	2930
1800	72	356	670	2130	2020	44-Φ56	-	-	-	1320	4200	3860
2000	80	406	760	2345	2230	48-Φ62	-	-	-	1365	4950	4130

注: 1. 上图所示法兰数值为化工部标准, 如需其它标准请在订货时注明。

2. 上表所列数值为标准发尺寸, 其中美标尺寸当NPS≤24时按B16.5, 当NPS > 24时按B16.47。

Note: 1. The flange values shown in the above figure are the standards of the Ministry of Chemical Industry. If other standards are required, please indicate them when ordering.
2. The values listed in the above table are standard dimensions, with B16.5 for American standard dimensions when NPS ≤ 24 and B16.47 for NPS > 24.

气动衬氟蝶阀 ZSHFW-^{1.0}/_{2.5} K/B
Pneumatic fluorine-lined butterfly valve

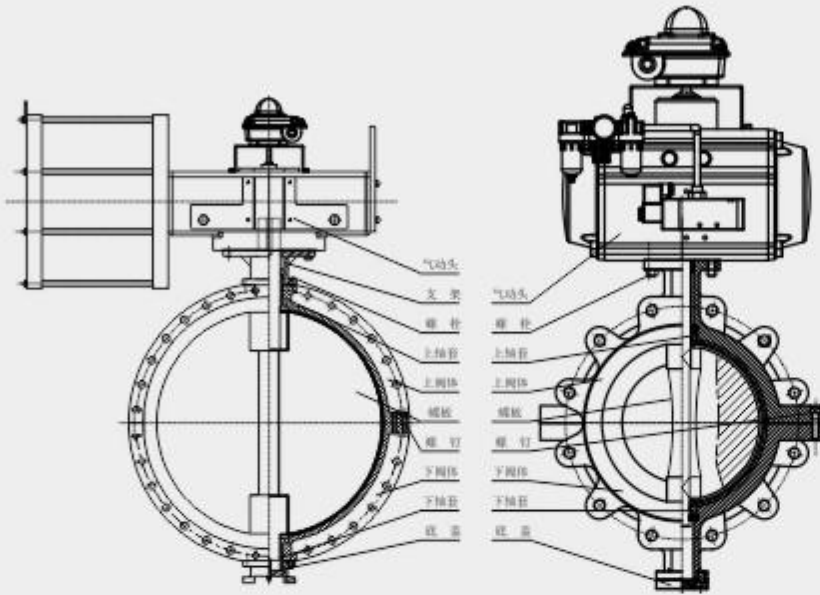

图一单作用气动衬氟蝶阀

图二双作用气动衬氟蝶阀

产品特性:

设计标准: HG/T3704 GB/T122238 API609;
结构长度: GB/T12221 ASME B16.10 HG/T3704;
法兰标准: JB/T79 GB/T9113 HG/T20592 ASME B16.5/47 HG/T20623
连接方式: 对夹式、法兰式、凸耳式
公称压力: PN0.6~1.0MPa 150Lb
检验试验: GB/T13927 API598
驱动方式: 手动/电动/气动;

Product Features:

Design standards: HG/T3704 GB/T122238 API609;
Structure length: GB/T12221 ASME B16.10 HG/T3704;
Flange standard: JB/T79 GB/T9113 HG/T20592 ASME B16.5/47;
Connection method: wafer type, flange type
Nominal pressure: PN0.6~1.0MPa 150Lb
Inspection test: GB/T13927 API598
Drive mode: manual/electric/pneumatic;

一. 用途与特点

该型气动衬氟塑蝶阀属于D671和D641 对夹 / 法兰衬氟蝶阀系列, 它由两种执行机构分别和衬氟蝶阀组成, 执行机构采用气动活塞单作用 (带弹簧复位) 执行器或气动活塞双作用 (无弹簧复位) 执行器, 单作用执行器: 气路为单气路控制, 带有弹簧复位功能, 转动力矩比双作用小。双作用执行器: 气路为双气路控制, 无弹簧复位功能, 但转动力矩比单作用大。衬氟蝶阀阀体内腔, 均有抗腐蚀的氟塑料 (PTFE/FEP/PFA) 制成衬里, 同时对蝶板和阀杆进行包衬氟塑料, 并在阀座基面内设有硅橡胶衬垫, 用来调节阀座基面预紧, 以达到与蝶板密封性能。阀体采用分离式, 阀轴两端的密封由蝶板与阀座之间的旋转基面靠氟橡胶圈来控制, 从而使阀轴不与腔内介质接触, 保证了密封无泄漏。该阀流路简单, 通径蝶芯, 具有阻力小, 流量系数大的优点, 适用于对酸、碱、氯气等强腐蚀介质的切断或调节之用, 可广泛应用于石化、电力、冶金、轻纺等工业部门的自动化装置上。

Uses And Features

This type pneumatic rubber fluorine plastic butterfly valve belong to the clip/flange D671 and D641 fluorine-butterfly butterfly valve series, it consists of two actuators respectively and fluorine-butterfly butterfly valve and actuator adopts pneumatic piston single acting (spring reset) actuators or pneumatic piston (no spring return actuators with double acting, single acting actuators, pneumatic control for single gas path, with the spring reset function, rotational torque is smaller than dual role. Double-acting actuators, pneumatic control for the gas path, there is no spring reset function, but the rotational torque is larger than single function. Fluorine-butterfly butterfly valve body cavity, has the corrosion resistance of the fluorine plastic lining (PTFE/FEP/PFA), at the same time, the butterfly plate and the valve stem packing fluorine plastic, and the seat base with silicone rubber gasket, used to adjust the seat base pre-tightening, in order to achieve and disc sealing performance. Body has separable, valves at the ends of the shaft seal by the rotation of the between disc and seat base on fluorine rubber ring to control, so that the valve shaft is in contact with the cavity medium, guarantees the seal without leakage. The valve flow is simple, size control core, has a small resistance and flow coefficient of the big advantages, suitable for acid, alkali, strong corrosive medium such as chlorine gas cut off, or regulating the use of, can be widely used in petrochemical, electric power, metallurgy, textile and other industrial automation device.

国标气动衬氟蝶阀 ZSHFW-^{1.0}/_{2.5} K/B GB Pneumatic fluorine-lined butterfly valve

F

衬氟阀门系列
Fluorine Lined Valve Series

二. 结构与工作原理

该型气动活塞单作用切断衬氟蝶阀（或调节阀），由气动活塞单作用执行器和对夹/法兰衬氟蝶阀组成。如图一所示

该型气动活塞双作用切断衬氟蝶阀（或调节阀），由气动活塞双作用执行器和对夹/法兰衬氟蝶阀组成。如图二所示

当信号压力输入活塞室（单作用）后，此压力在活塞上产生推力，使弹簧组压缩，（双作用无弹簧组）同时与齿轮轴相连的阀杆、蝶板做相应的转动，直至活塞推力与弹簧组被压缩的反作用力相平衡为止，此时齿轮轴不转动，并保持在一位置上，因而实现调节过程控制。另外单作用执行器和双作用执行器，根据控制要求，均可实现快开切断阀或调节阀的控制。

The structure and working principle

This type pneumatic piston single-acting cut fluorine-butterfly butterfly valve (or valve), by the pneumatic piston single-acting actuator and the clip/flange fluorine-butterfly butterfly valve. As shown in figure a

This type pneumatic piston double-acting cutting (or valve), fluorine-butterfly butterfly valve by pneumatic actuators with double acting piston and the clip/flange fluorine-butterfly butterfly valve. As shown in figure 2

When input signal pressure piston chamber (single), the pressure on the piston to produce thrust, the compression spring group, no spring set (double role) and connected to the shaft of the valve stem and disc turn accordingly, until the piston thrust and the compressed spring group reaction is flat Heng so far, the gear shaft does not rotate, and keep in a certain position, thus realize regulating process control. Other single-acting actuator and double-acting actuators, according to the control requirements, all can achieve quick cut-off valve or valve control.

三. 主要零件材料

阀体、碟板：WCB、CF8、CF&M、CF3M、CF3

阀杆：2Cr13、40Cr；17-4 PH

阀座：聚四氟乙烯；(PTFE)PFA、FEP.

衬垫：硅橡胶；

推力器缸体：挤压铝（氧化）；

弹簧：60Si2Mn；

活塞：压铸铝（镀镍）；

密封件：橡胶 O 形圈、NBR；

The major parts material

Valve body and disc plate :WCB, CF8, CF&M, CF3M, CF3

Stem: 2 cr13, 40 cr; 17-4 PH

Seat: ptfе,(PTFE)PFA, FEP.

Packing: silicone rubber;

Thruster block: extruded aluminum (oxide);

Spring: 60 si2mn;

Piston: die casting aluminum (nickel plated);

Seal: rubber o-ring, NBR;

四. 外形尺寸

Overall dimensions

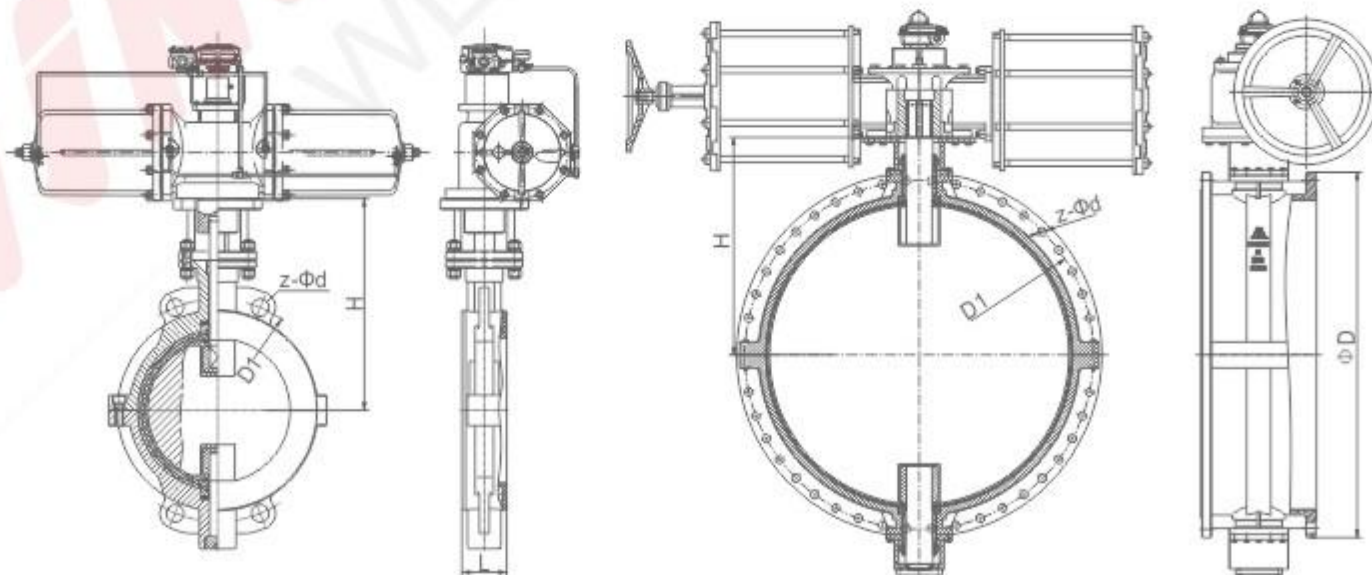

气动对夹衬氟蝶阀
Pneumatic wafer lined fluorine butterfly valve

气动法兰衬氟蝶阀
Pneumatic flange fluorine lined butterfly valve

国标气动衬氟蝶阀ZSHFW-^{1.0}/_{2.5} K/B
GB Pneumatic fluorine-lined butterfly valve

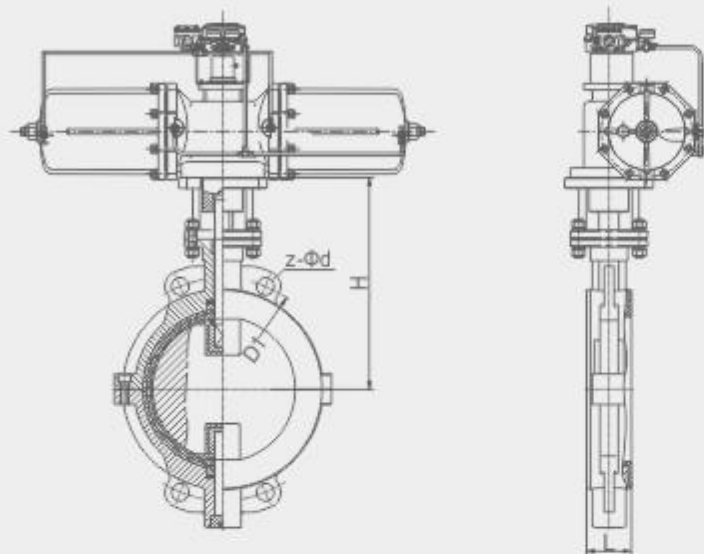

产品标准

设计标准: HG/T3704; GB/T12238
结构长度: GB/T12221 GB/T15188. 2 ASME B16. 10;
法兰标准: GB/T91113. 1 JB/T79. 1, HG/T 20592;
连接方式: 对夹式、法兰式;
检验标准: GB/T13927 API598;
驱动方式: 手动 / 电动 / 气动;

Product Standards

Design criteria: HG/T3704; GB/T12238
Structure length: GB/T12221 GB/T15188. 2 ASME B16. 10;
The flange standard: GB/T91113. 1 JB/T79. 1, HG/T 20592;
Connection mode: Wafer, Flange;
Inspection standard: GB/T13927 API598;
Drive mode: Manual/Electric/Pneumatic;

PN10/PN16 国标气动衬氟蝶阀

单位: mm

公称通径 Nominal Diameter		L		1.0 MPa				1.6 MPa				H
DN (mm)	NPS (inch)	对夹 Wafer	法兰 Flange	D	D1	D2	n-d	D	D1	D2	n-d	
40	1 1/2	33	106	150	110	88	4-Φ18	150	110	88	4-Φ18	136
50	2	43	108	165	125	102	4-Φ18	165	125	102	4-Φ18	143
65	2 1/2	46	112	185	145	122	8-Φ18	185	145	122	8-Φ18	157
80	3	46	114	200	160	138	8-Φ18	200	160	138	8-Φ18	178
100	4	52	127	220	180	158	8-Φ18	220	180	158	8-Φ18	185
125	5	56	140	250	210	188	8-Φ18	250	210	188	8-Φ18	206
150	6	56	140	285	240	212	8-Φ22	285	240	212	8-Φ22	225
200	8	60	152	340	295	268	8-Φ22	340	295	268	12-Φ22	275
250	10	68	165	395	350	320	12-Φ22	405	355	320	12-Φ26	326
300	12	78	178	445	400	370	12-Φ22	460	410	378	12-Φ26	333
350	14	78	190	505	460	430	16-Φ22	520	470	428	16-Φ26	393
400	16	102	216	565	515	482	16-Φ26	580	525	490	16-Φ30	438
450	18	114	222	615	565	532	20-Φ26	640	585	550	20-Φ30	488
500	20	127	229	670	620	585	20-Φ26	715	650	610	20-Φ33	540
600	24	154	267	780	725	685	20-Φ30	840	770	725	20-Φ36	645
700	28	165	292	895	840	800	24-Φ30	910	840	795	24-Φ36	660
800	32	190	318	1015	950	905	24-Φ33	1025	950	900	24-Φ39	720
900	36	203	330	1115	1050	1005	28-Φ33	1125	1050	1000	28-Φ39	785
1000	40	216	410	1230	1160	1110	28-Φ36	1255	1170	1115	28-Φ42	900
1200	48	254	470	1455	1380	1330	32-Φ39	1485	1390	1330	32-Φ48	1070
1400	56	279	530	1675	1590	1535	36-Φ42	1685	1590	1530	36-Φ48	1130
1600	64	318	600	1915	1820	1760	40-Φ48	1930	1820	1750	40-Φ56	1210
1800	72	356	670	2115	2020	1960	44-Φ48	2130	2020	1950	44-Φ56	1280
2000	80	406	760	2325	2230	2170	48-Φ48	2345	2230	2150	48-Φ62	1350

注: 表中H栏尺寸是气动衬氟蝶阀不带手轮机构数据, 若带手轮机构, 需另加手轮高度值

Note: The dimensions in column H in the table refer to the data of the pneumatic fluorine lined butterfly valve without a handwheel mechanism. If a handwheel mechanism is provided, an additional handwheel height value needs to be added

气动衬氟蝶阀ZSHFW-1.0/2.5 K/B

Pneumatic fluorine-lined butterfly valve

F

衬氟阀门系列
Fluorine Lined Valve Series

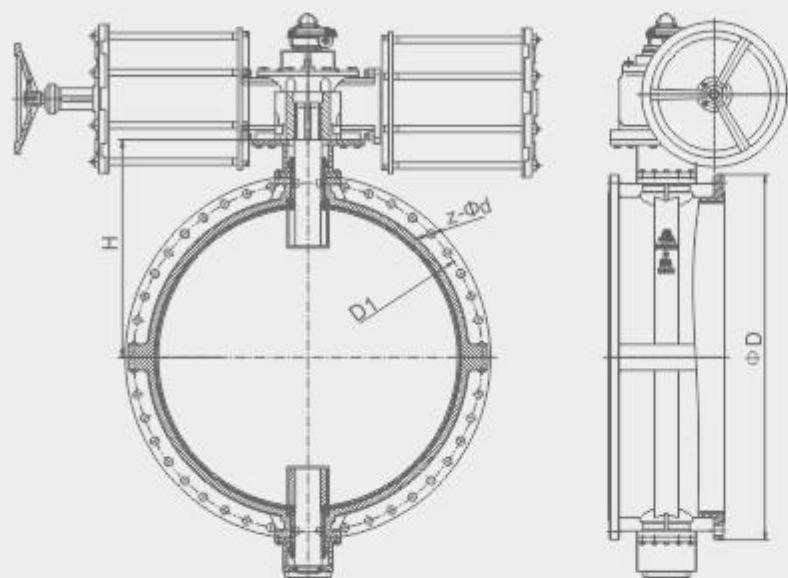

产品标准

设计标准: HG/T3704; GB/T12238
 结构长度: GB/T12221 GB/T15188.2 ASME B16.10
 16.47.A.1HG20623
 法兰标准: GB/T91113.1 JB/T79.1;
 连接方式: 对夹式、法兰式;
 检验标准: GB/T13927 API598;
 驱动方式: 手动 / 电动 / 气动;

Product Standards

Design criteria: HG/T3704; GB/T12238
 Structure length: GB/T12221 GB/T15188.2 ASME B16.10.
 16.47.A.1HG20623
 The flange standard: GB/T91113.1 JB/T79.1;
 Connection mode: wafer, flange;
 Inspection standard: GB/T13927 API598;
 Drive mode: manual/electric/pneumatic;

PN150LB-10K 气动衬氟蝶阀

单位: mm

公称通径 Nominal Diameter		L总长 Total length		美标150LB≥28"为A系列 American standard 150LB ≥ 28" for A series					日标JIS 10K Japanese standard JIS 10K				H	重量 weight (kg)
DN	NPS	对夹 Wafer	法兰 Flange	D	D1	D2	z-Φd	b	D	D1	D2	z-Φd		
40	1 1/2"	33	106	Φ125	Φ98.4	Φ73	4-Φ16	12.7	Φ140	Φ105	Φ73	4-Φ19	145	7.68
50	2"	43	108	Φ150	Φ120.7	Φ92	4-Φ18	14.3	Φ155	Φ120	Φ92	4-Φ19	150	7.68
65	2 1/2"	46	112	Φ180	Φ139.7	Φ105	8-Φ18	15.9	Φ175	Φ140	Φ105	4-Φ19	160	9.65
80	3"	46	114	Φ190	Φ152.4	Φ126	8-Φ18	17.5	Φ185	Φ150	Φ126	8-Φ19	170	10.58
100	4"	52	127	Φ230	Φ190.5	Φ155	8-Φ18	22.3	Φ210	Φ175	Φ155	8-Φ19	185	13.84
125	5"	56	140	Φ255	Φ215.9	Φ185	8-Φ22	22.3	Φ250	Φ210	Φ185	8-Φ23	210	17.88
150	6"	56	140	Φ280	Φ241.3	Φ210	8-Φ22	23.9	Φ280	Φ240	Φ210	8-Φ23	230	22.94
200	8"	60	152	Φ345	Φ298.5	Φ265	8-Φ22	27	Φ330	Φ290	Φ265	12-Φ23	285	39.5
250	10"	68	165	Φ405	Φ362	Φ320	12-Φ26	28.6	Φ400	Φ355	Φ320	12-Φ25	325	53.64
300	12"	78	178	Φ485	Φ431.8	Φ372	12-Φ26	30.2	Φ445	Φ400	Φ372	16-Φ25	360	67.45
350	14"	78	190	Φ535	Φ476.3	Φ432	12-Φ30	33.4	Φ490	Φ445	Φ432	16-Φ25	430	80.01
400	16"	102	216	Φ595	Φ539.8	Φ480	16-Φ30	35	Φ560	Φ510	Φ480	16-Φ27	475	133.29
450	18"	114	222	Φ635	Φ577.9	Φ533	16-Φ33	38.1	Φ620	Φ565	Φ533	20-Φ27	525	146
500	20"	127	229	Φ700	Φ635.0	Φ585	20-Φ33	41.3	Φ675	Φ620	Φ585	20-Φ27	565	203.76
600	24"	154	267	Φ815	Φ749.3	Φ695	20-Φ36	46.1	Φ795	Φ730	Φ695	24-Φ33	620	256
700	28"	165	292	Φ925	Φ863.6	Φ800	28-Φ36	69.9	Φ905	Φ840	Φ800	24-Φ33	686	413
800	32"	190	318	Φ1060	Φ977.7	Φ914	28-Φ42	79.4	Φ1020	Φ950	Φ914	28-Φ33	815	450
900	36"	203	330	Φ1170	Φ1085.8	Φ1022	32-Φ42	88.9	Φ1120	Φ1050	Φ1022	28-Φ33	1010	631
1000	40"	216	410	Φ1290	Φ1200.2	Φ1124	36-Φ42	88.9	Φ1235	Φ1160	Φ1124	28-Φ39	1110	975
1200	48"	254	470	Φ1510	Φ1422.4	Φ1359	44-Φ42	106.4	Φ1465	Φ1380	Φ1359	32-Φ39	1130	1130
1400	56"	279	530	Φ1745	Φ1651	Φ1575	48-Φ48	119.1	-	-	-	-	1210	1980

注: 表中H栏尺寸是气动衬氟蝶阀不带手轮机构数据, 若带手轮机构, 需另加手轮高度值

Note: The dimensions in column H in the table refer to the data of the pneumatic fluorine lined butterfly valve without a handwheel mechanism. If a handwheel mechanism is provided, an additional handwheel height value needs to be added

气动衬氟蝶阀ZSHFW-^{1.0}/_{2.5} K/B

Pneumatic fluorine-lined butterfly valve

五、安装与维修

1. 产品使用的环境温度为 - 30~+70℃.因为执行器活塞的橡胶零件, 在过低温度下易硬化变脆, 高温时会加速老化。
2. 产品最好正立安装。如安装位置不允许, 也可与垂直线成一角度。倾斜安装时, 应考虑加设支承架。
3. 手轮机构使用后, 必须将手动 / 自动操作杆置于自动位置, 否则会影响自动控制。
4. 衬氟蝶阀安装在管道上之前 应彻底清洗管道系统的杂质和污物, 以免阀门运行部件卡死, 或损坏阀座密封面、蝶板密封面等重要零件。
5. 衬氟蝶阀安装时, 密封如有泄漏现象, 需要将上下阀体螺钉重新紧固, 直至无泄漏为止。

六、订货须知

- 1、产品型号
- 2、公称通径DN、公称压力PN
- 3、介质工作压差和工作温度范围
- 4、阀的作用方式: 气关式或气开式
- 5、附件: 电磁阀、阀位反馈器、阀门定位器、手轮机构等
- 6、其它特殊要求
- 7、连接阀兰的执行标准

Installation and maintenance

1. Products using the environment temperature is 30 ~ + 70 °C. Because of the actuator piston rubber parts, easy to hardening of the brittle at low temperatures, high temperature accelerated ageing.
2. The product is best installed. Such as the installation position does not allow, also can with vertical lines into a point of view. When installation, should consider adding support.
3. The handwheel institutions after use, manual/automatic lever must be placed in the automatic position, otherwise it will affect the automatic control.
4. Fluorine-butterfly butterfly valve installed on the pipeline before, should be thoroughly clean impurities and dirt of the pipeline system, so as to avoid the valve stuck running parts, or damage to the valve seat sealing surface, the butterfly plate sealing surface, and other important parts.
5. Fluorine-butterfly butterfly valve installation, seal leakage phenomenon, if any, need will be screws to tighten up and down the body, until no leak.

Ordering instructions

1. Product model
2. Nominal diameter DN, nominal pressure PN
3. Medium working pressure difference and working temperature range
4. The function of the valve: air-closed or air-opened
5. Accessories: solenoid valve, valve position feedback device, valve positioner, handwheel mechanism, etc.
6. Other special requirements
7. The implementation standard of connecting valve flange

国标衬氟球阀 GB Fluorine lined ball valve

结构特点:

Structural features

衬氟球阀是用带圆形通孔的球体作启闭件，球体随阀杆绕阀体中心线旋转以实现阀门开启和关闭。采用特殊的模压工艺，使密封面致密良好，加之V型PTFE填料组合使阀门达到零泄漏；球体与阀杆铸为一体，杜绝了由于压力变化引起阀杆冲出承压件内的可能性，根本保证使用中的安全性；采用氟塑料衬里层的球阀具有极高的化学稳定性，适用于任何强腐蚀性化学介质；采用全通浮动球阀结构，在整个压力范围内进行无泄漏关闭，以便于管路系统在通球扫线和管路维护。

衬氟球阀为控制各种强腐蚀性介质的启闭而进行的专业设计，广泛应用于石油，化工，染化，农药，制酸制碱等行业，是目前防腐阀门最理想的选择。

The fluorine-lined ball valve uses a sphere with a circular through hole as the opening and closing part. The sphere rotates with the valve stem around the center line of the valve body to realize the valve opening and closing. The special molding process is adopted to make the sealing surface dense and good, and the combination of V-shaped PTFE packing makes the valve achieve zero leakage; the ball and the valve stem are cast as a whole, which eliminates the possibility of the valve stem rushing out of the pressure part due to pressure changes. The safety in use is fundamentally guaranteed; the ball valve with fluoroplastic lining layer has extremely high chemical stability and is suitable for any strong corrosive chemical medium; it adopts the structure of all-pass floating ball valve to close the leakage in the entire pressure range. It is convenient for the pipeline system to sweep the line and maintain the pipeline.

The fluorine-lined ball valve is professionally designed to control the opening and closing of various strong corrosive media. It is widely used in petroleum, chemical, dyeing, pesticide, acid and alkali making industries, and is currently the most ideal choice for anti-corrosion valves.

基本型号 Basic model

公称压力PN1.0-2.5(MPa)150Lb公称口径DN15-400(MM)/in1/2"~16"
Nominal pressure PN1.0-2.5 (MPa) 150Lb, nominal diameter DN15-400 (MM)/in1/2"~16"

手 动 Manual	Q41PO(全衬里Fully lined)	蜗 轮 传 动 Worm gear transmission	Q341PO(全衬里Fully lined)	气 动 Pneumatic	Q641PO(全衬里Fully lined)	电 动 Electric	Q941PO(全衬里Fully lined)
	Q41F _{ss} (全衬里Fully lined)		Q341F _{ss} (全衬里Fully lined)		Q641F _{ss} (全衬里Fully lined)		Q941F _{ss} (全衬里Fully lined)
	Q41F _{mon} (全衬里Fully lined)		Q341F _{mon} (全衬里Fully lined)		Q41F _{mon} (全衬里Fully lined)		Q941F _{mon} (全衬里Fully lined)

主要零部件材料表 List of Main Component Materials

序号 NO	零件名称 Name	球磨铸铁 Nodular cast iron	铸钢 Cast steel	不锈钢 Stainless steel		超低碳不锈钢 Ultra low carbon stainless steel	
		Q	C	P	R	RL	RL
1	阀体、阀盖 Valve body, valve cover	QT450-10	WCB	CF8	CF8M	CF3	CF3M
2	球 ball	WCB	WCB	CF8	CF8M	CF3	CF3M
3	衬里层/阀座 Lining layer/valve seat	PFAF(F _{ss})PTFE(F _e)PCTFE(F _{ss})FEP(F _{ss})PFA(可溶F _e)PO(聚烯)					
4	填料压盖 Packing gland	HT250	WCB	CF8	CF8M	CF3	CF3M
5	填料 filler	FPM(聚四氟乙烯Teflon)					
6	螺栓 Bolt	A193 B7	A193 B7	A193 B8	A193 B8	A193 B8	A193 B8
7	螺母 Nut	A194 2H	A194 2H	A194 8M	A194 8M	A194 8M	A194 8M
8	手柄 Handle	WCB					

球阀驱动力矩参考表 Reference table for ball valve driving torque

公称口径 Nominal Diameter	DN	15	20	25	32	40	50	65	80	100	125	150	200	250	300	350	400	450	500	600
	inch	1/2	3/4	1	1 1/4	1 1/2	2	2 1/2	3	4	5	6	8	10	12	14	16	18	20	24
PN6,PN16	N/M	25	25	30	35	50	60	86	120	190	280	580	900	1626	2400	3750	4850	5230	6050	7230
Class150																				
PN25,PN40	N/M	30	30	36	42	55	70	96	132	210	336	630	1140	1951	2880	4500	5820	6276	7260	8676
Class300																				

国标气动衬氟O/V型球阀 ZSHFR/ZSHFV-^{0.6}/_{1.6} K/B

GB Pneumatic furoline-lined ball valve

一. 概述

气动衬氟O型/V型球阀是一种旋转类的防腐控制阀，与流体接触的阀体内壁和金属阀内组件均衬有F46或PFA的防腐材料，除具有可靠的密封性外，几乎能抗所有化学介质（包括浓硝酸和王水）的腐蚀，适用于控制剧毒、贵重、易挥发和易渗透性的介质。球阀配用AT齿轮齿条式活塞执行机构，结构简单，输出力大，成本低，广泛用于化工、石油、冶金、医药、轻纺等工业部门的自动控制系統上，控制强腐蚀性流体。

二. 结构与工作原理

气动衬氟O型/V型球阀是一种防腐的切断或调节控制阀，它由AT活塞执行机构采用齿轮齿条机构，把活塞直线运行转换为旋转运动，驱动球芯旋转90°，实现球阀的开启和关闭。双作用气动衬氟O型球阀是球阀的开启和关闭二位动作都需要气源来实现，单作用气动衬氟O型球阀开启或关闭时，需要气源来实现，同时压缩弹簧，球芯返回时靠弹簧的反作用力把球芯旋转到关闭或开启的位置，气源故障时，可使阀位实现开启或关闭。此外气动衬氟V型球阀采用单作用或双作用活塞执行机构，由定位器控制输出，实现过程调节流量。故称之为调节式球阀。

三. 主要零件材料

阀体、阀盖、填料压盖：WCB、WCC、CF8、CF3、CF&M以及CF3M
球体：WCB、CF8、CF3、CF&M、CF3M
阀杆：2Cr13、304、17-4PH；
密封圈：PTFE；
阀杆填料：PTFE；
推力器缸体：挤压铝（氧化）；
弹簧：60Si2Mn；
活塞：压铸铝（镀镍）；
密封件：橡胶O形圈、NBR

产品特性

设计标准：HG/T3704 GB/T12237 API 608 API6D；
结构长度：GB/T12221 ASME B16.10 HG/T3704；
法兰标准：JB/T79 GB/T9113 HG/T20592 ASME B16.5/47；
连接方式：法兰式；
公称压力：PN0.6~2.5MPa 150Lb~300Lb
检验试验：GB/T13927 API598
驱动方式：手动/电动/气动；

Summary

Pneumatic plastic lined O/V type ball valve is corrosion a rotary type control valve, components in contact with the fluid body wall and the metal valve are lined anticorrosive material with F46 or PFA, has reliable sealing, almost all the chemical medium resistance (including concentrated nitric acid and aqua regia) of corrosion, apply to control toxic, expensive, volatile and easy permeability medium. Ball valve with AT gear rack type piston actuating mechanism, has the advantages of simple structure, large output force, low cost, widely used in automatic control system of chemical industry, petroleum, metallurgy, medicine, textile and other industrial sectors, to control the strong corrosive fluid.

The structure and working principle

Pneumatic plastic lined O/V type ball valve is a kind of anti corrosion off or adjust the control valve, which is composed of AT piston executing agency for the use of a gear rack mechanism, converting piston linear operation to rotary motion, driving the ball core is rotated 90 degrees, the ball valve opening and closing. Double acting pneumatic lining plastic O type ball valve is the valve opening and closing two skill needs gas source to achieve, single acting pneumatic lining plastic O type ball valve open or closed, need air to achieve, at the same time, compression spring, a ball core return on the reaction to the ball core rotation to the spring closed or the open position, the gas supply failure, the valve can be opened or closed. The aerodynamic plastic lining V type ball valve actuator with single or double acting piston, the locator output control, process flow adjustment. It is called a regulating valve.

The major parts material

Body and bonnet,gland:WCB、WCC、CF8、CF3、CF&MandCF3M
Ball:WCB、CF8、CF3、CF&M、CF3M
Stem:2Cr13、304、17-4PH;
Seal: PTFE;
Stem packing: PTFE;
Thruster block: extruded aluminum (oxide);
Spring: 60 si2mn;
Piston: die casting aluminum (nickel plated);
Seal: rubber o-ring, NBR

Product Features

Design standard: HG/T3704 GB/T12237 API 608 API6D;
End-to-end dimension: GB/T12221 ASME B16.10 HG/T3704 ;
Flange standard: JB/T79 GB/T9113 HG/T20592 ASME B16.5/47 ;
Type of connection:Flange connection
Norminal pressure: PN0.6~2.5MPa 150Lb~300Lb
Inspection and testing:GB/T13927 API598
Mode of driving : handle、electrically-driven、air-operated and so on

国标气动衬氟O/V型球阀 ZSHFR/ZSHFV-^{0.6}/_{1.6}/_{2.5}K/B
GB Pneumatic furoline-lined ball valve

F

衬氟阀门系列
Fluorine Lined Valve Series

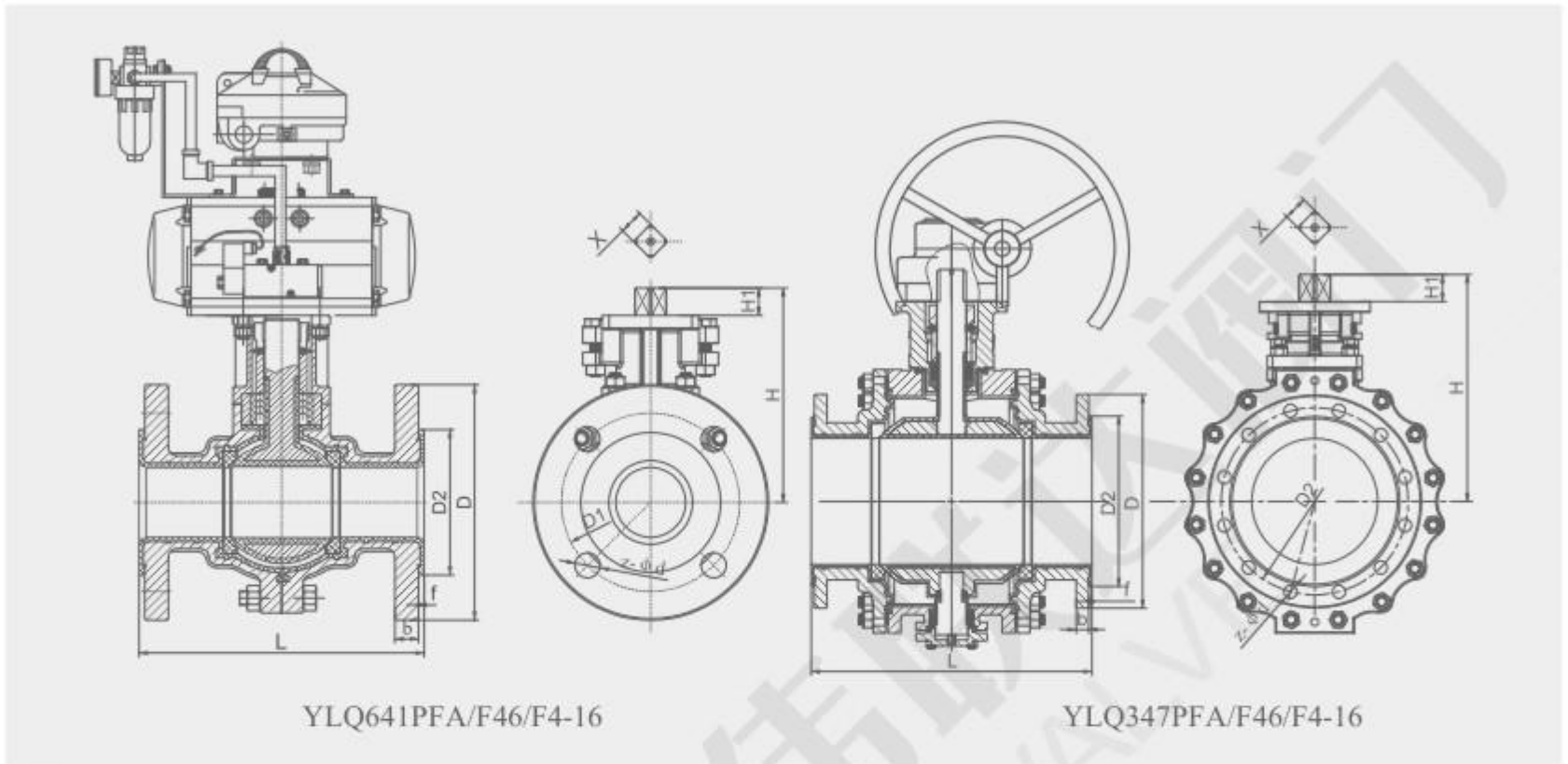

YLQ641PFA/F46/F4-16

YLQ347PFA/F46/F4-16

PN6 国标气动衬氟O/V型球阀

PN6≥DN300为固定球 For fixed ball

DN (mm)	NPS (inch)	L	D	D1	D2	Z-Ød	b	f	ISO	X	H	H1	重量(Kg)
15	1/2"	130	Φ80	Φ55	Φ38	4-Φ11	10	4	F07/F05	14X14	115	17	3.4
20	3/4"	140	Φ90	Φ65	Φ48	4-Φ11	12	4	F07/F05	14X14	115	17	4.2
25	1"	150	Φ100	Φ75	Φ56	4-Φ11	12	4	F07/F05	14X14	120	17	4.9
32	1 1/4"	165	Φ120	Φ90	Φ66	4-Φ14	12	4	F07/F05	14X14	128	17	6.8
40	1 1/2"	180	Φ130	Φ100	Φ76	4-Φ14	12	4	F07/F10	17X17	145	19	9.2
50	2"	200	Φ140	Φ110	Φ86	4-Φ14	12	4	F07/F10	17X17	150	19	10.1
65	2 1/2"	220	Φ160	Φ130	Φ106	4-Φ14	12	4	F10/F12	22X22	187	23	16.8
80	3"	250	Φ190	Φ150	Φ125	4-Φ18	14	4	F10/F12	22X22	200	24	22
100	4"	280	Φ210	Φ170	Φ142	4-Φ18	14	4	F10/F12	22X22	209	24	26.3
125	5"	320	Φ240	Φ200	Φ174	8-Φ18	16	5	F12/F14	27X27	245	28	34.5
150	6"	360	Φ265	Φ225	Φ195	8-Φ18	16	5	F12/F14	27X27	275	31	52
200	8"	400	Φ320	Φ280	Φ255	8-Φ18	18	6	F14/F16	36X36	345	42	106
250	10"	533	Φ375	Φ335	Φ308	12-Φ18	20	6	F16/F20	46X46	428	48	163
300	12"	610	Φ440	Φ395	Φ360	12-Φ22	20	6	F16/F20	46X46	458	48	349
350	14"	686	Φ490	Φ445	Φ410	12-Φ22	20	6	F25/F30	Φ70键2-20	628	77	653
400	16"	762	Φ540	Φ495	Φ460	16-Φ22	20	6	F25/F30	Φ78键2-22	650	115	728
450	18"	864	Φ595	Φ550	Φ518	16-Φ22	20	6	F25/F30	Φ78键2-22	685	105	876
500	20"	914	Φ645	Φ600	Φ570	20-Φ22	22	6	F30/F35	Φ88键2-25	760	120	982
600	24"	1067	Φ755	Φ705	Φ670	20-Φ26	28	6	F30/F35	Φ106键2-28	870	140	1120

注：重量只包括阀本身重量，不含执行机构及附件重量。
Note: The weight only includes the weight of the valve itself, excluding the weight of the actuator and accessories.

国标气动衬氟O/V型球阀 ZSHFR/ZSHFV-^{0.6}/_{1.6}/_{2.5}K/B
GB Pneumatic furoline-lined ball valve

PN10 国标气动衬氟O/V型球阀

PN10≥DN300为固定球 For fixed ball													
DN (mm)	NPS (inch)	L	D	D1	D2	Z-Ød	b	f	ISO	X	H	H1	重量(Kg)
15	1/2"	130	Φ95	Φ65	Φ45	4-Φ14	14	4	F07/F05	14X14	115	17	4.0
20	3/4"	140	Φ105	Φ75	Φ55	4-Φ14	16	4	F07/F05	14X14	115	17	4.7
25	1"	150	Φ115	Φ85	Φ65	4-Φ14	16	4	F07/F05	14X14	120	17	5.5
32	1 1/4"	165	Φ140	Φ100	Φ75	4-Φ18	16	4	F07/F05	14X14	128	17	7.4
40	1 1/2"	180	Φ150	Φ110	Φ85	4-Φ18	16	4	F07/F10	17X17	145	19	10.3
50	2"	200	Φ165	Φ125	Φ96	4-Φ18	16	4	F07/F10	17X17	150	19	11.5
65	2 1/2"	220	Φ185	Φ145	Φ120	8-Φ18	16	4	F10/F12	22X22	187	23	18.4
80	3"	250	Φ200	Φ160	Φ135	8-Φ18	18	4	F10/F12	22X22	200	24	23.3
100	4"	280	Φ220	Φ180	Φ155	8-Φ18	18	4	F10/F12	22X22	209	24	29.4
125	5"	320	Φ250	Φ210	Φ185	8-Φ18	20	5	F12/F14	27X27	245	28	38.8
150	6"	360	Φ285	Φ240	Φ210	8-Φ22	20	5	F12/F14	27X27	275	31	58.3
200	8"	400	Φ340	Φ295	Φ265	8-Φ22	22	6	F14/F16	36X36	345	42	113.5
250	10"	533	Φ395	Φ350	Φ320	12-Φ22	24	6	F16/F20	46X46	428	48	175
300	12"	610	Φ445	Φ400	Φ372	12-Φ22	26	6	F16/F20	46X46	458	48	363
350	14"	686	Φ505	Φ460	Φ432	16-Φ22	28	6	F25/F30	Φ70键2-20	628	77	653
400	16"	762	Φ565	Φ515	Φ480	16-Φ26	30	6	F25/F30	Φ78键2-22	650	115	760
450	18"	864	Φ615	Φ565	Φ518	20-Φ26	26	6	F25/F30	Φ78键2-22	685	105	892
500	20"	914	Φ670	Φ620	Φ570	20-Φ26	26	6	F30/F35	Φ88键2-25	760	120	1005
600	24"	1067	Φ780	Φ725	Φ670	20-Φ30	32	6	F30/F35	Φ106键2-28	870	140	1143

注：重量只包括阀本身重量，不含执行机构及附件重量。
Note: The weight only includes the weight of the valve itself, excluding the weight of the actuator and accessories.

PN16 国标气动衬氟O/V型球阀

PN16≥DN300为固定球 For fixed ball													
DN	NPS	L	D	D1	D2	z-Φd	b	f	ISO	X	H	H1	重量(Kg)
15	1/2"	130	Φ95	Φ65	Φ45	4-Φ14	14	4	F07/F05	14X14	115	17	4.0
20	3/4"	140	Φ105	Φ75	Φ55	4-Φ14	16	4	F07/F05	14X14	115	17	4.7
25	1"	150	Φ115	Φ85	Φ65	4-Φ14	16	4	F07/F05	14X14	120	17	5.5
32	1 1/4"	165	Φ140	Φ100	Φ75	4-Φ18	16	4	F07/F05	14X14	128	17	7.4
40	1 1/2"	180	Φ150	Φ110	Φ85	4-Φ18	16	4	F07/F10	17X17	145	19	10.3
50	2"	200	Φ165	Φ125	Φ96	4-Φ18	16	4	F07/F10	17X17	150	19	11.5
65	2 1/2"	220	Φ185	Φ145	Φ120	8-Φ18	16	4	F10/F12	22X22	187	23	18.4
80	3"	250	Φ200	Φ160	Φ135	8-Φ18	18	4	F10/F12	22X22	200	24	23.3
100	4"	280	Φ220	Φ180	Φ155	8-Φ18	18	4	F10/F12	22X22	209	24	29.4
125	5"	320	Φ250	Φ210	Φ185	8-Φ18	20	5	F12/F14	27X27	245	28	38.8
150	6"	360	Φ285	Φ240	Φ210	8-Φ22	20	5	F12/F14	27X27	275	31	58.3
200	8"	400	Φ340	Φ295	Φ265	12-Φ22	22	6	F14/F16	36X36	345	42	113.5
250	10"	533	Φ405	Φ355	Φ320	12-Φ26	24	6	F16/F20	46X46	428	48	175
300	12"	610	Φ460	Φ410	Φ372	12-Φ26	26	6	F16/F20	46X46	458	48	363
350	14"	686	Φ520	Φ470	Φ432	16-Φ26	28	6	F25/F30	Φ70键2-20	628	77	653
400	16"	762	Φ580	Φ525	Φ480	16-Φ30	30	6	F25/F30	Φ78键2-22	650	115	760
450	18"	864	Φ640	Φ585	Φ545	20-Φ30	38	6	F25/F30	Φ78键2-22	685	105	898
500	20"	914	Φ715	Φ650	Φ605	20-Φ33	42	6	F30/F35	Φ88键2-25	760	120	1035
600	24"	1067	Φ840	Φ770	Φ720	20-Φ36	52	6	F30/F35	Φ106键2-28	870	140	1163

注：重量只包括阀本身重量，不含执行机构及附件重量。
Note: The weight only includes the weight of the valve itself, excluding the weight of the actuator and accessories.

国标气动衬氟O/V型球阀 ZSHFR/ZSHFV-^{0.6}/_{1.6}/_{2.5}K/B

GB Pneumatic furoline-lined ball valve

F

衬氟阀门系列
Fluorine Lined Valve Series

PN25 国标气动衬氟O/V型球阀

PN25≥DN300为固定球 For fixed ball													
DN	NPS	L	D	D1	D2	z-Φd	b	f	ISO	X	H	H1	重量(Kg)
15	1/2"	130	Φ95	Φ65	Φ45	4-Φ14	14	4	F07/F05	14X14	115	17	4.0
20	3/4"	140	Φ105	Φ75	Φ55	4-Φ14	16	4	F07/F05	14X14	115	17	4.7
25	1"	150	Φ115	Φ85	Φ65	4-Φ14	16	4	F07/F05	14X14	120	17	5.5
32	1 1/4"	165	Φ140	Φ100	Φ75	4-Φ18	16	4	F07/F05	14X14	128	17	7.4
40	1 1/2"	180	Φ150	Φ110	Φ85	4-Φ18	16	4	F07/F10	17X17	145	19	10.3
50	2"	200	Φ165	Φ125	Φ96	4-Φ18	18	4	F07/F10	17X17	150	19	11.5
65	2 1/2"	220	Φ185	Φ145	Φ120	8-Φ18	20	4	F10/F12	22X22	187	23	18.4
80	3"	250	Φ200	Φ160	Φ135	8-Φ18	22	4	F10/F12	22X22	200	24	24.3
100	4"	280	Φ235	Φ190	Φ155	8-Φ22	22	4	F10/F12	22X22	209	24	35
125	5"	320	Φ270	Φ220	Φ185	8-Φ26	24	5	F12/F14	27X27	245	28	48.5
150	6"	360	Φ300	Φ250	Φ210	8-Φ26	26	5	F12/F14	27X27	275	31	68.8
200	8"	400	Φ360	Φ310	Φ265	12-Φ26	28	6	F14/F16	36X36	345	42	130
250	10"	533	Φ425	Φ370	Φ320	12-Φ30	30	6	F16/F20	46X46	428	48	190
300	12"	610	Φ485	Φ430	Φ372	16-Φ30	32	6	F16/F20	46X46	458	48	382
350	14"	686	Φ555	Φ490	Φ432	16-Φ33	36	6	F25/F30	Φ70键2-20	628	77	670
400	16"	762	Φ620	Φ550	Φ480	16-Φ36	38	6	F25/F30	Φ78键2-22	650	115	780
450	18"	864	Φ670	Φ600	Φ545	20-Φ36	44	6	F25/F30	Φ78键2-22	685	105	915
500	20"	914	Φ730	Φ660	Φ605	20-Φ36	46	6	F30/F35	Φ88键2-25	760	120	1048
600	24"	1067	Φ845	Φ770	Φ720	20-Φ39	56	6	F30/F35	Φ106键2-28	870	140	1190

注：重量只包括阀本身重量，不含执行机构及附件重量
Note: The weight only includes the weight of the valve itself, excluding the weight of the actuator and accessories.

美标气动衬氟O/V型球阀 ZSHFR/ZSHFV-¹⁵⁰/₃₀₀K/B
Pneumatic furoline-lined ball valve

Class150 气动衬氟O/V型球阀

150LB≥12"为固定球 For fixed ball													
DN	NPS	L	D	D1	D2	z-Φd	b	f	ISO	X	H	H1	重量(KG)
25	1"	127	Φ110	Φ79.4	Φ50.8	4-Φ16	9.6	4	F07/F05	14X14	120	17	5.5
32	1 1/4"	140	Φ115	Φ88.9	Φ63.5	4-Φ16	11.2	4	F07/F05	14X14	128	17	7.4
40	1 1/2"	165	Φ125	Φ98.4	Φ73	4-Φ16	12.7	4	F07/F10	17X17	145	19	10.3
50	2"	178	Φ150	Φ120.7	Φ92	4-Φ18	14.3	4	F07/F10	17X17	150	19	11.5
65	2 1/2"	190	Φ180	Φ139.7	Φ105	4-Φ18	15.9	4	F10/F12	22X22	187	23	18.4
80	3"	203	Φ190	Φ152.4	Φ126	4-Φ18	17.5	4	F10/F12	22X22	200	24	23.3
100	4"	229	Φ230	Φ190.5	Φ155	8-Φ18	22.3	4	F10/F12	22X22	209	24	29.4
125	5"	356	Φ255	Φ215.9	Φ185	8-Φ22	22.3	5	F12/F14	27X27	245	28	38.8
150	6"	394	Φ280	Φ241.3	Φ210	8-Φ22	23.9	5	F12/F14	27X27	275	31	58.3
200	8"	457	Φ345	Φ298.5	Φ265	8-Φ22	27	6	F14/F16	36X36	345	42	113.5
250	10"	533	Φ405	Φ362	Φ320	12-Φ26	28.6	6	F16/F20	46X46	428	48	175
300	12"	610	Φ485	Φ431.8	Φ372	12-Φ26	30.2	6	F16/F20	46X46	458	48	363
350	14"	686	Φ535	Φ476.3	Φ432	12-Φ30	33.4	6	F25/F30	Φ70键2-20	628	77	653
400	16"	762	Φ595	Φ539.8	Φ480	16-Φ30	35	6	F25/F30	Φ78键2-22	650	115	760
450	18"	864	Φ635	Φ577.9	Φ533	16-Φ33	38.1	6	F25/F30	Φ78键2-22	685	105	881
500	20"	914	Φ700	Φ635.0	Φ585	20-Φ33	41.3	6	F30/F35	Φ88键2-25	760	120	1015
600	24"	1067	Φ815	Φ749.3	Φ695	20-Φ36	46.1	6	F30/F35	Φ106键2-28	870	140	1133

Class300 气动衬氟O/V型球阀

300LB≥12"为固定球 For fixed ball													
DN	NPS	L	D	D1	D2	z-Φd	b	f	ISO	X	H	H1	重量(KG)
25	1"	127	Φ125	Φ88.9	Φ50.8	4-Φ18	15.9	4	F07/F05	14X14	120	17	5.5
32	1 1/4"	140	Φ135	Φ98.4	Φ63.5	4-Φ18	17.5	4	F07/F05	14X14	128	17	7.4
40	1 1/2"	165	Φ155	Φ114.3	Φ73	4-Φ22	19.1	4	F07/F10	17X17	145	19	10.3
50	2"	178	Φ165	Φ127	Φ92	8-Φ18	20.7	4	F07/F10	17X17	150	19	11.5
65	2 1/2"	190	Φ190	Φ149.2	Φ105	8-Φ22	23.9	4	F10/F12	22X22	187	23	18.4
80	3"	203	Φ210	Φ168.3	Φ126	8-Φ22	27	4	F10/F12	22X22	200	24	23.3
100	4"	229	Φ255	Φ200	Φ155	8-Φ22	30.2	4	F10/F12	22X22	209	24	29.4
125	5"	356	Φ280	Φ235	Φ185	8-Φ22	33.4	5	F12/F14	27X27	245	28	38.8
150	6"	394	Φ320	Φ269.9	Φ210	12-Φ22	35	5	F12/F14	27X27	275	31	58.3
200	8"	457	Φ380	Φ330.2	Φ265	12-Φ26	39.7	6	F14/F16	36X36	345	42	113.5
250	10"	533	Φ445	Φ387.4	Φ320	16-Φ30	46.1	6	F16/F20	46X46	428	48	175
300	12"	610	Φ520	Φ450.8	Φ372	16-Φ33	49.3	6	F16/F20	46X46	458	48	363
350	14"	686	Φ585	Φ514.4	Φ432	20-Φ33	52.4	6	F25/F30	Φ70键2-20	628	77	653
400	16"	762	Φ650	Φ571.5	Φ480	20-Φ36	55.6	6	F25/F30	Φ78键2-22	650	115	760
450	18"	864	Φ710	Φ628.6	Φ533	24-Φ36	58.8	6	F25/F30	Φ78键2-22	685	105	920
500	20"	914	Φ775	Φ685.8	Φ585	24-Φ36	62	6	F30/F35	Φ88键2-25	760	120	1072
600	24"	1067	Φ915	Φ812.8	Φ695	24-Φ42	68.3	6	F30/F35	Φ106键2-28	870	140	1193

注：重量只包括阀本身重量，不含执行机构及附件重量

Note: The weight only includes the weight of the valve itself, excluding the weight of the actuator and accessories.

气动衬氟O/V型球阀 ZSHFR/ZSHFV-^{0.6}/_{1.6} K/B Pneumatic furoline-lined ball valve

F

衬氟阀门系列
Fluorine Lined Valve Series

五. 安装和调整

Installation and adjustment

1. 一般应整理垂直安装在管道上，自重较大和有震动场合，应加支撑架。
2. 为安全起见，应加旁路管线，以便发生故障或维修时，介质可通过旁路畅流。
3. 球阀安装前，必须把阀体连接的管内污垢和焊渣等物清除干净。阀体内腔杂物也应清除干净。
4. 出厂球阀泄漏量保证达到规定的范围 若使用过程中泄漏量超标，则需要更换阀座。
5. 球阀填料部位，采用上下V型组合填料。使用过程如有渗漏，可拧紧填料压盖的螺母
6. 若球阀转角不符合要求时，可适当调节 AT 执行机构两端的微调螺栓。

1. General should arrange vertically installed in the pipeline, larger weight and vibration applications, should add support frame.
2. For the sake of safety, should be added to the bypass line, fault or repair to, medium can flow through the bypass.
3. Before installing the valve, must be cleaned out the valve connecting pipe dirt and welding slag. The inner cavity of the valve body should also be cleaned.
4. Factory valve leakage is guaranteed to achieve the scope of the provisions, if the use of process leakage amount exceed the standard, you need to replace the seat.
5. Ball valve packing site, using V type composite filler. The use of the process if there is leakage, tighten the packing gland nut
6. If the valve angle does not meet the requirements, the fine tuning bolt can be adjusted at both ends of the AT actuator.

六. 维护和常见故障

Maintenance and the common breakdown

1. 供气源、信号压力一定，但阀门动作不稳定，其主要原因是：供气管线漏气，阀门摩擦力过大，气缸漏气。因此检查供气管线，气缸是否漏气；摩擦力过大，应检查球芯，衬氟层破坏情况
2. 阀门动作迟钝，主要原因是：阀体内有泥浆或粘性过大的介质，出现堵塞或结焦现象，四氟阀座硬化变质。因此，如有上述现象发生，应及时清洗阀体或更换四氟阀座。
3. 阀的泄漏量太大，主要原因是：密封阀座损坏，请更换密封阀座。阀体渗漏，主要原因是：主副阀体间禁锢螺母松弛，应紧固螺母

1. gas source, signal pressure, but the valve action is not stable, the main reason is: the gas pipeline leakage, the valve friction is too large, the gas leakage. So check the gas pipeline, the cylinder leaks; the friction is too large, should check the ball core, lining plastic damage layer
2. the valve action is slow, the main reason is: the valve body with mud or viscous large medium, the blockage or coking phenomenon, PTFE valve seat sclerosis metamorphism. Therefore, if the phenomenon, should be cleaned or replaced PTFE valve seat valve.
3. valve leakage is too large, the main reason is: the sealing seat is damaged, please replace the sealing seat. The valve leakage, main reason is: the main and auxiliary valve body imprisons the nut fastening nut loose, should

六. 订货须知

Ordering instructions

1. 产品型号；
2. 公称通径；
3. 公称压力；
4. 阀体、球芯及内件材质；
5. 介质工作温度范围；
6. 附件；
7. 其它特殊要求。
8. 法兰连接标准

1. model;
2. nominal diameter;
3. the nominal pressure;
4. valve, ball core and inner parts material;
5. medium temperature range;
6. annex;
7. other special requirements.
8. Flange connection standard

衬氟放料阀

Fluorine lined discharge valve

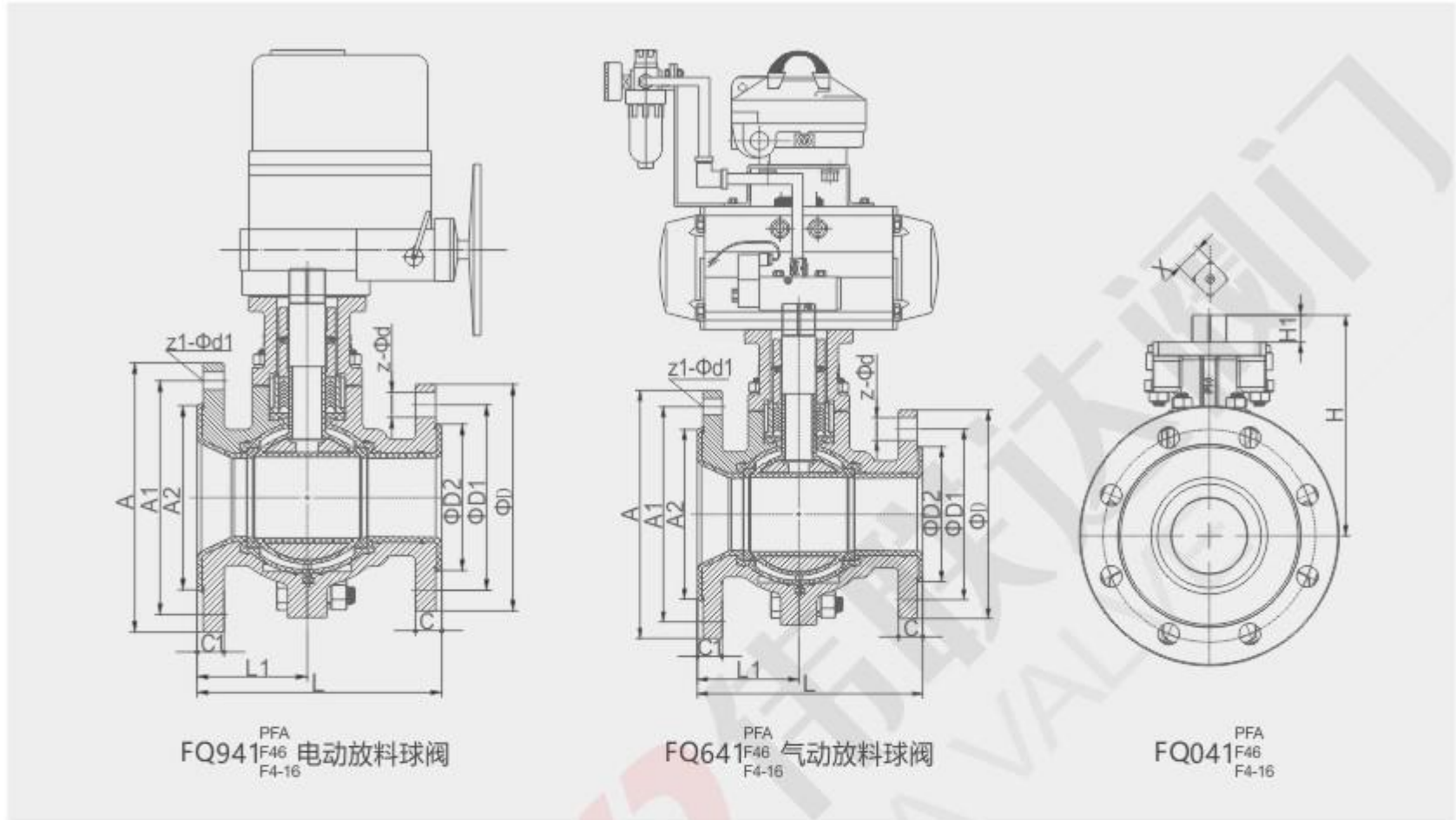

结构特点:

Structural characteristics:

衬氟放料球阀主要用于反应器，储罐和其他容器的底部排料，借助于底部法兰焊接于储罐和其他的底部，因此消除工艺介质通常在容器出口的残留现象。

由本公司自主研发生产的【放料阀】质量可靠、价格合理、售后服务完善。『衬氟放料球阀』适用于各种轻重工业及楼宇管道。优质品质，全球共享！【放料阀】广泛应用于：化工、石化、石油、造纸、采矿、电力、液化气、食品、制药、给排水、市政、机械设备配套、电子工业，城建等领域。

The fluorine lined discharge ball valve is mainly used for the bottom discharge of reactors, storage tanks, and other containers. It is welded to the bottom of the storage tank and other containers with the help of the bottom flange, thus eliminating the residual phenomenon of process media at the outlet of the container.

The 【discharge valve】 independently developed and produced by our company has reliable quality, reasonable price, and perfect after-sales service. The nitrogen lined discharge ball valve is suitable for various light and heavy industries and building pipelines. High quality, shared globally! The discharge valve is widely used in fields such as chemical, petrochemical, petroleum, papermaking, mining, power, liquefied gas, food, pharmaceutical, water supply and drainage, municipal, mechanical equipment supporting, electronic industry, urban construction, etc.

设计标准 Design standards	设计制造规范: GB/T12237 API 608/6D HG/T3704 Design and Manufacturing Specification: GB/T12237 API 608/6D HG/T3704	性能规范 Performance specifications	压力等级: PN1.0~2.5MPa 150Lb~300Lb Pressure rating: PN1.0~2.5MPa 150Lb~300Lb
	结构长度: GB/T12221 ASME B16.10 HG/T3704 Structural length: GB/T12221 ASME B16.10 HG/T3704		强度试验: 1.5MPa Strength test: 1.5MPa
	连接尺寸: GB/T9113 JB/T79 HG/T20592 ASME B16.5 Connection size: GB/T9113 JB/T79 HG/T20592 ASME B16.5		密封试验: 1.1MPa Sealing test: 1.1MPa
	试验与检验: GB/T13927 API 598 Testing and Inspection: GB/T13927 API 598		气密试验: 0.6MPa Air tightness test: 0.6MPa

衬氟放料阀

Fluorine lined discharge valve

F

衬氟阀门系列
Fluorine Lined Valve Series

基本型号 Basic model

公称压力PN1.0-2.5(MPa)150Lb 公称通径DN15-400 (mm)/in1/2"-16"
Nominal pressure PN1.0-2.5 (MPa) 150Lb, nominal diameter DN15-400 (mm)/in1/2 "-16"

手动 Manual	FQ 41PO(全衬里Fully lined)	蜗轮传动 Worm gear transmission	FQ 341PO(全衬里Fully lined)	气动 Pneumatic	FQ 641PO(全衬里Fully lined)	电动 Electric	FQ 941PO(全衬里Fully lined)
	FQ 41F ₄₆ (全衬里Fully lined)		FQ 341F ₄₆ (全衬里Fully lined)		FQ 641F ₄₆ (全衬里Fully lined)		FQ 941F ₄₆ (全衬里Fully lined)
	FQ 41F ₅₀₁ (全衬里Fully lined)		FQ 341F ₅₀₁ (全衬里Fully lined)		FQ 41F ₅₀₁ (全衬里Fully lined)		FQ 941F ₅₀₁ (全衬里Fully lined)

主要零部件材料表 List of Main Component Materials

序号 NO	零件名称 Name	球墨铸铁 Nodular cast iron	铸钢 Cast steel	不锈钢 Stainless steel		超低碳不锈钢 Ultra low carbon stainless steel	
		Q	C	P	R	PL	RL
1	阀体、阀盖 Valve body, valve cover	QT 450-10	WCB	CF8	CF8M	CF3	CF3M
2	球 Ball	WCB	WCB	CF8	CF8M	CF3	CF3M
3	衬里层/阀座 Lining layer/valve seat	PFA(F ₅₀₁)PTFE(F ₄)PCTFE(F ₃)FEP(F ₄₆)PFA(可溶F ₄) PO(聚烯烃)					
4	填料压盖 Packing gland	HT250	WCB	CF8	CF8M	CF3	CF3M
5	填料 Filler	PTFE(F ₄)聚四氟乙烯Teflon					
6	螺栓 Bolt	A193 B7	A193 B7	A193 B8	A193 B8	A193 B8	A193 B8
7	螺母 Nut	A194 2H	A194 2H	A194 8	A194 8	A194 8M	A194 8M
8	手柄 Handle	WCB					

PN16/6 衬氟放料阀

DN	L	L1	D	D1	D2	C	z-Φd	A	A1	A2	C1	z1-Φd1	H	H1	X	ISO
15*25	130	65	Φ95	Φ65	Φ45	18	4-Φ14	Φ100	Φ75	Φ55	18	4-Φ11	115	17	14X14	F05/F07
20*32	140	70	Φ105	Φ75	Φ55	20	4-Φ14	Φ120	Φ90	Φ65	18	4-Φ14	115	17	14X14	F05/F07
25*40	150	75	Φ115	Φ85	Φ65	20	4-Φ14	Φ130	Φ100	Φ75	18	4-Φ14	120	17	14X14	F05/F07
32*50	165	82.5	Φ140	Φ100	Φ75	20	4-Φ18	Φ140	Φ110	Φ82	18	4-Φ14	128	17	14X14	F05/F07
40*65	180	90	Φ150	Φ110	Φ85	20	4-Φ18	Φ160	Φ130	Φ105	18	4-Φ14	145	19	17X17	F05/F10
50*80	178	78	Φ165	Φ125	Φ96	20	4-Φ18	Φ190	Φ150	Φ125	20	4-Φ18	150	19	17X17	F05/F10
65*100	200	90	Φ185	Φ145	Φ120	20	8-Φ18	Φ210	Φ170	Φ145	20	4-Φ18	187	23	22X22	F10/F12
80*125	220	96	Φ200	Φ160	Φ135	22	8-Φ18	Φ240	Φ200	Φ175	22	8-Φ18	200	24	22X22	F10/F12
100*150	241	102	Φ220	Φ180	Φ155	22	8-Φ18	Φ265	Φ225	Φ190	22	8-Φ18	209	24	22X22	F10/F12

衬氟上/下展式放料阀

Fluorine lined up/down discharge valve

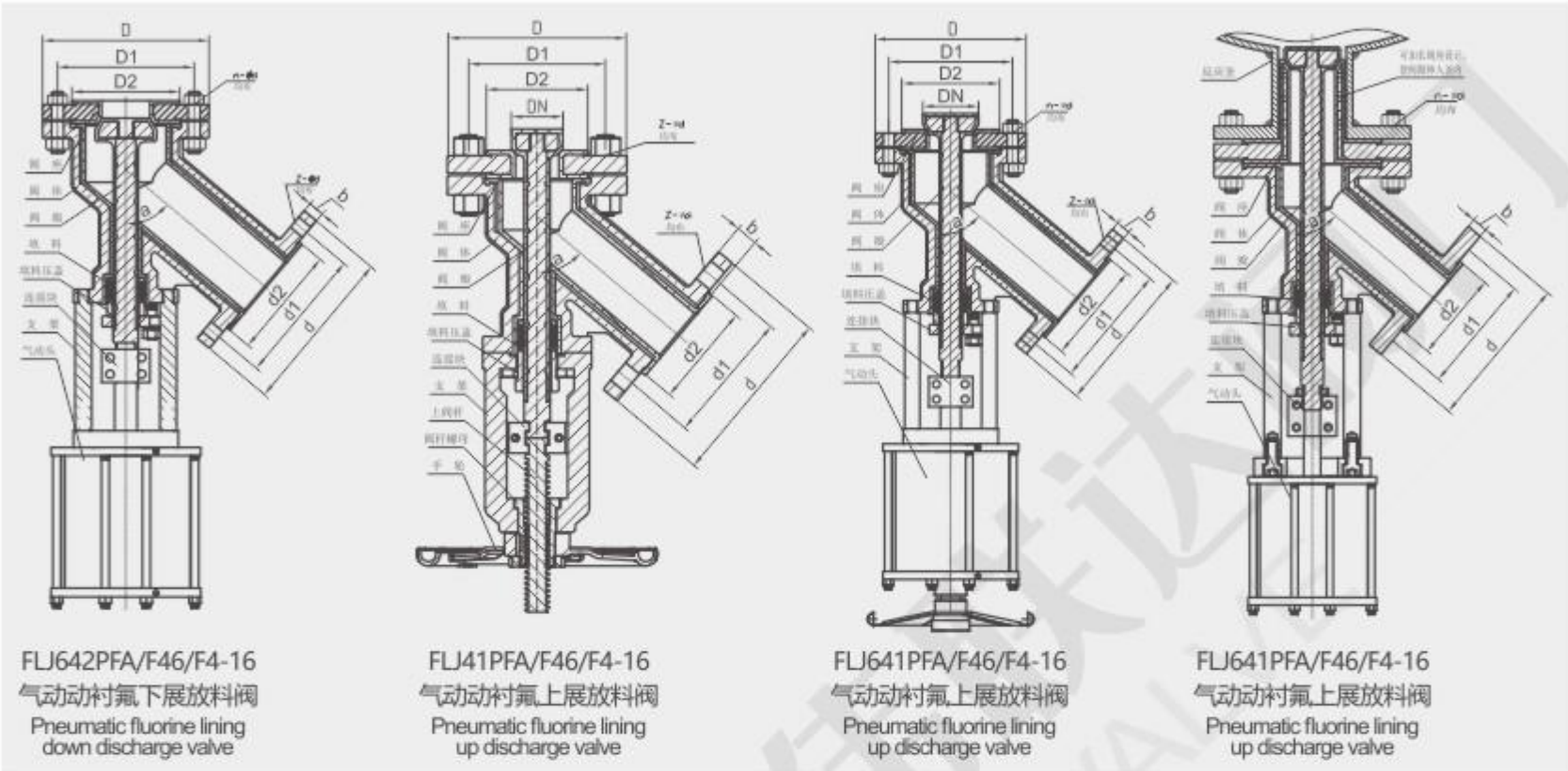

感谢您选用本公司上展放料阀。阀门作为承压设备的一类，具有潜在的压力危害和因流体的泄漏而产生的爆炸性气体。从安全的角度出发，用户在使用前应阅读本说明书。

Thank you for choosing our company's upward discharge valve. As a type of pressure equipment, valves have potential pressure hazards and explosive gases generated due to fluid leakage. From a safety perspective, users should read this manual before use.

用户注意事项

Structural characteristics:

- 1、在任何情况下，首先保障人的安全。
- 2、应根据GB/T12224的压力-温度等级使用此阀门。
- 3、应保证所选材质能抵抗流体的腐蚀或磨损。
- 4、当流体为易燃易爆时，应限制工作温度。
- 5、在维修/保养过程中，应保证阀门处在卸压和排污排空状态。
- 6、对于动力驱动阀门，在任何操作前应保证动力系统（电、液、气）断开。
- 7、在维修/保养过程中，应采用适当防护，如防护服、氧气罩、手套等。
- 8、在维修/保养过程的现场，不能吸烟，不要用非防爆式电动装置，未经许可不能用明火。
- 9、阀门必须定期检查：
 - 螺栓/母连接是否紧固（体/盖、压板、法兰连接）
 - 腐蚀/磨损危害（撞击、点蚀、厚度的减小）
 - 弄清阀门是处于全开/全关位置

The fluorine lined discharge ball valve is mainly used for the bottom discharge of reactors, storage tanks, and other containers. It is welded to the bottom of the storage tank and other containers with the help of the bottom flange, thus eliminating the residual phenomenon of process media at the outlet of the container.

The 【discharge valve】 independently developed and produced by our company has reliable quality, reasonable price, and perfect after-sales service. The nitrogen lined discharge ball valve is suitable for various light and heavy industries and building pipelines. High quality, shared globally! The discharge valve is widely used in fields such as chemical, petrochemical, petroleum, papermaking, mining, power, liquefied gas, food, pharmaceutical, water supply and drainage, municipal, mechanical equipment supporting, electronic industry, urban construction, etc.

适用场合及选用原则

Applicable occasions and selection principles

衬氟上展放料阀主要用于储料罐、反应釜及其他容器的底部排放物料，阀瓣随阀杆的升降开启和关闭。采用特殊的模压工艺，使密封面致密良好，加之V型PTFE填料组合使阀门达到零泄漏；采用全塑料衬里工艺，耐介质的强腐蚀。现广泛用于化工、石油、冶金、医药等工业部门，实现对生产过程中强酸、强碱等强腐蚀介质的调节或切断，适用温度： $\leq 120^{\circ}\text{C}$ 、 $\leq 150^{\circ}\text{C}$ 、 $\leq 180^{\circ}\text{C}$ （按照衬里材料）

The fluorine lined upward discharge valve is mainly used for discharging materials from the bottom of storage tanks, reaction kettles, and other containers. The valve disc opens and closes with the rise and fall of the valve stem. Adopting a special molding process to make the sealing surface dense and good, combined with V-shaped PTFE packing, the valve achieves zero leakage; Adopting a fully plastic lining process, it is resistant to strong corrosion of the medium. It is widely used in industrial sectors such as chemical, petroleum, metallurgy, pharmaceuticals, etc. to regulate or cut off strong corrosive media such as strong acids and alkalis during the production process. Applicable temperatures: $\leq 120^{\circ}\text{C}$, $\leq 150^{\circ}\text{C}$, $\leq 180^{\circ}\text{C}$ (according to lining materials)

衬氟上/下展式放料阀

Fluorine lined up/down discharge valve

F

衬氟阀门系列
Fluorine Lined Valve Series

设计标准
Design standards

设计制造规范: HG/T3704G&B/T12237
Design and Manufacturing Specification: HG/T3704G&B/T12237

法兰连接尺寸: HG/T20592&GB/T9113
Flange connection size: HG/T20592&GB/T9113

结构长度: JB/T 11489-2013
Structural length: JB/T 11489-2013

试验与检验: GB/T13927 (阀门的衬里需进行高频电火花检验)
Testing and inspection: GB/T13927 (High frequency electric spark inspection is required for the lining of valves)

工作原理

Working principle

阀门为上展式放料阀,内衬氟塑料。阀瓣与阀杆融为一体,密封性能好,安全可靠。其动作和密封原理:通过手轮或气动执行器带动阀杆升降,阀瓣与阀杆是整体结构,所以阀瓣也随之转动,达到开启与关闭之目的。上升距离由专用限位开关控制。阀瓣与阀座为紧密密封结合,具备零泄漏功能,并能利用其塑性变形自动补偿因磨损带来的误差,达到密封性能好,使用寿命长的目的。为了保证阀杆处的密封,在阀杆处增设了V形填料组和压盖进行密封。在阀盖的上部还设计了便于安装电动、气动装置的平台。确保安装使用的安全、可靠性。

The valve is an upward expansion discharge valve, lined with fluoroplastic. The valve disc and valve stem are integrated, with good sealing performance and safety and reliability. Its action and sealing principle: The valve stem is driven up and down by a handwheel or pneumatic actuator. The valve disc and valve stem are integral structures, so the valve disc also rotates to achieve the purpose of opening and closing. The lifting distance is controlled by a dedicated limit switch. The valve disc and valve seat are tightly sealed, with zero leakage function, and can use their plastic deformation to automatically compensate for errors caused by wear, achieving good sealing performance and long service life. In order to ensure the sealing at the valve stem, a V-shaped packing group and a gland are added at the valve stem for sealing. A platform is also designed on the upper part of the valve cover for easy installation of electric and pneumatic devices. Ensure the safety and reliability of installation and use.

上展放料阀的特点

Characteristics of the upward discharge valve

- 1、阀门可在整个压力范围内进行无泄漏关闭,更便于管路系统的通球扫线和管路维护
- 2、启闭件阀瓣与阀杆为一体,杜绝了由于压力变化引起阀杆冲出承压件内的可能性,从根本上保证了工程中的使用安全性
- 3、结构简单、操作方便、开启自由、运动灵活可靠,阀体采用V形结构,减小了介质滞留,另外,特殊的模压工艺,使密封面致密度良好,加之人字环形PTFE填料组合,使阀门达到零泄漏性能:介质工作温度: -29℃~150℃

1. The valve can be closed without leakage within the whole pressure range, which is more convenient for ball sweeping and pipeline maintenance of Plumbing
 2. The valve disc and valve stem of the opening and closing parts are integrated, eliminating the possibility of the valve stem rushing out of the pressure bearing parts due to pressure changes, fundamentally ensuring the safety of use in engineering
 3. Simple structure, easy operation, free opening, flexible and reliable movement. The valve body adopts a V-shaped structure to reduce medium retention. In addition, the special molding process ensures good density of the sealing surface. In addition, the combination of herringbone ring PTFE packing ensures zero leakage of the valve
- Performance: Medium working temperature: -29℃~150℃

主要零件材料

Material for main parts

零件名称 Part Name	材料 Material
阀体、阀座 Valve body, valve seat	WCB+氟塑料、CF8+氟塑料、CF3+氟塑料、CF8M+氟塑料、CF3M+氟塑料 WCB+fluoroplastics, CF8+fluoroplastics, CF3+fluoroplastics, CF8M+fluoroplastics, CF3M+fluoroplastics
阀瓣 Valve disc	WCB+氟塑料、CF8+氟塑料、CF3+氟塑料、CF8M+氟塑料、CF3M+氟塑料 WCB+fluoroplastics, CF8+fluoroplastics, CF3+fluoroplastics, CF8M+fluoroplastics, CF3M+fluoroplastics
氟塑料 Fluoroplastics	PTFE、FEP、PFA
填料 filler	RPTFE

衬里材质分类

Classification of lining materials

结构优点

Classification of lining materials

1.本产品密封方式为软密封结构,密封结构合理,可以做到零泄漏的标准,适用于各种工业生产中液体放料,特别在稀酸、浓酸等介质中均能很好地工作。

1. The sealing method of this product is a soft sealing structure, which is reasonable and can achieve zero leakage standards. It is suitable for liquid discharge in various industrial production, especially in dilute acid, concentrated acid and other media, and can work well.

2.活载填料

阀门采用低泄漏多层V形填料设计,解决自控阀频繁开启时的填料滴漏问题。

2. Live load filler

The valve adopts a low leakage multi-layer V-shaped packing design to solve the problem of packing leakage when the automatic control valve is frequently opened.

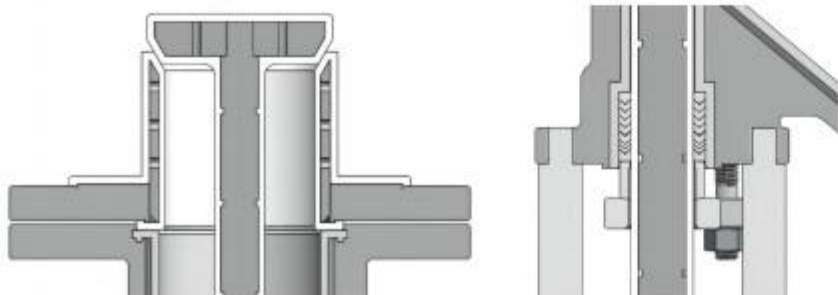

衬氟上/下展式放料阀

Fluorine lined up/down discharge valve

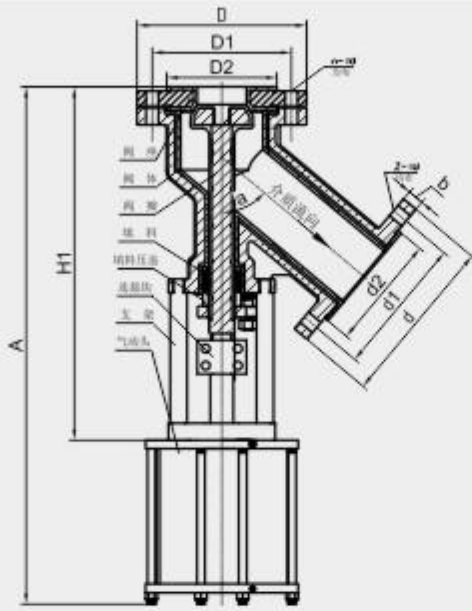

FLJ642PFA/F46/F4-16

气动衬氟下展放料阀

Pneumatic fluorine lining down discharge valve

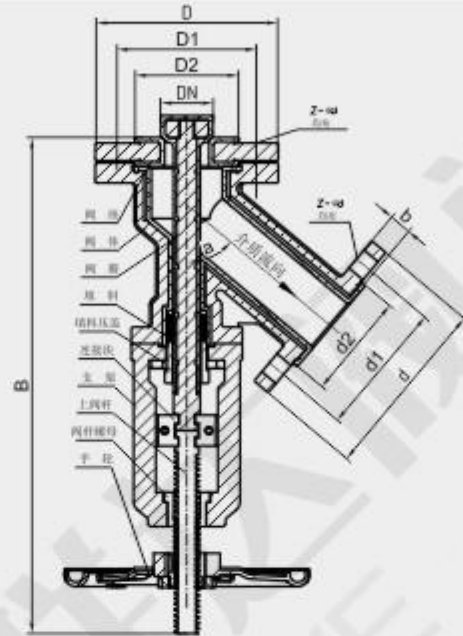

FLJ41PFA/F46/F4-16

气动衬氟上展放料阀

Pneumatic fluorine lining up discharge valve

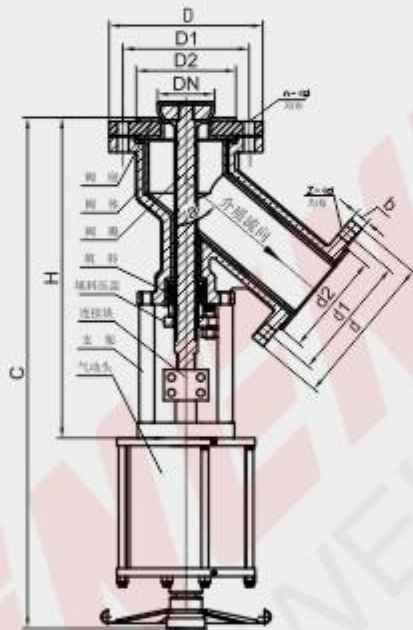

FLJ641PFA/F46/F4-16

气动衬氟上展放料阀

Pneumatic fluorine lining up discharge valve

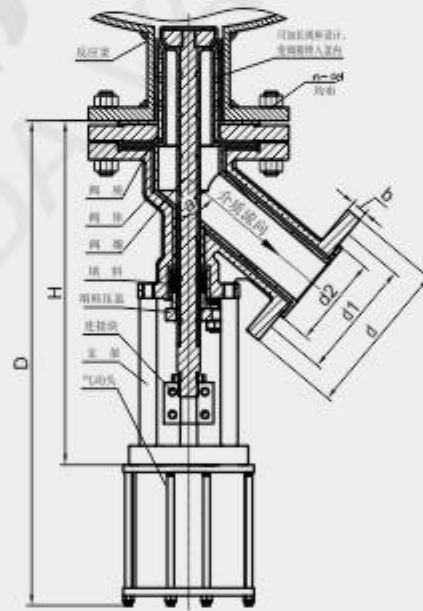

FLJ641PFA/F46/F4-16

气动衬氟上展放料阀

Pneumatic fluorine lining up discharge valve

PN16 衬氟上/下展式放料阀

DN	D	D1	D2	n-Φd	d	d1	d2	b	Z-Φd	a°	行程 Trip	重量 KG Weight	A	B	C	D	H	H1
40	Φ150	Φ110	Φ85	4-Φ18	Φ150	Φ110	Φ85	18	4-Φ18	50°	30	15.5	645	480	875	615	400	430
50	Φ165	Φ125	Φ96	4-Φ18	Φ165	Φ125	Φ96	18	4-Φ18	50°	30	16.2	645	480	875	615	400	430
65	Φ185	Φ145	Φ120	8-Φ18	Φ185	Φ145	Φ120	18	8-Φ18	50°	40	19.5	667	510	900	640	420	450
80	Φ200	Φ160	Φ135	8-Φ18	Φ200	Φ160	Φ135	20	8-Φ18	50°	40	31.8	865	580	1000	740	490	520
100	Φ220	Φ180	Φ155	8-Φ18	Φ220	Φ180	Φ155	20	8-Φ18	60°	60	37.3	1030	600	1010	750	500	530
125	Φ250	Φ210	Φ185	8-Φ18	Φ250	Φ210	Φ185	22	8-Φ18	60°	60	45	1030	600	1010	750	500	530
150	Φ285	Φ240	Φ210	8-Φ22	Φ285	Φ240	Φ210	22	8-Φ22	60°	70	61.7	1110	710	1200	950	550	650
200	Φ340	Φ295	Φ265	12-Φ22	Φ340	Φ295	Φ265	24	12-Φ22	60°	85	90.6	1240	890	1380	1090	690	750

重量不包含执行器，高度按单作用执行器，如执行器有改运请致电永联咨询
进口法兰与阀座直径，高度可按客户釜底法兰定做，详情请致电永联咨询

三通衬氟球阀

Three-way fluorine-lined ball valve

F

衬氟阀门系列
Fluorine Lined Valve Series

一、概述

三通衬氟球阀是，是一种旋转类切断调节阀门，具有关闭严密，结构紧凑，重量轻，维修方便等优点。广泛用于气体、液体、蒸汽、油品等腐蚀性介质的管道自动化控制中。具有结构紧凑、外型美观、密封性能好。能实现对管道中介质流向的切换。也能使相互垂直的两个通道连通或关闭。四阀座密封三通球阀具有造型美观、结构紧凑合理。通过不同的球体(T形球体/L形球体)不仅可实现介质流向的切换，也可使三个通道相互连通，现时也可关闭任一通道，使另外两个通道连通，灵活控制管路中介质的合流或分流。故称之为三通换向球阀。

Summary

The three-way fluorine-lined ball valve is a kind of rotary cut-off regulating valve, which has the advantages of tight closing, compact structure, light weight and convenient maintenance. It is widely used in pipeline automation control of corrosive media such as gas, liquid, steam and oil. It has compact structure, beautiful appearance and good sealing performance. It can realize the switching of the flow direction of the medium in the pipeline. It is also possible to connect or close two channels that are perpendicular to each other. The four-seat sealed three-way ball valve has beautiful appearance, compact and reasonable structure. Through different spheres (T-shaped sphere/L-shaped sphere), not only can the medium flow direction be switched, but also the three channels can be connected to each other. Confluence or diversion of media. Therefore, it is called a three-way reversing ball valve.

二、T型流向示意图

T-shaped flow diagram

A向入口
Entrance to A

90° 旋转方向
90° Direction of rotation

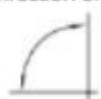

90° 旋转方向
90° Direction of rotation

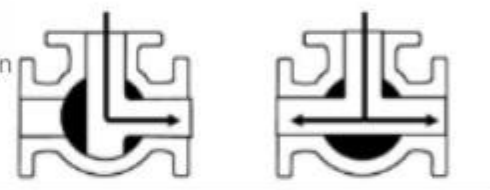

B向入口向
Entrance to B

90° 旋转方
90° Direction of rotation

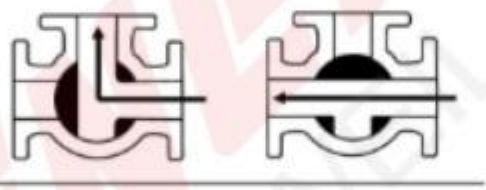

90° 旋转方向
90° Direction of rotation

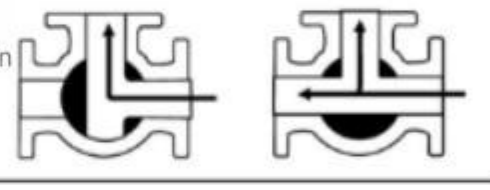

C向入口
Entrance to C

90° 旋转方向
90° Direction of rotation

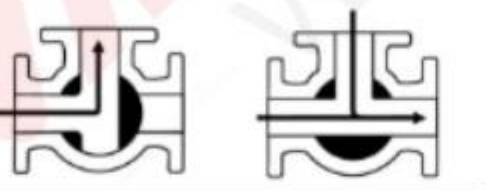

90° 旋转方向
90° Direction of rotation

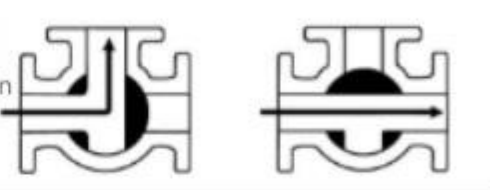

三、L型流向示意图

L-shaped flow diagram

A向入口
Entrance to A

90° 旋转方向
90° Direction of rotation

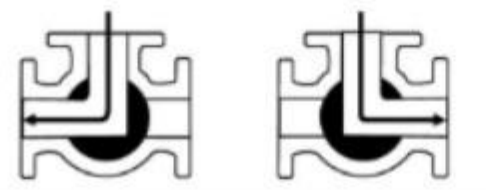

C向、B向切换入口
Switch-over Entrance of C and B

90° 旋转方向
90° Direction of rotation

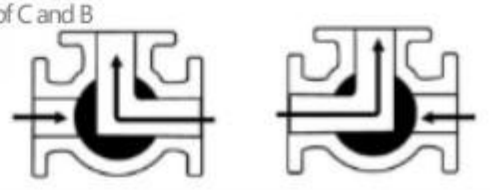

国标三通球阀

GB Three-way ball valve

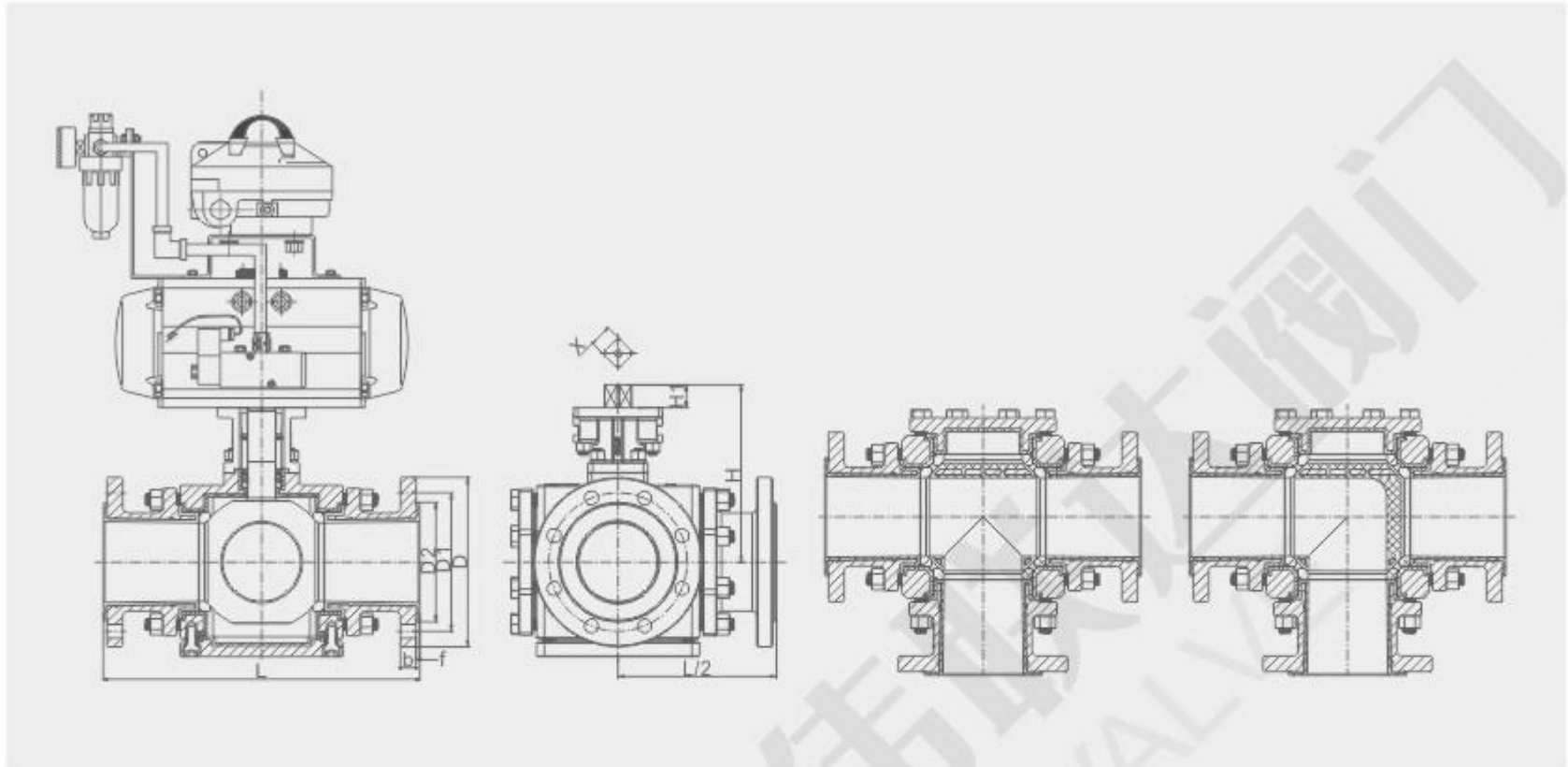

PN10 全通径

DN	NPS	L	L1	D	D1	D2	z-Φd	b	f	ISO	X	H	H1	重量(KG)
15	1/2"	210	105	Φ95	Φ65	Φ45	4-Φ14	14	4	F07/F05	14X14	118	15	7.3
20	3/4"	210	105	Φ105	Φ75	Φ55	4-Φ14	16	4	F07/F05	14X14	118	15	8
25	1"	220	110	Φ115	Φ85	Φ65	4-Φ14	16	4	F07/F05	14X14	124	16	9.9
32	1 1/4"	220	110	Φ140	Φ100	Φ75	4-Φ18	16	4	F07/F05	14X14	124	16	11.6
40	1 1/2"	240	120	Φ150	Φ110	Φ85	4-Φ18	16	4	F07/F10	17X17	145	19	22.3
50	2"	250	120	Φ165	Φ125	Φ96	4-Φ18	16	4	F07/F10	17X17	150	19	28.5
65	2 1/2"	350	175	Φ185	Φ145	Φ120	8-Φ18	16	4	F10/F12	22X22	180	24	41.3
80	3"	370	185	Φ200	Φ160	Φ135	8-Φ18	18	4	F10/F12	22X22	180	24	44.7
100	4"	410	205	Φ220	Φ180	Φ155	8-Φ18	18	4	F10/F12	27X27	230.5	30	70.4
125	5"	450	225	Φ250	Φ210	Φ185	8-Φ18	20	5	F10/F12	27X27	242	30	97.4
150	6"	470	235	Φ285	Φ240	Φ210	8-Φ22	20	5	F12/F14	27X27	242	30	104.3
200	8"	550	275	Φ340	Φ295	Φ265	8-Φ22	22	6	F14/F16	36X36	345	42	198
250	10"	550	275	Φ395	Φ350	Φ320	12-Φ22	24	6	F16/F20	46X46	428	48	265

注：重量只包括阀本身重量，不含执行机构及附件重量

Note: The weight only includes the weight of the valve itself, excluding the weight of the actuator and accessories

国标/美标三通球阀
GB/ANSI Three-way ball valve

F

衬氟阀门系列
Fluorine Lined Valve Series

PN16 全通径

DN	NPS	L	L1	D	D1	D2	z-Φd	b	f	ISO	X	H	H1	重量(KG)
15	1/2"	210	105	Φ95	Φ65	Φ45	4-Φ14	14	4	F07/F05	14X14	118	15	7.3
20	3/4"	210	105	Φ105	Φ75	Φ55	4-Φ14	16	4	F07/F05	14X14	118	15	8
25	1"	220	110	Φ115	Φ85	Φ65	4-Φ14	16	4	F07/F05	14X14	124	16	9.9
32	1 1/4"	220	110	Φ140	Φ100	Φ75	4-Φ18	16	4	F07/F05	14X14	124	16	11.6
40	1 1/2"	240	120	Φ150	Φ110	Φ85	4-Φ18	16	4	F07/F10	17X17	145	19	22.3
50	2"	240	120	Φ165	Φ125	Φ96	4-Φ18	16	4	F07/F10	17X17	150	19	28.5
65	2 1/2"	350	175	Φ185	Φ145	Φ120	8-Φ18	16	4	F10/F12	22X22	180	24	41.3
80	3"	370	185	Φ200	Φ160	Φ135	8-Φ18	18	4	F10/F12	22X22	180	24	44.7
100	4"	410	205	Φ220	Φ180	Φ155	8-Φ18	18	4	F10/F12	27X27	230.5	30	70.4
125	5"	450	225	Φ250	Φ210	Φ185	8-Φ18	20	5	F10/F12	27X27	242	30	97.4
150	6"	470	235	Φ285	Φ240	Φ210	8-Φ22	20	5	F12/F14	27X27	242	30	104.3
200	8"	550	275	Φ340	Φ295	Φ265	12-Φ22	20	6	F14/F16	36X36	345	42	198
250	10"	550	275	Φ405	Φ355	Φ320	12-Φ26	22	6	F16/F20	46X46	428	48	265

注：重量只包括阀本身重量，不含执行机构及附件重量
Note: The weight only includes the weight of the valve itself, excluding the weight of the actuator and accessories

Class150 全通径

DN	NPS	L	L1	D	D1	D2	z-Φd	b	f	ISO	X	H	H1	重量(KG)
15	1/2"	210	105	Φ90	Φ60.3	Φ45	4-Φ16	8	4	F07/F05	14X14	118	15	7.3
20	3/4"	210	105	Φ100	Φ69.9	Φ55	4-Φ16	8.9	4	F07/F05	14X14	118	15	8
25	1"	220	110	Φ110	Φ79.4	Φ65	4-Φ16	9.6	4	F07/F05	14X14	124	16	9.9
32	1 1/4"	220	110	Φ115	Φ88.9	Φ75	4-Φ16	11.2	4	F07/F05	14X14	124	16	11.6
40	1 1/2"	240	120	Φ125	Φ98.4	Φ85	4-Φ16	12.7	4	F07/F10	17X17	145	19	22.3
50	2"	240	120	Φ150	Φ120.7	Φ96	4-Φ19	14.3	4	F07/F10	17X17	150	19	28.5
65	2 1/2"	350	175	Φ180	Φ139.7	Φ120	4-Φ19	15.9	4	F10/F12	22X22	180	24	41.3
80	3"	370	185	Φ190	Φ152.4	Φ135	4-Φ19	17.5	4	F10/F12	22X22	180	24	44.7
100	4"	410	205	Φ230	Φ190.5	Φ155	8-Φ19	22.3	4	F10/F12	27X27	230.5	30	70.4
125	5"	450	225	Φ255	Φ215.9	Φ185	8-Φ22.5	22.3	5	F10/F12	27X27	242	30	97.4
150	6"	470	235	Φ280	Φ241.3	Φ210	8-Φ22.5	23.9	5	F12/F14	27X27	242	30	104.3
200	8"	550	275	Φ345	Φ298.5	Φ265	8-Φ22.5	27	6	F14/F16	36X36	345	42	198
250	10"	550	275	Φ405	Φ362	Φ320	12-Φ26	28.6	6	F16/F20	46X46	428	48	265

注：重量只包括阀本身重量，不含执行机构及附件重量
Note: The weight only includes the weight of the valve itself, excluding the weight of the actuator and accessories

衬氟闸阀

Fluorine lined gate valve

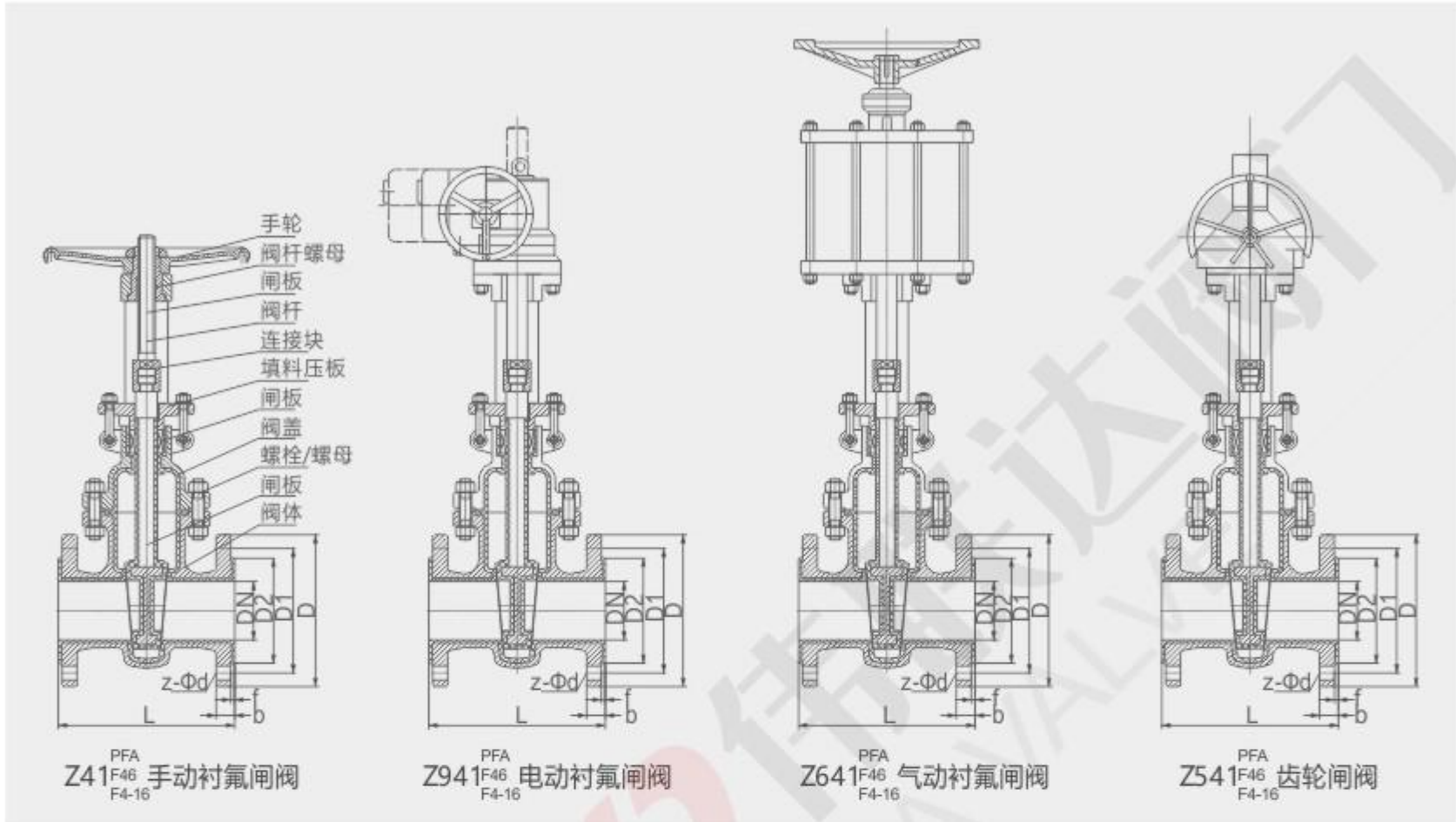

结构特点:

衬氟闸阀是阀门的一种。衬氟闸阀的启闭件是闸板，闸板的运动方向与流体方向相垂直，闸阀只能作全开和全关，不能作调节和节流。

闸板有两个密封面，最常用的模式闸板阀的两个密封面形成楔形，楔形角随阀门参数而异，通常为5°，介质温度不高时为2°52'。

模式闸阀的闸板可以做成一个整体，叫做刚性闸板；也可以做成能产生微量变形的闸板，以改善其工艺性，弥补密封面角度在加工过程中产生的偏差，这种闸板叫做弹性闸板。

本系列产品具有以下特点：

- 1、流体阻力小，密封面受介质的冲刷和侵蚀小。
- 2、开闭较省力。
- 3、介质流向不受限制，不扰流、不降低压力。
- 4、形体简单，结构长度短，制造工艺性好，适用范围广。

Structural characteristics:

Fluorine lined gate valve is a type of valve. The opening and closing component of the fluorine lined gate valve is the gate, and the movement direction of the gate is perpendicular to the direction of the fluid. The gate valve can only be fully open and fully closed, and cannot be adjusted or throttled.

There are two gate sealing surface, the most common mode of gate valve sealing surface to form two wedge, wedge angle varies with the valve parameters, usually 5°, medium is not high temperature is 2°52'.

Wedge gate valve can be made into a whole, called the rigid gate; also be made to produce small deformation of the gate, in order to improve its process, make up the sealing surface angle deviations arising during processing, this gate is called the flexible gate.

This series of products have the following characteristics:

1. small fluid resistance, the sealing surface by erosion Chong brush medium and small.
2. open and close more effort.
3. media flow unrestricted, non spoiler, do not reduce the pressure.
4. form a simple structure, short length, good manufacturing process, applicable to a wide range of.

设计标准
Design standards

设计制造规范: GB/T12234 API600
Design and Manufacturing Specification: GB/T12234 API600

结构长度: GB/T12221 ASME B16.10
Structural length: GB/T12221 ASME B16.10

连接尺寸: GB/T9113 JB/T79 HG/T20592 ASME B16.5
Connection size: GB/T9113 JB/T79 HG/T20592 ASME B16.5

试验与检验: GB/T13927 API 598
Testing and Inspection: GB/T13927 API 598

性能规范
Performance specifications

压力等级: PN0.6~1.6MPa 150Lb
Pressure rating: PN0.6~1.6MPa 150Lb

强度试验: 1.5MPa
Strength test: 1.5MPa

密封试验: 1.1MPa
Sealing test: 1.1MPa

气密试验: 0.6MPa
Air tightness test: 0.6MPa

衬氟闸阀

Fluorine lined gate valve

F

衬氟阀门系列
Fluorine Lined Valve Series

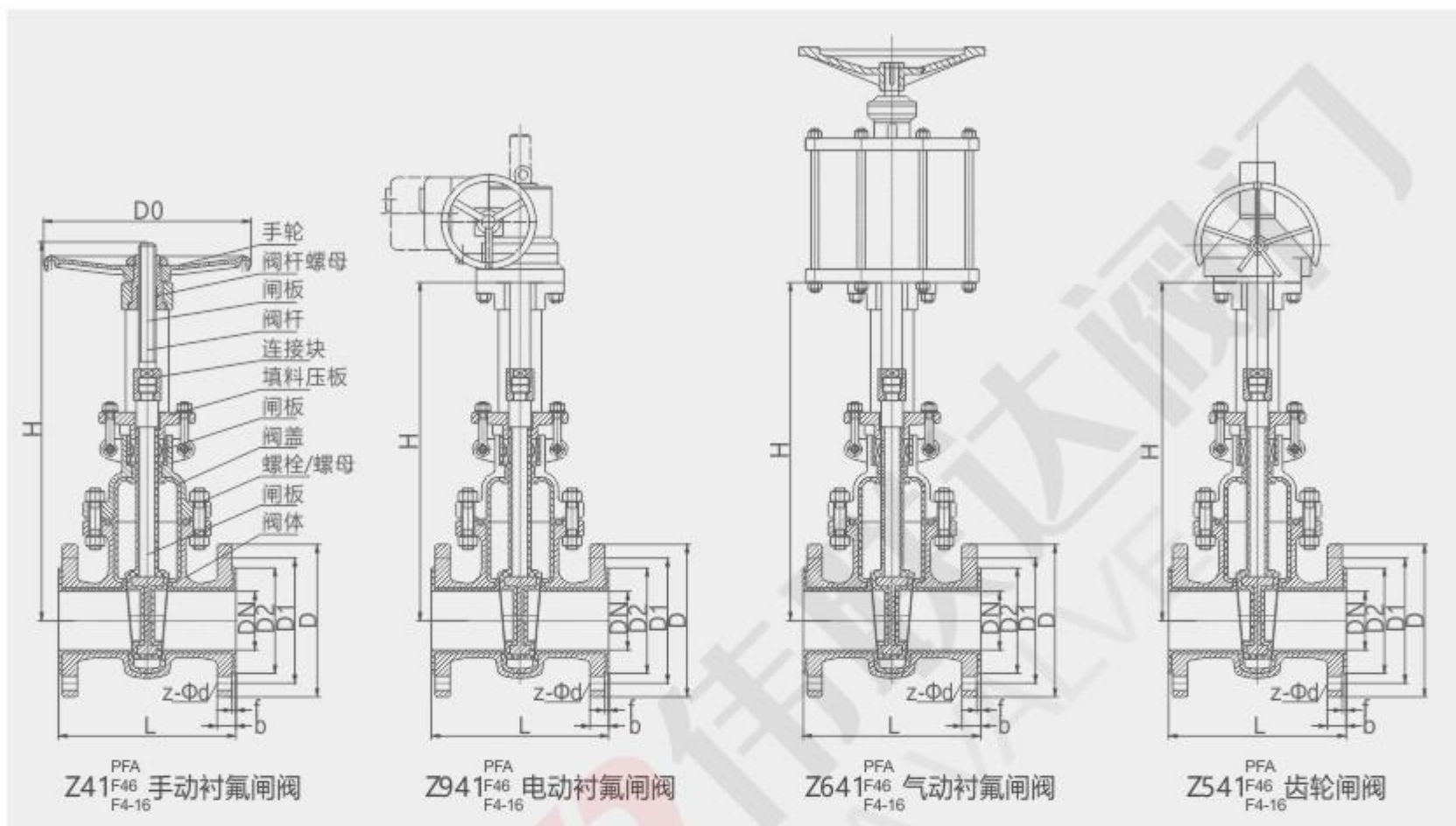

产品特性

设计标准: GB/T12234 API 600;
结构长度: GB/T12221 ASME B16. 10;
法兰标准: JB/T79 GB/T9113 HG/T20592 ASME B16. 5/47;
公称压力: PN 0. 6~2.5MPa 150Lb~300Lb
检验试验: GB/T13927 API598
驱动方式: 手动 / 电动 / 气动;

Product Features

Design standard: GB/T12234 API 600;
End-to-end dimension: GB/T12221 ASME B16. 10 HG/T3704;
Flange standard: JB/T79 GB/T9113 HG/T20592 ASME B16. 5/47;
Nominal pressure: PN 0. 6~2.5MPa 150Lb~300Lb
Inspection and testing: GB/T13927 API598
Mode of driving: handle, electrically-driven, air-operated and so on

基本型号 Basic model

公称压力PN1.0-2.5(MPa)150Lb 公称口径DN20-500 (mm)/in3/4"-20"
Nominal pressure PN1.0-2.5 (MPa) 150Lb, nominal diameter DN20-500 (mm)/in3/4 "-20"

手动 闸阀 Manual gate valve	Z41PO	伞齿轮 闸阀 Bevel gear gate valve	Z541PO	气动 闸阀 Pneumatic gate valve	Z641PO	电动 闸阀 Electric gate valve	Z941PO
	Z41F ₄₆		Z541F ₄₆		Z641F ₄₆		Z941F ₄₆
	Z41F ₅₀₁		Z541F ₅₀₁		Z641F ₅₀₁		Z941F ₅₀₁

主要零部件材料表 List of Main Component Materials

序号 NO	零件名称 Name	球墨铸铁 Nodular cast iron	铸铁 Cast iron	不锈钢 Stainless steel		超低碳不锈钢 Ultra low carbon stainless steel	
		Q	C	P	R	P _L	R _L
1	阀体、阀盖、阀瓣 Valve body, valve cover, valve disc	QT450-10	WCB	CF 8	CF8M	CF 3	CF3M
2	阀杆 Valve stem	35	1Cr13	304	316	304L	316L
3	衬里层 Lining layer	PFA(F ₅₀₁)PTFE(F ₄)PCTFE(F ₃)FEP(F ₄₆)PFA(可溶F ₄) PO(聚烯烃)					
4	中法兰螺栓 Middle flange bolt	A193 B7	A193 B7	A193 B8	A193 B8	A193 B8	A193 B8
5	中法兰螺母 Middle flange nut	A194 2H	A194 2H	A194 8	A194 8	A194 8M	A194 8M
6	填料、垫片 Packing and gasket	PTFE					
7	支架 Bracket	HT250, WCB, CF8					
8	阀杆螺母 Stem nut	ZCuAl10Fe3					
9	手轮 Handwheel	KT330-08					

衬氟闸阀

Fluorine lined gate valve

PN10 衬氟闸阀

公称通径 Nominal Diameter		标准值 Standard value							参考值 Reference value		
DN(mm)	NPS(inch)	L	D	D1	D2	f	b	Z-Ød	H	D0	W(Kg)
15	1/2	140	95	65	45	2	16	4-Ø14	100	110	5.5
20	3/4	152	105	75	58	2	18	4-Ø14	140	100	7
25	1	165	115	85	68	2	18	4-Ø14	155	160	9
32	1 1/4	178	140	100	78	2	18	4-Ø18	185	160	10.5
40	1 1/2	240	150	110	88	2	18	4-Ø18	210	180	17.3
50	2	250	165	125	102	2	18	4-Ø18	295	180	18.05
65	2 1/2	270	185	145	122	2	18	8-Ø18	335	220	26
80	3	280	200	160	138	2	20	8-Ø18	402	250	32
100	4	300	220	180	158	2	20	8-Ø18	455	280	45
125	5	325	250	210	188	2	22	8-Ø18	605	320	60.2
150	6	350	285	240	212	2	22	8-Ø22	690	360	84
200	8	400	340	295	268	2	24	8-Ø22	727	400	141
250	10	450	395	350	320	2	26	12-Ø22	970	400	182
300	12	500	445	400	370	2	26	12-Ø22	1135	450	158
350	14	550	505	460	430	2	26	16-Ø22	1280	450	183.5
400	16	600	565	515	482	2	26	16-Ø26	1450	500	208.5
450	18	650	615	565	532	2	28	20-Ø26	1538	500	232
500	20	700	670	620	585	2	28	20-Ø26	1730	500	250

PN16 衬氟闸阀

公称通径 Nominal Diameter		标准值 Standard value							参考值 Reference value		
DN(mm)	NPS(inch)	L	D	D1	D2	f	b	Z-Ød	H	D0	W(Kg)
15	1/2	140	95	65	45	2	16	4-Ø14	100	110	5.5
20	3/4	152	105	75	58	2	18	4-Ø14	140	100	7
25	1	165	115	85	68	2	18	4-Ø14	155	160	9
32	1 1/4	178	140	100	78	2	18	4-Ø18	185	160	10.5
40	1 1/2	240	150	110	88	2	18	4-Ø18	210	180	17.3
50	2	250	165	125	102	2	18	4-Ø18	295	180	18.05
65	2 1/2	270	185	145	122	2	18	8-Ø18	335	220	26
80	3	280	200	160	138	2	20	8-Ø18	402	250	32
100	4	300	220	180	158	2	20	8-Ø18	455	280	45
125	5	325	250	210	188	2	22	8-Ø18	605	320	60.2
150	6	350	285	240	212	2	22	8-Ø22	690	360	84
200	8	400	340	295	268	2	24	12-Ø22	727	400	141
250	10	450	405	355	320	2	26	12-Ø26	970	400	182
300	12	500	460	410	378	2	28	12-Ø26	1135	450	158
350	14	550	520	470	428	2	30	16-Ø26	1280	450	183.5
400	16	600	580	525	490	2	32	16-Ø30	1450	500	208.5

衬氟闸阀

Fluorine lined gate valve

F

衬氟阀门系列
Fluorine Lined Valve Series

PN25 衬氟闸阀

公称通径 Nominal Diameter		标准值 Standard value							参考值 Reference value		
DN(mm)	NPS(inch)	L	D	D1	D2	f	b	Z-Ød	H	D0	W(Kg)
15	1/2	140	95	65	45	2	16	4-Ø14	100	110	5.5
20	3/4	152	105	75	58	2	18	4-Ø14	140	100	7
25	1	165	115	85	68	2	18	4-Ø14	155	160	9
32	1 1/4	178	140	100	78	2	18	4-Ø18	185	160	10.5
40	1 1/2	240	150	110	88	2	18	4-Ø18	210	180	17.3
50	2	250	165	125	102	2	20	4-Ø18	295	180	18.05
65	2 1/2	270	185	145	122	2	22	8-Ø18	335	220	26
80	3	280	200	160	138	2	24	8-Ø18	402	250	32
100	4	300	235	190	162	2	24	8-Ø22	455	280	45
125	5	325	270	220	188	2	26	8-Ø26	605	320	60.2
150	6	350	300	250	218	2	28	8-Ø26	690	360	84
200	8	400	360	310	278	2	30	12-Ø26	727	400	141
250	10	450	425	370	335	2	32	12-Ø30	970	400	182
300	12	500	485	430	395	2	34	16-Ø30	1135	450	158
350	14	550	555	490	450	2	38	16-Ø33	1280	450	183.5
400	16	600	620	550	505	2	40	16-Ø36	1450	500	208.5

Class150 衬氟闸阀

公称通径 Nominal Diameter		标准值 Standard value							参考值 Reference value		
DN(mm)	NPS(inch)	L	D	D1	D2	f	b	Z-Ød	H	D0	W(Kg)
15	1/2	140	90	60.3	34.9	2	11.6	4-Ø16	100	110	5.5
20	3/4	152	100	69.9	42.9	2	13.2	4-Ø16	140	100	7
25	1	165	110	79.4	50.8	2	14.7	4-Ø16	155	160	9
32	1 1/4	178	115	88.9	63.5	2	16.3	4-Ø16	185	160	10.5
40	1 1/2	240	125	98.4	73	2	17.9	4-Ø16	210	180	17.3
50	2	250	150	120.7	92.1	2	19.5	4-Ø18	295	180	18.05
65	2 1/2	270	180	139.7	104.8	2	22.7	4-Ø18	335	220	26
80	3	280	190	152.4	127	2	24.3	4-Ø18	402	250	32
100	4	300	230	190.5	157.2	2	24.3	8-Ø18	455	280	45
125	5	325	255	215.9	185.7	2	24.3	8-Ø22	605	320	60.2
150	6	350	280	241.3	215.9	2	25.9	8-Ø22	690	360	84
200	8	400	345	298.5	269.9	2	29	8-Ø22	727	400	141
250	10	450	405	362	323.8	2	30.6	12-Ø26	970	400	182
300	12	500	485	431.8	381	2	32.2	12-Ø26	1135	450	158
350	14	550	535	476.3	412.8	2	35.4	12-Ø30	1280	450	183.5
400	16	600	595	539.8	469.9	2	37	16-Ø30	1450	500	208.5

注：上图所列法兰数值为化工部标准，如需其它标准请在订货时注明。

Note: The flange values listed in the above figure are the standards of the Ministry of Chemical Industry. If other standards are required, please indicate them when ordering.

衬氟截止阀

Fluorine lined globe valve

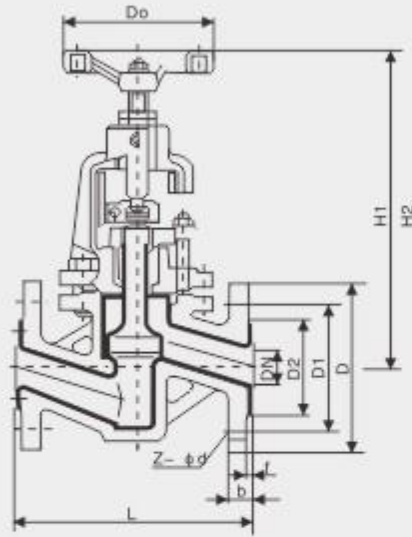

PTFE
FEP
PFA
F501
J41 衬氟直通式截止阀

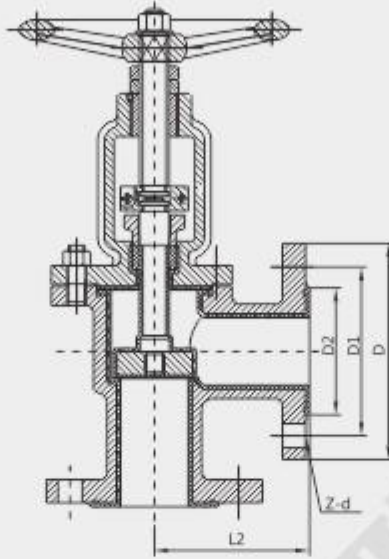

PTFE
FEP
PFA
F501
J44 衬氟角式截止阀

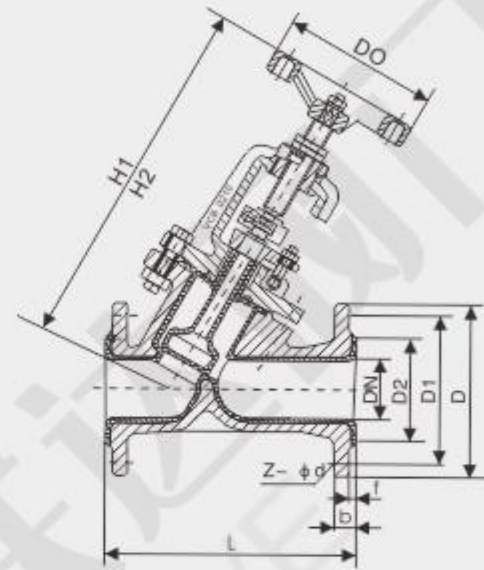

PTFE
FEP
PFA
F501
J45 衬氟直流式截止阀

结构特点:

Structural characteristics:

衬氟截止阀的启闭件是塞形的阀瓣，密封面呈平面或锥面，阀瓣沿流体的中心线作直线运动。阀杆的运动形式，有升降杆式（阀杆升降，手轮不升降），也有升降旋转杆式（手轮与阀杆一起旋转升降，螺母设在阀体上）。

衬氟截止阀具有以下优点：

1. 结构简单，制造和维修比较方便。
2. 工作行程小，启闭时间短。
3. 密封性好，密封面间摩擦力小，寿命较长。

衬氟截止阀的缺点如下：

1. 流体阻力大，开启和关闭时所需力较大。
2. 不适用于带颗粒、粘度较大、易结焦的介质。
3. 调节性能较差。

The opening and closing part of the fluorine lined globe valve is a plug shaped valve disc, with a flat or conical sealing surface. The valve disc moves in a straight line along the centerline of the fluid. The movement forms of the valve stem include the lifting rod type (valve stem lifting, handwheel not lifting), as well as the lifting rotating rod type (handwheel and valve stem rotating together to lift, nut installed on the valve body).

Fluorine lined globe valves have the following advantages:

1. Has the advantages of simple structure, convenient manufacture and repair.
2. Working stroke is small, open and close a short time.
3. Good sealing, the sealing surface between the friction force is small, longer life expectancy.

The disadvantages of fluorine lined globe valves are as follows:

1. Fluid resistance, force required to open and close the larger.
2. Do not apply with particles, viscosity, easy to medium coke.
3. Poor regulation performance.

设计标准
Design standards

设计制造规范: GB/T12239 HG/T3704
Design and Manufacturing Specification: GB/T12239 HG/T3704
结构长度: GB/T12221 ASME B16.10 HG/T3704
Structural length: GB/T12221 ASME B16.10 HG/T3704
连接尺寸: GB/T9113 JB/T79 HG/T20592 ASME B16.5
Connection size: GB/T9113 JB/T79 HG/T20592 ASME B16.5
试验与检验: GB/T13927 API 598
Testing and Inspection: GB/T13927 API 598

性能规范
Performance specifications

压力等级: PN1.0~2.5MPa 150Lb~300Lb
Pressure rating: PN1.0~2.5MPa 150Lb~300Lb
强度试验: 1.5MPa
Strength test: 1.5MPa
密封试验: 1.1MPa
Sealing test: 1.1MPa
气密试验: 0.6MPa
Air tightness test: 0.6MPa

衬氟截止阀

Fluorine lined globe valve

F

衬氟阀门系列
Fluorine Lined Valve Series

基本型号 Basic model									
公称压力PN1.0-2.5(MPa)150Lb 公称口径DN15-350 (mm)/in1/2'-14' Nominal pressure PN1.0-2.5 (MPa) 150Lb, nominal diameter DN15-350 (mm)/in1/2'-14'									
手动直通式 Manual through type	J41PO	手动直流式 Manual DC type	J45PO	蜗轮传动直通式 Worm gear transmission straight through type	J441PO	气动 Pneumatic	J641PO	电动 Electric	J941PO
	J41F46		J45F46		J441F46		J641F46		J941F46
	J41F501		J45F501		Pneumatic J441F501		Electric J641F501		J941F501

主要零部件材料表 List of Main Component Materials

序号 NO	零件名称 Name	球墨铸铁 Nodular cast iron	铸铁 Cast iron	不锈钢 Stainless steel		超低碳不锈钢 Ultra low carbon stainless steel	
		Q	C	P	R	PL	RL
1	阀体、阀盖 Valve body, valve cover	QT450-10	WCB	CF8	CF8M	CF3	CF3M
2	阀瓣、阀杆 Disc, stem	35	1Cr13	1Cr18Ni9	1Cr18Ni12MO2Ti	00Cr18Ni10	00Cr17Ni14MO2
3	活节螺栓 Live bolt	35	35	1Cr17Ni2	1Cr17Ni2	1Cr17Ni2	1Cr17Ni2
4	衬里层/阀座 Lining layer/valve seat	PFAF(F ₅₀₁)PTFE(F ₄)PCTFE(F ₃)FEP(F ₄₆)PFA(可溶F ₄)					
5	填料 Filler	PTFE(F ₄)					
6	填料压盖 Packing gland	WCB	WCB	CF8	CF8	CF8	CF8
7	阀杆螺母 Stem nut	ZCuAl10Fe3					
8	螺栓 Bolt	A193 B7	A193 B7	A193 B8	A193 B8	A193 B8	A193 B8
9	螺母 Nut	A194 2H	A194 2H	A194 8	A194 8	A194 8M	A194 8M
10	手轮 Handwheel	KT330-8					

产品名称 Valve body, valve cover	衬氟放料阀 Fluorine lined discharge valve	产品型号 Product model	F41F46 F41F46
公称口径 Disc, stem	DN25~DN200 DN25-DN200	结构形式 structural style	上展式、下展式 Upward and downward exhibition
公称压力 Live bolt	1.6MPa~2.5MPa~4.0MPa 1.6MPa-2.5MPa-4.0MPa	连接方式 Connection method	法兰 flange
适用温度 Lining layer/valve seat	-29°C~+180°C -29°C~+180°C	驱动方式 Driving method	手动、气动、电动 Manual, pneumatic, electric
阀体材质 Filler	铸钢、不锈钢 Cast steel, stainless steel	制造标准 Manufacturing standards	国标GB、德标DIN、美标API、ANSI National standard GB, German standard DIN, American standard API, ANSI
适用介质 Packing gland	水、液体、颗粒状颗粒等 Water, liquid, granular particles, etc		

产品说明 Product description

F41F46衬氟放料阀适用于-50℃~150℃的各种浓度的水、硫酸、盐酸、氢氟酸和各种有机酸、强酸、强氧化剂，FEP还适用于各种浓度的强碱有机溶剂以及其它腐蚀性气体、液体介质的管路上使用。

The F41F46 fluorine lined discharge valve is suitable for various concentrations of water, sulfuric acid, hydrochloric acid, hydrofluoric acid, and various organic acids, strong acids, and strong oxidizing agents between -50 °C and 150 °C. FEP is also suitable for various concentrations of strong alkaline organic solvents and other corrosive gases and liquid media. Used on pipelines with strong alkaline organic solvents and other corrosive gases and liquid media.

产品特点 Product Features

1. 采用氟塑料衬里层的放料阀，具有极高的化学稳定性，适用于任何强腐蚀性化学介质；
2. 流体阻力小，内壁光滑，流道通畅是所有阀类中流体阻力最小的一种。
3. 采用特殊模压工艺，将衬里材料衬于阀门壳体内壁，能耐强酸、强碱介质的腐蚀。衬里球面与PTFE阀座组合，密封性好，达到了零泄漏；
4. 可配置气动、电动、液动等多种驱动装置，实现远距离控制和自动化操作；

1. The discharge valve with fluorine plastic lining layer has extremely high chemical stability and is suitable for any strong corrosive chemical medium;
2. Low fluid resistance, smooth inner wall, and unobstructed flow channel are the least fluid resistance among all valve types.
3. Using a special molding process, the lining material is lined on the inner wall of the valve casing, which is resistant to strong acids and strong alkaline media. The combination of lining spherical surface and PTFE valve seat has good sealing performance, achieving zero leakage;
4. It can be equipped with various driving devices such as pneumatic, electric, and hydraulic to achieve remote control and automated operation;

衬氟截止阀

Fluorine lined globe valve

主要零件材质 Main component materials

序号 NO	零件名称 Name	球墨铸铁 Nodular cast iron	铸铁 Cast iron	不锈钢 Stainless steel		超低碳不锈钢 Ultra low carbon stainless steel	
		Q	C	P	R	PL	RL
1	阀体、阀盖、阀瓣 Valve body, valve cover, valve disc	QT450-10	WCB	CF 8	CF8M	CF 3	CF3M
2	阀杆 Valve stem	35	1Cr13	304	316	304L	316L
3	衬里层 Lining layer	PFA(F ₅₀)PTFE(F ₄)PCTFE(F ₃)FEP(F ₄₆)PFA(可溶F ₄) PO(聚烯烃)					
4	中法兰螺栓 Middle flange bolt	A193 B7	A193 B7	A193 B8	A193 B8	A193 B8	A193 B8
5	中法兰螺母 Middle flange nut	A194 2H	A194 2H	A194 8	A194 8	A194 8M	A194 8M
6	填料、垫片 Packing and gasket	PTFE					
7	支架 Bracket	HT250、WCB、CF8					
8	阀杆螺母 Stem nut	ZCuAl10Fe3					
9	手轮 Handwheel	KT330-08					

主要外形尺寸与连接尺寸 Main external dimensions and connection dimensions

PN16 衬氟截止阀

公称通径 Nominal Diameter		标准值 Standard value								参考值 Reference value			
DN (mm)	NPS (inch)	L	L2	D	D1	D2	f	b	Z-Ød	D0	H1	H2	W(Kg)
15	1/2	130	65	95	65	45	2	16	4-Ø14	100	240	265	8.16
20	3/4	150	75	105	75	58	2	18	4-Ø14	100	245	270	10.12
25	1	160	80	115	85	68	2	18	4-Ø14	120	250	275	11.72
32	1 1/4	180	90	140	100	78	2	18	4-Ø18	140	260	290	16.64
40	1 1/2	200	100	150	110	88	2	18	4-Ø18	140	285	320	21.88
50	2	230	115	165	125	102	2	18	4-Ø18	160	300	335	26.84
65	2 1/2	290	145	185	145	122	2	18	8-Ø18	180	355	400	40.3
80	3	310	155	200	160	138	2	20	8-Ø18	240	400	450	56.4
100	4	350	175	220	180	158	2	20	8-Ø18	240	455	495	65.36
125	5	400	200	250	210	188	2	22	8-Ø18	280	530	560	107.3
150	6	480	240	285	240	212	2	22	8-Ø22	320	610	650	137.6
200	8	600	300	340	295	268	2	24	12-Ø22	360	650	770	234
250	10	730	365	405	355	320	2	26	12-Ø26	400	690	710	250
300	12	850	425	460	410	378	2	28	12-Ø26	400	730	845	350

PN25 衬氟截止阀

15	1/2	130	65	95	65	45	2	16	4-Ø14	120	240	265	8.16
20	3/4	150	75	105	75	58	2	18	4-Ø14	120	245	270	10.12
25	1	160	80	115	85	68	2	18	4-Ø14	140	250	275	11.72
32	1 1/4	180	90	140	100	78	2	18	4-Ø18	160	260	290	16.64
40	1 1/2	200	100	150	110	88	2	18	4-Ø18	180	285	320	21.88
50	2	230	115	165	125	102	2	20	4-Ø18	180	300	335	26.84
65	2 1/2	290	145	185	145	122	2	22	8-Ø18	240	355	400	40.3
80	3	310	155	200	160	138	2	24	8-Ø18	280	400	450	56.4
100	4	350	175	235	190	162	2	24	8-Ø22	320	455	495	65.36
125	5	400	200	270	220	188	2	26	8-Ø26	320	530	560	107.3
150	6	480	240	300	250	218	2	28	8-Ø26	360	610	650	137.6
200	8	600	300	360	310	278	2	30	12-Ø26	400	745	750	234
250	10	730	365	425	370	335	2	32	12-Ø30	450	810	840	250
300	12	850	425	485	430	395	2	34	16-Ø30	550	980	970	350

注：上图所列法兰数值为化工部标准，如需其它标准请在订货时注明。

Note: The flange values listed in the above figure are the standards of the Ministry of Chemical Industry. If other standards are required, please indicate them when ordering.

氯气专用截止阀(专利型) JL41F-^{1.6}/_{2.5}CW

Chlorine dedicated globe valve (patented)

F

衬氟阀门系列
Fluorine Lined Valve Series

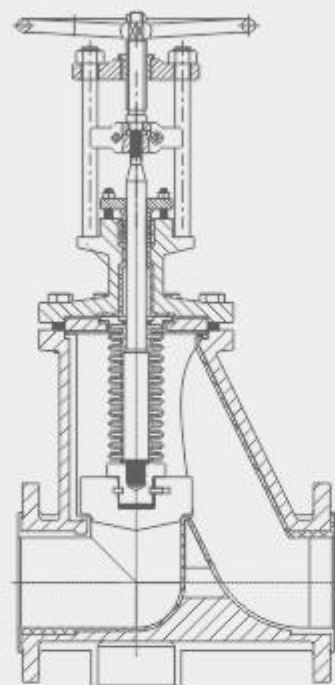

手动氯气专用截止阀

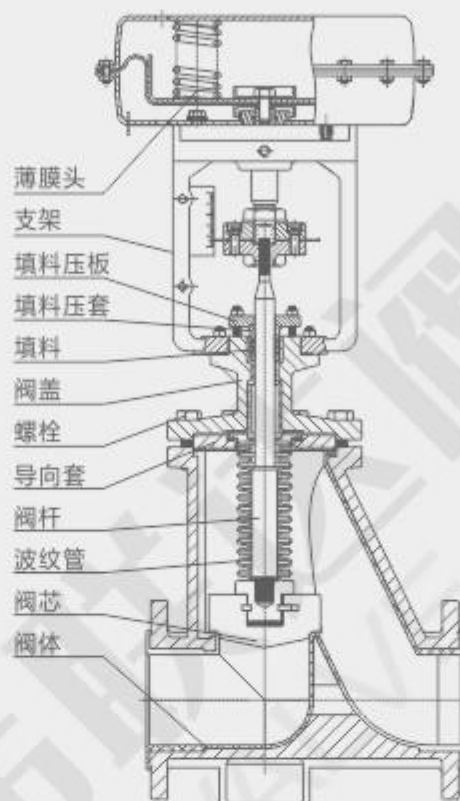

气动氯气专用截止阀

一、产品用途与特点

氯气专用波纹管截止阀是针对氯气、液氯以及各类高危险介质专用而设计的。它的密封除填料外还增加了波纹管密封，从而具有双重密封结构，能有效的阻止危险介质的泄漏。在结构上，结合国内外阀门应用的实际情况，阀瓣与阀座密封副采用了耐强腐蚀的聚四氟乙烯和司太立硬质合金，因而密封性能稳定、使用安全可靠、耐腐蚀性强、无介质内、外漏以及操作轻便等特点。其密封性、可维修性、安全性等主要技术指标达到世界知名产品的水平，故可代替进口产品。

二、结构与工作原理

氯气专用波纹管截止阀是一种防腐的直通式快开式手动阀，它根据介质具体特性，进行优选材料，在阀体材质上选用耐蚀合金，耐氯气、液氯腐蚀，耐低温可至 - 40°C，以最大限度保证工况条件的使用要求。

结构组件特点：

用波纹管形成第一道密封，可确保阀杆密封零泄漏。

填料函采用多级组合填料，并在波纹管之上形成了第二道密封，因而密封更加具有可靠性了。

中法兰采用凹面密封结构，即使在管道压力波动的情况下，也能保证中法兰可靠密封。

阀杆设有扁套结构，以防止波纹管扭转损坏，确保阀门使用寿命更长

密封副配对结构形式采用锥、平面型，密封自动补偿，达到双重保险的效果，密封性能稳定，使用寿命长

波纹管有两种：一种是金属材料制成，另一种是聚四氟乙烯材料制成。其两种波纹管均具有抗腐蚀功效，使用时根据工况条件酌情选定。

The purpose and characteristics

Chlorine special corrugated pipe cut-off valve for chlorine gas, liquid chlorine and all kinds of special designed for the high dangerous medium. Its seal besides packing also increased bellows seal, which has a dual sealing structure, can effectively prevent the leakage of dangerous medium. On the structure, combined with the actual situation of the valve in the domestic and overseas, disc and seat sealing pair adopted strong corrosion resistance of ptfе and cheese too hard alloy, thus sealing performance is stable, safe and reliable use, strong corrosion resistance, no internal and external leakage of medium, and convenient operation, etc. Its sealing, maintainability, security and other major technical indicators reached the level of world famous products, it can replace imported products.

Second, the structure and working principle

Chlorine dedicated bellows globe valve is a kind of anticorrosive cut-through quickly open the manual valve, it types according to specific features, selection of material, the material of the valve body with corrosion resistant alloy, chlorine gas, liquid chlorine corrosion resistant, low temperature resistant to 40 °C, guarantee the demand of working condition to the largest extent.

Structure characteristics of components:

Use the first seal corrugated pipe forming, can ensure that stem seal zero leakage.

Adopt multi-stage combination packing gland, and on corrugated pipe to form the second sealing, and sealing is more reliability.

The concave flange used in sealing structure, even in the case of pipeline pressure fluctuations, also can ensure the reliable sealing flange.

Stem has a flat structure, in order to prevent damage of corrugated pipe twist, ensure valve life longer

Sealing pair matching using cone, planar structure form, sealed automatic compensation, achieve the effect of double insurance, stable sealing performance, long service life

Corrugated pipe has two kinds: one kind is metal material, the other is a teflon material. The two bellows have corrosion effect, when used according to the working conditions reasonably selected.

F 氟气专用截止阀(专利型) JL41F-^{1.6}/_{2.5} CW
Chlorine dedicated globe valve (patented)

衬氟阀门系列
Fluorine Lined Valve Series

三. 外形尺寸
Overall dimensions

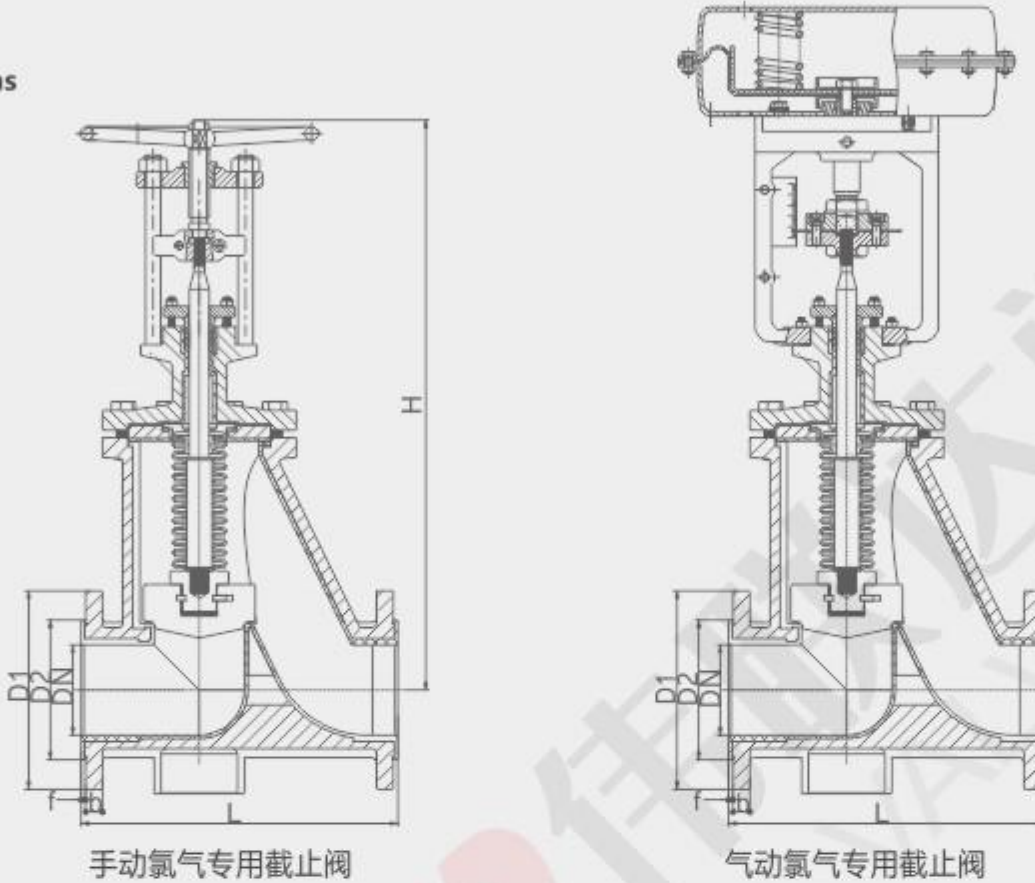

手动氟气专用截止阀

气动氟气专用截止阀

PN16 氟气专用阀

DN	NPS	L	D	D1	D2	z-Φd	b	f	H	A	重量 (KG)
25	1"	185	Φ115	Φ85	Φ65	4-Φ14	16	4	445	290	21.5
32	1 1/4"	200	Φ140	Φ100	Φ75	4-Φ18	16	4	450	290	23.9
40	1 1/2"	220	Φ150	Φ110	Φ85	4-Φ18	16	4	500	290	28.8
50	2"	250	Φ165	Φ125	Φ96	4-Φ18	16	4	500	290	31
65	2 1/2"	275	Φ185	Φ145	Φ120	8-Φ18	16	5	680	365	55
80	3"	300	Φ200	Φ160	Φ135	8-Φ18	18	5	680	365	60
100	4"	350	Φ220	Φ180	Φ155	8-Φ18	18	5	720	365	71
125	5"	400	Φ250	Φ210	Φ185	8-Φ18	20	5	890	475	110
150	6"	480	Φ285	Φ240	Φ210	8-Φ22	20	5	950	475	125
200	8"	600	Φ340	Φ295	Φ265	12-Φ22	22	6	1100	475	143

注: 重量包括阀本身重量和执行机构的重量

Note: Weight includes the weight of the valve itself and the weight of the actuator

四. 订货须知

Ordering instructions

1. 产品型号;
2. 公称通径 DN, 公称压力 PN;
3. 工况介质, 使用温度范围;
4. 阀组件和波纹管材料要求;
5. 其它特殊要求。

1. The product model;
2. Nominal diameter DN, nominal pressure PN;
3. The working condition of medium, the temperature range of use;
4. The valve components and corrugated pipe material requirements;
5. Other special requirements.

衬氟止回阀 Fluorine-lined check valve

结构特点:

Structural characteristics:

衬氟止回阀（又称逆止阀）这种类型的阀门的作用是只允许介质向一个方向流动，而且阻止方向流动。通常这种阀门是自动工作的，在一个方向流动的流体压力作用下，阀瓣打开；流体反方向流动时，由流体压力和阀瓣的自重合阀瓣作用于阀座，从而切断流动。它包括旋启式止回阀和升降式止回阀。

旋启式止回阀有一介铰链机构，还有一个像门一样的阀瓣自由地靠在倾斜的阀座表面上。为了确保阀瓣每次都能到达阀座面的合适位置，阀瓣设计在铰链机构，以便阀瓣具有足够有旋启空间，并使阀瓣真正的、全面的与阀座接触。

升降式止回阀的阀瓣座落位于阀体上阀座密封面上。此阀门除了阀瓣可以自由地升降之外，其余部分如同截止阀一样，流体压力使阀瓣从阀座密封面上抬起，介质回流导致阀瓣回落到阀座上，并切断流动。

Fluorine valve (also known as check valve) the role of this type of valve is only allowing media to flow in one direction, and stop the flow direction. Usually the valve is automatically work, the fluid pressure in a direction of flow, the valve flap to open; the opposite direction of fluid flow, the fluid pressure and the self valve coincidence role in the valve seat, thereby cutting off flow. It includes swing check valves and lift check valves.

Swing check valves are ordinary hinge, there is a door the same as the valve seat tilt freely against the surface. In order to ensure that each valve flap valve seat surface can reach the appropriate position, the valve flap design in the hinge, so that the valve flap is enough to swing space, and make a real flap valve, comprehensive engagement with the valve seat. Valve lift check valve is located at the valve seat sealing surface. In addition to this valve disc is free to lift, like the rest of the cut-off valve, the fluid pressure valve from the valve seat sealing surface lift, medium return led to the valve seat valve down, and cut off the flow.

设计标准 Design standards	设计制造规范: GB/T12239 HG/T3704 Design and Manufacturing Specification: GB/T12239 HG/T3704	性能规范 Performance specifications	压力等级: PN0.6~2.5MPa 150Lb Pressure rating: PN0.6~2.5MPa 150Lb
	结构长度: GB/T12221 ASME B16.10 HG/T3704 Structural length: GB/T12221 ASME B16.10 HG/T3704		强度试验: 1.5MPa Strength test: 1.5MPa
	连接尺寸: GB/T9113 JB/T79 HG/T20592 ASME B16.5 Connection size: GB/T9113 JB/T79 HG/T20592 ASME B16.5		密封试验: 1.1MPa Sealing test: 1.1MPa
	试验与检验: GB/T13927 API 598 Testing and Inspection: GB/T13927 API 598		气密试验: 0.6MPa Air tightness test: 0.6MPa

主要零部件材料表 List of Main Component Materials

序号 NO	零件名称 Name	球墨铸铁 Nodular cast iron	铸铁 Cast iron	不锈钢 Stainless steel		超低碳不锈钢 Ultra low carbon stainless steel	
		Q	C	P	R	P ^L	R ^L
1	阀体、阀盖 Valve body, valve cover	QT450-10	WCB	CF 8	CF8M	CF 3	CF3M
2	轴、阀瓣(板) Shaft, valve disc (plate)	35	1Cr13	1Cr18Ni9	1Cr18Ni12MO2Ti	00Cr18Ni10	00Cr17Ni14MO2
3	衬里层 Lining layer	PFA(F ₅₀₁)PTFE(F ₄)PCTFE(F ₃)FEP(F ₄₆)PFA(可溶F ₄) PO(聚烯烃)					
4	螺栓 Bolt	A193 B7	A193 B7	A193 B8	A193 B8	A193 B8	A193 B8
5	螺母 Nut	A194 2H	A194 2H	A194 8	A194 8	A194 8M	A194 8M

基本型号 Basic model							
公称压力PN0.6~1.6(MPa)150Lb 公称口径DN15-350 (mm)/in1/2"-14" Nominal pressure PN0.6~1.6 (MPa) 150Lb, nominal diameter DN15-350 (mm)/in1/2 "-14"							
直通 升降式 Straight lifting type	H7/41PO	立式 升降式 Vertical lifting type	H42PO		旋启式 Swing type	H7/44PO	
	H7/41F ₄₆		H42F ₄₆			H7/44F ₄₆	
	H7/41F ₅₀₁		H42F ₅₀₁			H7/44F ₅₀₁	

F

衬氟止回阀

Fluorine-lined check valve

衬氟阀门系列 Fluorine Lined Valve Series

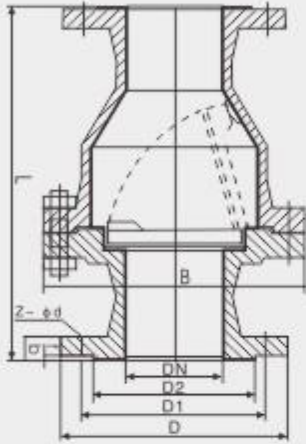

PTFE
FEP
PFA
F501
H44 衬氟旋启式止回阀

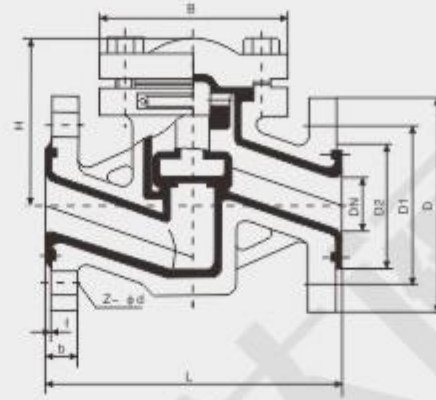

PTFE
FEP
PFA
F501
H41 衬氟直通升降式止回阀

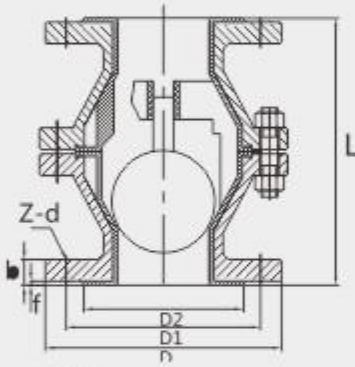

PTFE
FEP
PFA
F501
H40 衬氟升降浮球式止回阀

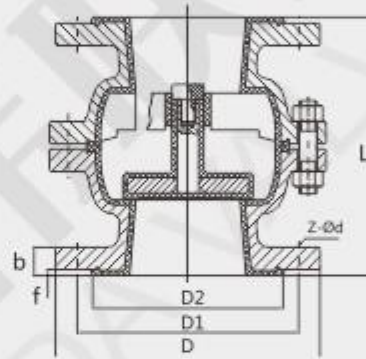

PTFE
FEP
PFA
F501
H42 衬氟升降式止回阀

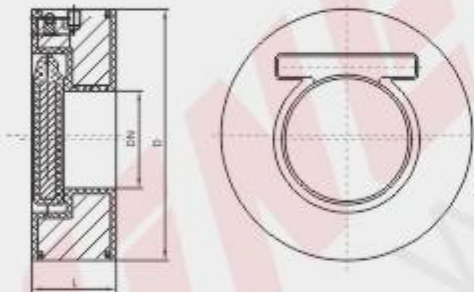

PTFE
FEP
PFA
F501
H74 衬氟单瓣旋启式止回阀

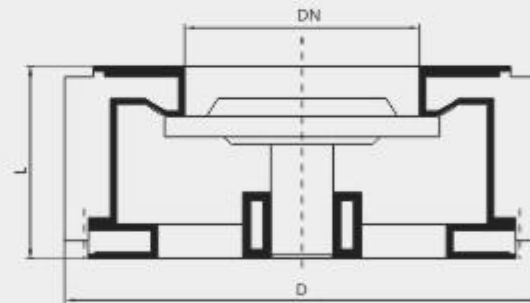

PTFE
FEP
PFA
F501
H71 衬氟对夹升降式止回阀

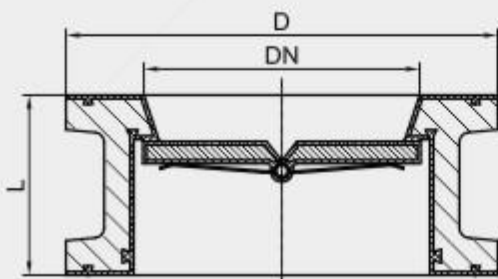

H76F-16 双瓣止回阀

衬氟止回阀

Fluorine-lined check valve

F

衬氟阀门系列
Fluorine Lined Valve Series

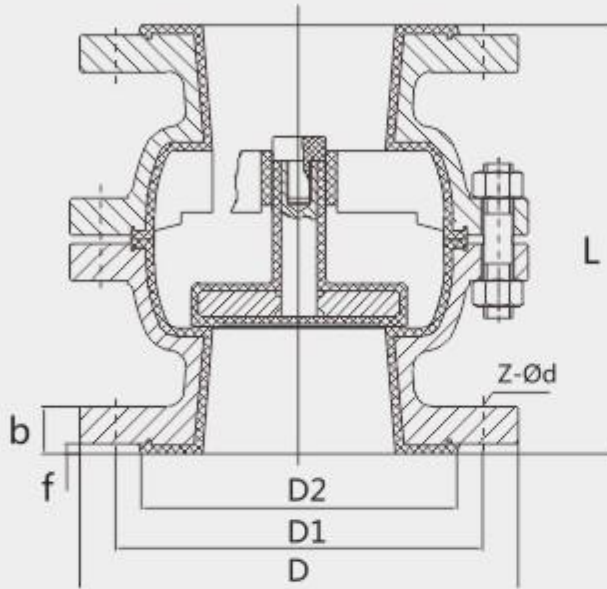

H42
PTFE
FEP
PFA
FS01
衬氟升降式止回阀

产品特性

设计标准: HG/T3704 GB/T12235 GB/T12236;
结构长度: GB/T12221 ASME B16. 10 HG/T3704;
法兰标准: JB/T79 GB/T9113 HG/T20592 ASME B16. 5/47;
连接方式: 对夹式、法兰式;
公称压力: PN 0.6~2.5MPa 150Lb~300Lb
检验试验: GB/T13927 API598

Product Features

Design standards: HG/T3704 GB/T12235 GB/T12236;
Structure length: GB/T12221 ASME B16. 10 HG/T3704;
Flange standard: JB/T79 GB/T9113 HG/T20592 ASME B16. 5/47;
Connection method: Wafer type, flange type;
Nominal pressure: PN 0.6~2.5MPa 150Lb~300Lb
Inspection test: GB/T13927 API598

PN10 衬氟止回阀

H42尺寸

公称通径 Nominal Diameter		标准值 Standard value							
In (inch)	DN (mm)	L	D	D1	D2	f	b	Z-Ød	W(Kg)
PN1.0(MPa)									
1/2	15	80	95	65	45	2	16	4-Φ14	-
3/4	20	90	105	75	58	2	18	4-Φ14	3.29
1	25	100	115	85	68	2	18	4-Φ14	3.65
1 1/4	32	110	140	100	78	2	18	4-Φ18	4.4
1 1/2	40	125	150	110	88	2	18	4-Φ18	5.99
2	50	140	165	125	102	2	18	4-Φ18	7.83
2 1/2	65	160	185	145	122	2	18	8-Φ18	10.45
3	80	185	200	160	138	2	20	8-Φ18	15.71
4	100	210	220	180	158	2	20	8-Φ18	19.53
5	125	250	250	210	188	2	22	8-Φ18	30
6	150	300	285	240	212	2	22	8-Φ22	40.1
8	200	380	340	295	268	2	24	8-Φ22	59.3
10	250	(430)	395	350	320	2	26	12-Φ22	84.08
12	300	457	445	400	370	2	26	12-Φ22	118
14	350	535	505	460	430	2	26	16-Φ22	147.6
16	400	572	565	515	482	2	26	16-Φ26	171.8
18	450	610	615	565	532	2	28	20-Φ26	198.3
20	500	610	670	620	585	2	28	20-Φ26	243

PN16 衬氟止回阀

公称通径 Nominal Diameter		标准值 Standard value							
In (inch)	DN (mm)	L	D	D1	D2	f	b	Z-Ød	W(Kg)
PN1.0(MPa)									
1/2	15	80	95	65	45	2	16	4-Φ14	-
3/4	20	90	105	75	58	2	18	4-Φ14	3.29
1	25	100	115	85	68	2	18	4-Φ14	3.65
1 1/4	32	110	140	100	78	2	18	4-Φ18	4.4
1 1/2	40	125	150	110	88	2	18	4-Φ18	5.99
2	50	140	165	125	102	2	18	4-Φ18	7.83
2 1/2	65	160	185	145	122	2	18	8-Φ18	10.45
3	80	185	200	160	138	2	20	8-Φ18	15.71
4	100	210	220	180	158	2	20	8-Φ18	19.53
5	125	250	250	210	188	2	22	8-Φ18	30
6	150	300	285	240	212	2	22	8-Φ22	40.1
8	200	380	340	295	268	2	24	12-Φ22	59.3
10	250	(430)	405	355	320	2	26	12-Φ26	84.08
12	300	457	460	410	378	2	28	12-Φ26	-
14	350	535	520	470	428	2	30	16-Φ26	-
16	400	572	580	525	490	2	32	16-Φ30	-
18	450	610	640	585	550	2	40	20-Φ30	-
20	500	610	715	650	610	2	44	20-Φ33	-

衬氟止回阀

Fluorine-lined check valve

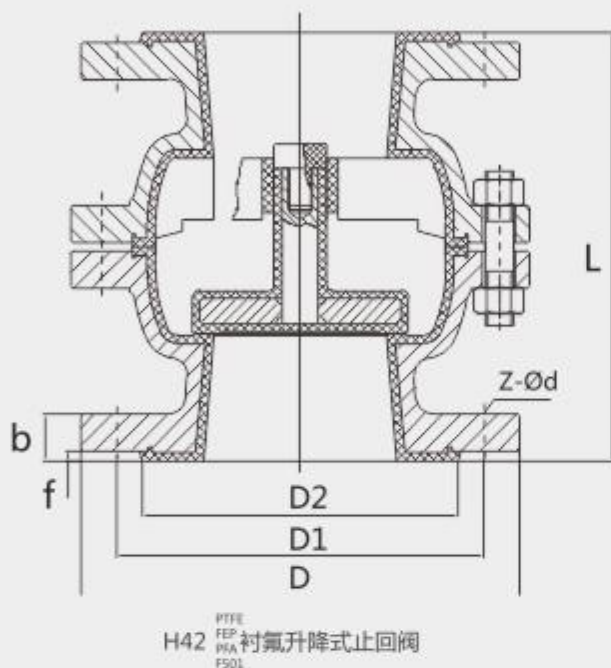

产品特性

设计标准: HG/T3704 GB/T12235 GB/T12236;
结构长度: GB/T12221 ASME B16. 10 HG/T3704;
法兰标准: JB/T79 GB/T9113 HG/T20592
ASME B16. 5/47;
连接方式: 对夹式、法兰式;
公称压力: PN0.6~2.5MPa 150Lb~300Lb
检验试验: GB/T13927 API598

Product Features

Design standards: HG/T3704 GB/T12235 GB/T12236;
Structure length: GB/T12221 ASME B16. 10 HG/T3704;
Flange standard: JB/T79 GB/T9113 HG/T20592 ASME B16. 5/47;
Connection method: flange type
Nominal pressure: PN0.6~2.5MPa 150Lb~300Lb
Inspection test: GB/T13927 API598

Class 150LB 衬氟止回阀

H42尺寸

公称通径 Nominal Diameter		标准值 Standard value							
In (inch)	DN (mm)	L	D	D1	D2	f	b	Z-Φd	W(Kg)
150Lb									
1/2	15	80	90	60.3	34.9	2	11.6	4-Φ16	3
3/4	20	90	100	69.9	42.9	2	13.2	4-Φ16	3.29
1	25	100	110	79.4	50.8	2	14.7	4-Φ16	3.65
1 1/4	32	110	115	88.9	63.5	2	16.3	4-Φ16	4.4
1 1/2	40	125	125	98.4	73	2	17.9	4-Φ16	5.99
2	50	140	150	120.7	92.1	2	19.5	4-Φ18	7.83
2 1/2	65	160	180	139.7	104.8	2	22.7	4-Φ18	10.45
3	80	185	190	152.4	127	2	24.3	4-Φ18	15.71
4	100	210	230	190.5	157.2	2	24.3	8-Φ18	19.53
5	125	250	255	215.9	185.7	2	24.3	8-Φ22	30
6	150	300	280	241.3	215.9	2	25.9	8-Φ22	40.1
8	200	380	345	298.5	269.9	2	29	8-Φ22	59.3
10	250	430	405	362	323.8	2	30.6	12-Φ26	84.08
12	300	457	485	431.8	381	2	32.2	12-Φ26	180
14	350	535	535	476.3	412.8	2	35.4	12-Φ30	220
16	400	572	595	539.8	469.9	2	37	16-Φ30	275
18	450	610	635	577.9	533.4	2	40.1	16-Φ33	300
20	500	610	700	635	584.2	2	43.3	20-Φ33	392

衬氟止回阀

Fluorine-lined check valve

F

衬氟阀门系列
Fluorine Lined Valve Series

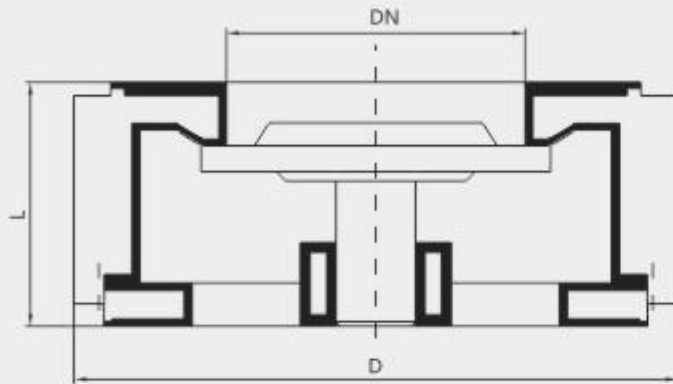

H71
PTFE
FEP
PFA 衬氟对夹升降式止回阀
F501

产品特性:

设计标准: HG/T3704 GB/T12235 GB/T12236;
结构长度: GB/T12221 ASME B16. 10 HG/T3704;
法兰标准: JB/T79 GB/T9113 HG/T20592 ASME B16. 5/47;
连接方式: 对夹式、法兰式;
公称压力: PN 0.6~2.5MPa 150Lb~300Lb
检验试验: GB/T13927 API598

Product Features

design standards: HG/T3704 GB/T12235 GB/T12236;
Structure length: GB/T12221 ASME B16. 10 HG/T3704;
Flange standard: JB/T79 GB/T9113 HG/T20592 ASME B16. 5/47;
Connection method: Wafer type, flange type;
Nominal pressure: PN 0.6~2.5MPa 150Lb~300Lb
Inspection test: GB/T13927 API598

PN6/PN10/PN16 衬氟止回阀

H71尺寸

公称通径 Nominal Diameter		标准值 Standard value								
In (inch)	DN (mm)	PN0.6(MPa)			PN1.0(MPa)			PN1.6(MPa)		
		L	D	W(Kg)	L	D	W(Kg)	L	D	W(Kg)
2	50	46	90	0.8	46	102	1.0	46	102	1.2
2 1/2	65	46	110	1.0	46	122	1.4	46	122	1.6
3	80	64	128	1.4	64	138	2.7	64	138	3.0
4	100	64	148	2.5	64	158	3.6	64	158	4.5
5	125	70	178	3.2	70	188	4.2	70	188	5.0
6	150	76	202	4.0	76	212	5.6	76	212	6.2
8	200	89	258	5.2	89	268	6.4	89	268	7
10	250	114	312	6.4	114	320	8.2	114	320	8.5
12	300	114	365	8.5	114	370	9.5	114	378	10.3
14	350	127	415	9.2	127	430	12.8	127	428	13.5
16	400	140	465	13	140	482	14.8	140	490	15.6
18	450	152	520	16	152	532	20	152	550	22
20	500	152	570	21	152	585	23.5	152	610	26
24	600	178	670	27	178	685	30	178	725	35

Class125/150/300LB 衬氟止回阀

ANSI

2	50	46	90	0.8	46	102	1.0	46	102	1.2
2 1/2	65	46	110	1.0	46	122	1.4	46	122	1.6
3	80	64	128	1.4	64	138	2.7	64	138	3.0
4	100	64	148	2.5	64	158	3.6	64	158	4.5
5	125	70	178	3.2	70	188	4.2	70	188	5.0
6	150	76	202	4.0	76	212	5.6	76	212	6.2
8	200	89	258	5.2	89	268	6.4	89	268	7
10	250	114	312	6.4	114	320	8.2	114	320	8.5
12	300	114	365	8.5	114	370	9.5	114	378	10.3
14	350	127	415	9.2	127	430	12.8	127	428	13.5
16	400	140	465	13	140	482	14.8	140	490	15.6
18	450	152	520	16	152	532	20	152	550	22
20	500	152	570	21	152	585	23.5	152	610	26
24	600	178	670	27	178	685	30	178	725	35

衬氟止回阀

Fluorine-lined check valve

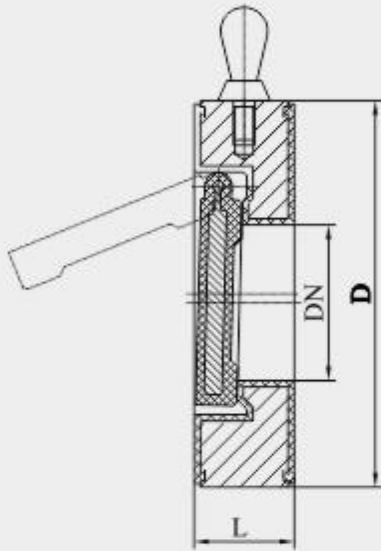

H74F-16
衬氟单瓣旋启式止回阀

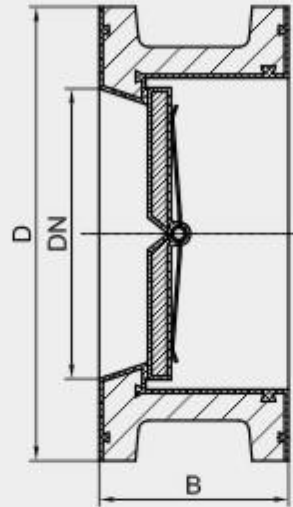

H76F-16
衬氟双瓣旋启式止回阀

产品特性

设计标准: HG/T3704 GB/T12235 GB/T12236;
结构长度: GB/T12221 ASME B16. 10 HG/T3704;
法兰标准: JB/T79 GB/T9113 HG/T20592 ASME B16. 5/47;
连接方式: 对夹式、法兰式;
公称压力: PN 0.6~2.5MPa 150Lb~300Lb
检验试验: GB/T13927 API598

Product Features

design standards: HG/T3704 GB/T12235 GB/T12236;
Structure length: GB/T12221 ASME B16. 10 HG/T3704;
Flange standard: JB/T79 GB/T9113 HG/T20592 ASME B16. 5/47;
Connection method: flange type
Nominal pressure: PN 0.6~2.5MPa 150Lb~300Lb
Inspection test: GB/T13927 API598

PN6/PN10/PN16 衬氟止回阀

H74尺寸

公称通径 Nominal Diameter		标准值 Standard value									
In (inch)	DN (mm)	PN0.6(MPa)				PN1.0(MPa)			PN1.6(MPa)		
		L	B	D	W(Kg)	L	D	W(Kg)	L	D	W(Kg)
2	50	43	60	90	2.2	43	102	2.5	43	102	3.66
2 1/2	65	46	67	110	2.6	46	122	3.0	46	122	5.58
3	80	46	73	128	5.0	46	138	5.7	46	138	6.6
4	100	52	73	148	9.6	52	158	10.4	52	158	9.02
5	125	56	86	178	11.2	56	188	13.5	56	188	13.5
6	150	56	98	202	13	56	212	15.5	56	212	17.44
8	200	60	127	258	15.2	60	268	18.7	60	268	28.88
10	250	68	146	312	22.5	68	320	28.5	68	320	46.84
12	300	78	181	365	30	78	370	35	78	378	67.6
14	350	78	184	415	43.2	78	430	48.2	78	428	99.68
16	400	102	190	465	55.2	102	482	63.2	102	490	120.2
18	450	114	203	520	74.8	114	532	83.2	114	550	140.8
20	500	127	219	570	89.1	127	585	98.1	127	610	170.6

衬氟止回阀 Fluorine-lined check valve

F

衬氟阀门系列
Fluorine Lined Valve Series

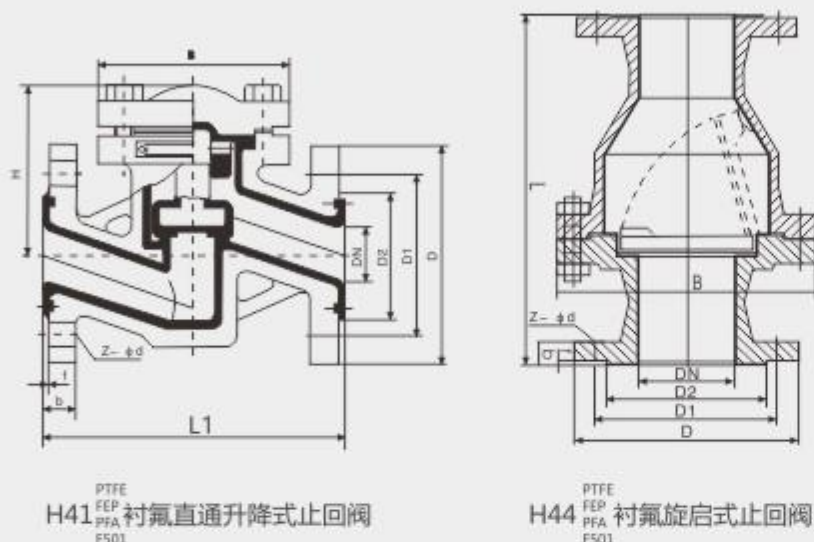

产品特性

设计标准: HG/T3704 GB/T12235 GB/T12236;
结构长度: GB/T12221 ASME B16. 10 HG/T3704;
法兰标准: JB/T79 GB/T9113 HG/T20592 ASME B16. 5/47;
连接方式: 对夹式、法兰式;
公称压力: PN 0.6~2.5MPa 150Lb~300Lb
检验试验: GB/T13927 API598

Product Features

design standards: HG/T3704 GB/T12235 GB/T12236;
Structure length: GB/T12221 ASME B16. 10 HG/T3704;
Flange standard: JB/T79 GB/T9113 HG/T20592 ASME B16. 5/47;
Connection method: flange type
Nominal pressure: PN 0.6~2.5MPa 150Lb~300Lb
Inspection test: GB/T13927 API598

PN6 衬氟止回阀

H41和H44尺寸

公称通径 Nominal Diameter		标准值 Standard value							参考值 Reference value			
DN (mm)	NPS (inch)	L1	D	D1	D2	f	b	Z-φd	D0	H	W(Kg)	L
PN0.6(MPa)												
15	1/2	130	80	55	40	2	12	4-φ11	105	55	3	130
20	3/4	150	90	65	50	2	14	4-φ11	115	58	3.6	150
25	1	160	100	75	60	2	14	4-φ11	128	60	4.37	160
32	1 1/4	180	120	90	70	2	14	4-φ14	145	75	6.33	180
40	1 1/2	200	130	100	80	2	14	4-φ14	160	82	8.75	200
50	2	230	140	110	90	2	14	4-φ14	178	95	11.4	230
65	2 1/2	290	160	130	110	2	14	4-φ14	205	105	17.42	290
80	3	310	190	150	128	2	16	4-φ18	230	120	22	310
100	4	350	210	170	148	2	16	4-φ18	255	135	28	350
125	5	400	240	200	178	2	18	8-φ18	305	158	49	400
150	6	480	265	225	202	2	18	8-φ18	345	180	63.4	480
200	8	600	320	280	258	2	20	8-φ18	415	215	71.65	495
250	10	730	375	335	312	2	22	12-φ18	490	240	75	622
300	12	850	440	395	365	2	22	12-φ22	540	265	92.5	698
350	14	-	490	445	415	2	22	12-φ22	585	300	107.5	787

PN10 衬氟止回阀

15	1/2	130	95	65	45	2	16	4-φ14	105	55	3	130
20	3/4	150	105	75	58	2	18	4-φ14	115	58	3.6	150
25	1	160	115	85	68	2	18	4-φ14	128	60	4.37	160
32	1 1/4	180	140	100	78	2	18	4-φ18	145	75	6.33	180
40	1 1/2	200	150	110	88	2	18	4-φ18	160	82	8.75	200
50	2	230	165	125	102	2	18	4-φ18	178	95	11.4	230
65	2 1/2	290	185	145	122	2	18	8-φ18	205	105	17.42	290
80	3	310	200	160	138	2	20	8-φ18	230	120	22	310
100	4	350	220	180	158	2	20	8-φ18	255	135	28	350
125	5	400	250	210	188	2	22	8-φ18	305	158	49	400
150	6	480	285	240	212	2	22	8-φ22	345	180	63.4	480
200	8	600	340	295	268	2	24	8-φ22	415	215	71.65	495
250	10	730	395	350	320	2	26	12-φ22	490	240	82.5	622
300	12	850	445	400	370	2	26	12-φ22	540	265	95	698
350	14	-	505	460	430	2	26	16-φ22	585	300	112.5	787

注: 上图所列止回阀数值为化工部标准, 如需其它标准请在订货时注明。

Note: The check valve values listed in the above figure are the standards of the Ministry of Chemical Industry. If other standards are required, please indicate them when ordering.

衬氟止回阀

Fluorine-lined check valve

H40球形止回阀

H41 PTFE FEP PFA 衬氟直通升降式止回阀
FS01

H44 PTFE FEP PFA 衬氟旋启式止回阀
FS01

产品特性

设计标准: HG/T3704 GB/T12235 GB/T12236;
 结构长度: GB/T12221 ASME B16.10 HG/T3704;
 法兰标准: JB/T79 GB/T9113 HG/T20592 ASME B16.5/47;
 连接方式: 对夹式、法兰式;
 公称压力: PN 0.6~2.5MPa 150Lb~300Lb
 检验试验: GB/T13927 API598

Product Features

design standards: HG/T3704 GB/T12235 GB/T12236;
 Structure length: GB/T12221 ASME B16.10 HG/T3704;
 Flange standard: JB/T79 GB/T9113 HG/T20592 ASME B16.5/47;
 Connection method: flange type
 Nominal pressure: PN 0.6~2.5MPa 150Lb~300Lb
 Inspection test: GB/T13927 API598

PN16 衬氟止回阀

H41和H44尺寸

公称通径 Nominal Diameter		标准值 Standard value							参考值 Reference value			
DN (mm)	NPS (inch)	L1	D	D1	D2	f	b	Z-Ød	D0	H	W(Kg)	L
PN1.6(MPa)												
15	1/2	130	95	65	45	2	16	4-Ø14	110	55	3.83	130
20	3/4	150	105	75	58	2	18	4-Ø14	120	58	5.07	150
25	1	160	115	85	68	2	18	4-Ø14	135	60	5.23	160
32	1 1/4	180	140	100	78	2	18	4-Ø18	150	75	6.36	180
40	1 1/2	200	150	110	88	2	18	4-Ø18	165	82	9.39	200
50	2	230	165	125	102	2	18	4-Ø18	185	95	12.76	230
65	2 1/2	290	185	145	122	2	18	8-Ø18	210	105	17.5	290
80	3	310	200	160	138	2	20	8-Ø18	235	120	20.91	310
100	4	350	220	180	158	2	20	8-Ø18	260	135	26.2	350
125	5	400	250	210	188	2	22	8-Ø18	310	158	35	400
150	6	480	285	240	212	2	22	8-Ø22	350	180	42.3	480
200	8	600	340	295	268	2	24	12-Ø22	420	215	74.2	495
250	10	730	405	355	320	2	26	12-Ø26	505	240	110	622
300	12	850	460	410	378	2	28	12-Ø26	560	265	190	698
350	14	-	520	470	428	2	30	16-Ø26	605	300	230	787

Class150LB 衬氟止回阀

15	1/2	130	90	60.3	34.9	2	11.6	4-Ø16	110	55	3.83	130
20	3/4	150	100	69.9	42.9	2	13.2	4-Ø16	120	58	5.07	150
25	1	160	110	79.4	50.8	2	14.7	4-Ø16	135	60	5.25	160
32	1 1/4	180	115	88.9	63.5	2	16.3	4-Ø16	150	75	6.36	180
40	1 1/2	200	125	98.4	73	2	17.9	4-Ø16	165	82	9.39	200
50	2	230	150	120.7	92.1	2	19.5	4-Ø18	185	95	12.76	230
65	2 1/2	290	180	139.7	104.8	2	22.7	4-Ø18	210	105	17.5	290
80	3	310	190	152.4	127	2	24.3	4-Ø18	235	120	20.91	310
100	4	350	230	190.5	157.2	2	24.3	8-Ø18	260	135	26.2	350
125	5	400	255	215.9	185.7	2	24.3	8-Ø22	310	158	35	400
150	6	480	280	241.3	215.9	2	25.9	8-Ø22	350	180	42.3	480
200	8	600	345	298.5	269.9	2	29	8-Ø22	420	215	74.2	495
250	10	730	405	362	323.8	2	30.6	12-Ø26	505	240	110	622
300	12	850	485	431.8	381	2	32.2	12-Ø26	560	265	190	698
350	14	-	535	476.3	412.8	2	35.4	12-Ø30	605	300	230	787

注: 上图所列法兰数值为化工部标准, 如需其它标准请在订货时注明。

Note: The flange values listed in the above figure are the standards of the Ministry of Chemical Industry. If other standards are required, please indicate them when ordering.

衬氟隔膜阀

Fluorine-lined diaphragm valve

F

衬氟阀门系列
Fluorine Lined Valve Series

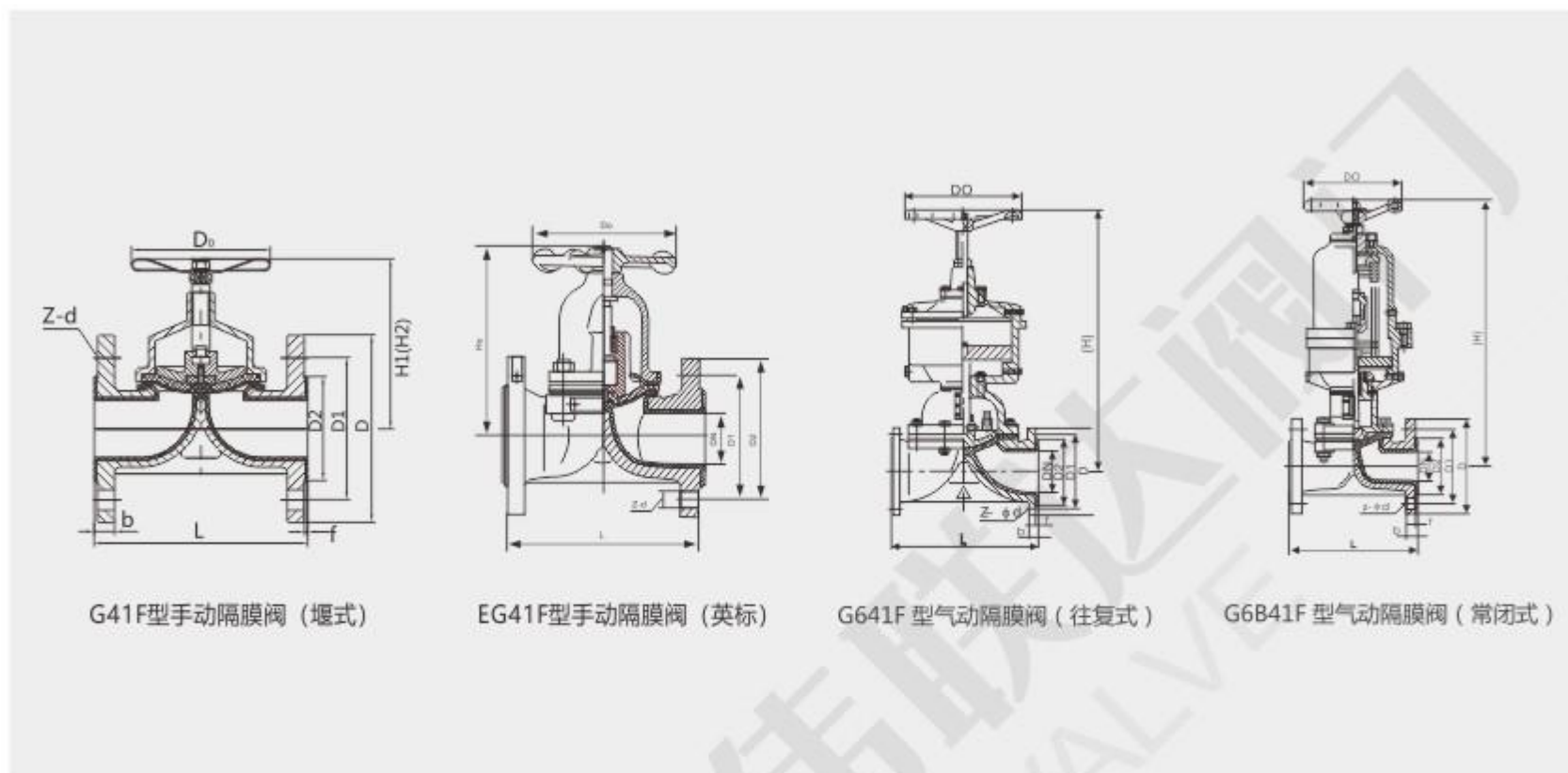

G41F型手动隔膜阀（堰式）

EG41F型手动隔膜阀（英标）

G641F 型气动隔膜阀（往复式）

G6B41F 型气动隔膜阀（常闭式）

结构特点：

衬氟隔膜阀是一种特殊形式的截断阀，出现于20世纪20年代。它的启闭件是一块用软质材料制成的隔膜，把阀体内腔与阀盖内腔及驱动部件隔开，故称隔膜阀。

最突出特点是隔膜把下部阀体内腔与上部阀盖内腔隔开，使位于隔膜上方的阀杆、阀瓣等零件不受介质腐蚀，省去了填料密封结构，且不会产生介质外漏。

是目前世界最理想的防腐材料，已广泛用于旋转成型的大型设备和管道件内衬。

Structural characteristics:

Fluorine-lined diaphragm valve is a special form of shut-off valve, which appeared in the 1920s. Its opening and closing part is a diaphragm made of soft material, which separates the inner cavity of the valve body from the inner cavity of the valve cover and the driving parts, so it is called a diaphragm valve.

The most prominent feature is that the diaphragm separates the inner cavity of the lower valve body from the inner cavity of the upper valve cover, so that the valve stem, valve clack and other parts located above the diaphragm are not corroded by the medium, and the packing seal structure is omitted, and no medium leakage occurs.

It is the most ideal anti-corrosion material in the world, and it has been widely used in the lining of large-scale equipment and pipe fittings of rotary forming.

设计标准

Design standards

设计制造规范：GB/T12239 HG/T3704
Design and Manufacturing Specification: GB/T12239 HG/T3704

结构长度：GB/T12221 ASME B16.10 HG/T3704
Structural length: GB/T12221 ASME B16.10 HG/T3704

连接尺寸：GB/T9113 JB/T79 HG/T20592 ASME B16.5
Connection size: GB/T9113 JB/T79 HG/T20592 ASME B16.5

试验与检验：GB/T13927 API 598
Testing and Inspection: GB/T13927 API 598

性能规范

Performance specifications

压力等级：PN1.0~1.6MPa 150Lb
Pressure rating: PN1.0~1.6MPa 150Lb

强度试验：1.5MPa
Strength test: 1.5MPa

密封试验：0.8MPa
Sealing test: 0.8MPa

气密试验：0.6MPa
Air tightness test: 0.6MPa

衬氟隔膜阀

Fluorine-lined diaphragm valve

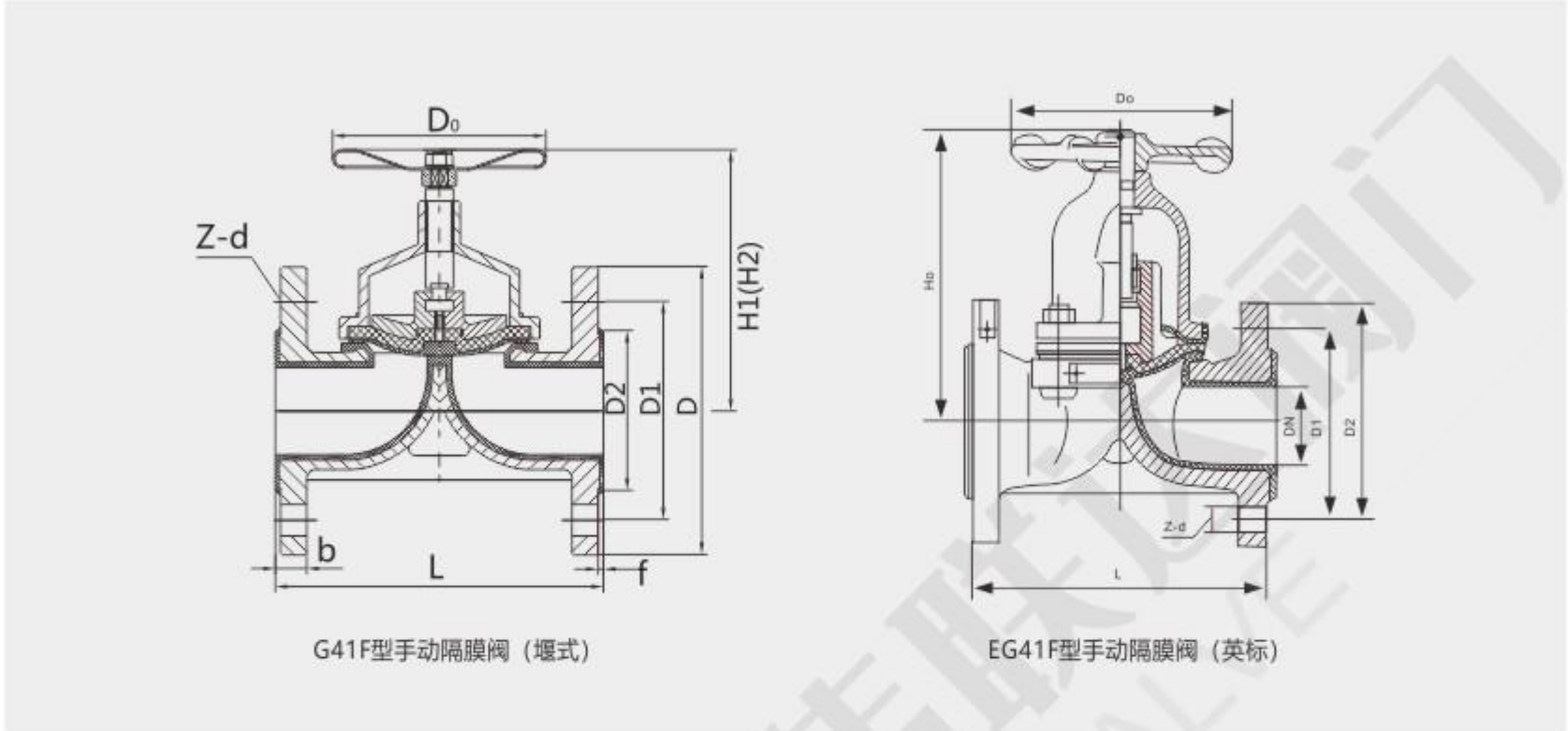

G41F型手动隔膜阀 (堰式)

EG41F型手动隔膜阀 (英标)

基本型号 Basic model					
公称压力PN1.0-1.6(MPa)150Lb 公称口径DN15-300 (mm)/in1/2'-12' Nominal pressure PN0.6~1.6 (MPa) 150Lb, nominal diameter DN15-350 (mm)/in1/2"-14"					
手动 Manual	G41PO(堰式Weir type)	气动 Pneumatic	G641PO(往复式Reciprocating)	电动 Electric	G941PO(普通型Common)
	G41F ₄₆ (堰式Weir type)		G641F ₄₆ (往复式Reciprocating)		G941F ₄₆ (全衬里fully lined)
	G41F ₅₀₁ (堰式Weir type)		G641F ₅₀₁ (往复式Reciprocating)		G941F ₅₀₁ (全衬里fully lined)
	G41PO(直流式Straight-flow)		G6B41PO(常闭式Normally closed)		G9B41PO(防爆型Explosion proof type)
	G41F ₄₆ (直流式Straight-flow)		G6B41F ₄₆ (常闭式Normally closed)		G9B41F ₄₆ (防爆型Explosion proof type)
	G41F ₅₀₁ (直流式Straight-flow)		G6B41F ₅₀₁ (常闭式Normally closed)		G9B41F ₅₀₁ (防爆型Explosion proof type)

主要零部件材料表:

序号 NO	零件名称 Name	球墨铸铁 Nodular cast iron	铸铁 Cast iron	不锈钢 Stainless steel		超低碳不锈钢 Ultra low carbon stainless steel	
		Q	C	P	R	P _L	R _L
1	阀体、阀盖、阀瓣 Valve body, valve cover, valve disc	QT450-10	WCB	CF8	CF8M	CF3	CF3M
2	阀杆 Valve stem	35	1Cr13	1Cr18Ni9	1Cr18Ni12MO2Ti	00Cr18Ni10	00Cr17Ni14MO2
3	隔膜 The diaphragm	FEP(F ₄₆)/CR(氯丁橡胶) PFA(可溶性聚四氟乙烯)/FPDM(乙丙橡胶)					
4	衬里层 Lining layer	PFAF(F ₅₀₁)PTFE(F ₄)PCTFE(F ₃)FEP(F ₄₆)PFA(可溶F ₄) PO(聚烯烃)					
5	阀杆螺母 Stem nut	ZCuAl10Fe3					
6	螺栓 Bolt	A193 B7	A193 B7	A193 B8	A193 B8	A193 B8	A193 B8
7	螺母 Nut	A194 2H	A194 2H	A194 8	A194 8	A194 8M	A194 8M
8	手轮 Handwheel	WCB					

衬氟隔膜阀

Fluorine-lined diaphragm valve

F

衬氟阀门系列
Fluorine Lined Valve Series

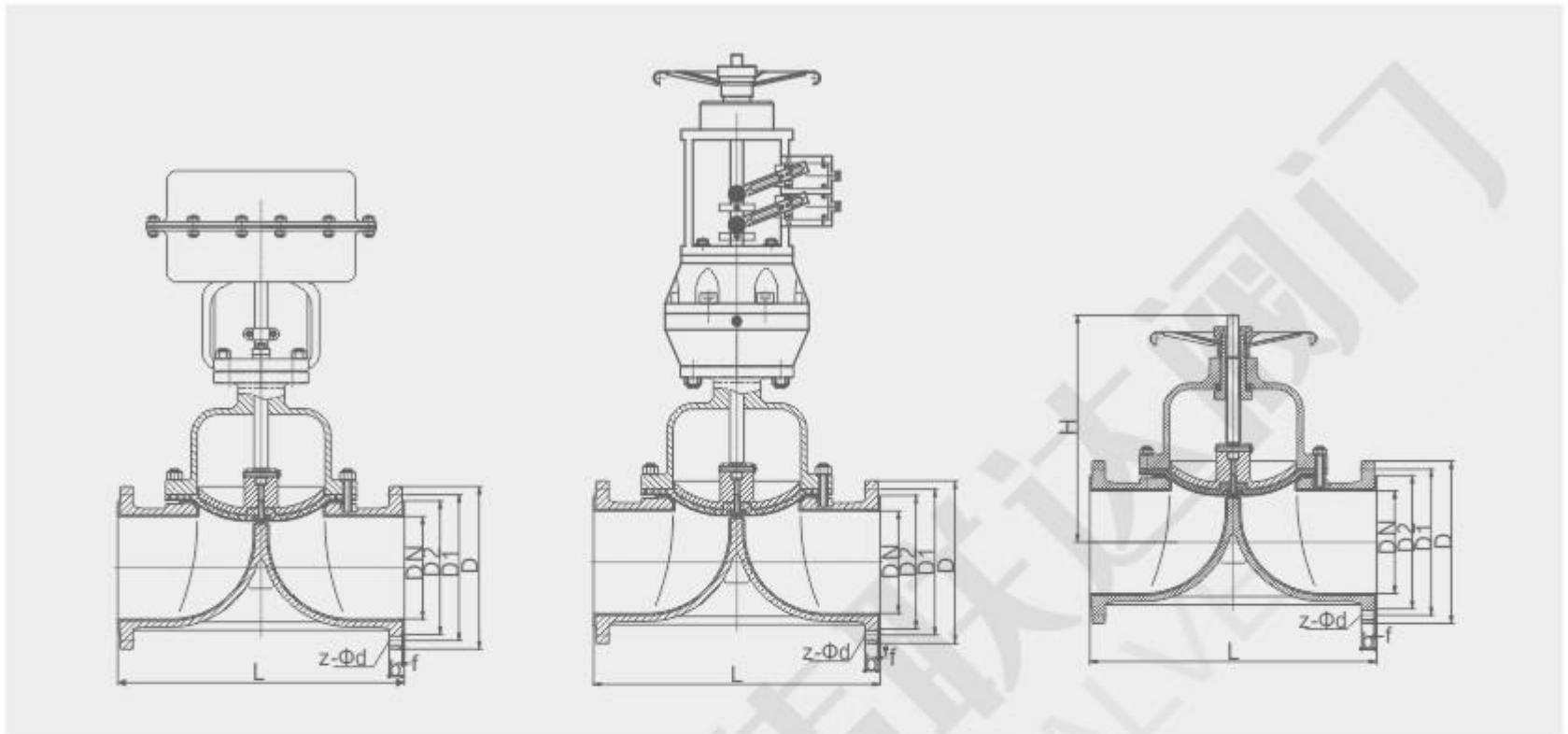

PN10衬氟隔膜阀

DN	NPS	L	D	D1	D2	Z-Φd	b	f	H	重量(Kg)
15	1/2"	130	Φ95	Φ65	Φ45	4-Φ14	14	4	110	2.8
20	3/4"	135	Φ105	Φ75	Φ55	4-Φ14	16	4	115	3.5
25	1"	145	Φ115	Φ85	Φ65	4-Φ14	16	4	120	3.8
32	1 1/4"	160	Φ140	Φ100	Φ75	4-Φ18	16	4	125	6.2
40	1 1/2"	180	Φ150	Φ110	Φ85	4-Φ18	16	4	135	7.74
50	2"	210	Φ165	Φ125	Φ96	4-Φ18	16	4	155	9.92
65	2 1/2"	250	Φ185	Φ145	Φ120	8-Φ18	16	4	170	13.5
80	3"	300	Φ200	Φ160	Φ135	8-Φ18	18	4	200	19.5
100	4"	350	Φ220	Φ180	Φ155	8-Φ18	18	4	270	26.5
125	5"	400	Φ250	Φ210	Φ185	8-Φ18	20	5	335	39
150	6"	460	Φ285	Φ240	Φ210	8-Φ22	20	5	370	56.8
200	8"	570	Φ340	Φ295	Φ265	8-Φ22	22	6	450	83
250	10"	680	Φ395	Φ350	Φ320	12-Φ22	24	6	545	150
300	12"	790	Φ445	Φ400	Φ372	12-Φ22	26	6	585	171

PN16衬氟隔膜阀

DN	NPS	L	D	D1	D2	Z-Φd	b	f	H	重量(Kg)
15	1/2"	130	Φ95	Φ65	Φ45	4-Φ14	14	4	110	2.8
20	3/4"	135	Φ105	Φ75	Φ55	4-Φ14	16	4	115	3.5
25	1"	145	Φ115	Φ85	Φ65	4-Φ14	16	4	120	3.8
32	1 1/4"	160	Φ140	Φ100	Φ75	4-Φ18	16	4	125	6.2
40	1 1/2"	180	Φ150	Φ110	Φ85	4-Φ18	16	4	135	7.74
50	2"	210	Φ165	Φ125	Φ96	4-Φ18	16	4	155	9.92
65	2 1/2"	250	Φ185	Φ145	Φ120	8-Φ18	16	4	170	13.5
80	3"	300	Φ200	Φ160	Φ135	8-Φ18	18	4	200	19.5
100	4"	350	Φ220	Φ180	Φ155	8-Φ18	18	4	270	26.5
125	5"	400	Φ250	Φ210	Φ185	8-Φ18	20	5	335	39
150	6"	460	Φ285	Φ240	Φ210	8-Φ22	20	5	370	56.8
200	8"	570	Φ340	Φ295	Φ265	8-Φ22	22	6	450	83
250	10"	680	Φ405	Φ355	Φ320	12-Φ26	24	6	545	150
300	12"	790	Φ460	Φ410	Φ372	12-Φ26	26	6	585	171

注：重量只包括阀本身重量，不含执行机构及附件重量

Note: The weight only includes the weight of the valve itself, excluding the weight of the actuator and accessories

气动衬氟隔膜阀 ZJHFG/ZSFG-^{0.6}/_{1.6} K/B

Pneumatic fluorine-lined diaphragm valve

安装与维修

1. 产品使用的环境温度为 -30 ~ + 70°C。因为气动薄膜片和活塞的橡胶零件，在过低温度下易硬化变脆，高温时会加速老化。
2. 产品最好正立安装。如安装位置不允许，也可与垂直线成一角度。倾斜安装时，应考虑加设支承架。
3. 手轮机构使用后，必须将伸缩套管恢复到上端（与豁口板靠近位置），否则会影响自动控制。如图二所示。
4. 切断阀安装在管道上之前，应彻底清洗管道系统的杂质和污物，以免切断阀运行部件卡死，或损坏阀座、阀芯密封面等重要零件。
5. 切断阀安装时，介质流向应与调节阀箭头方向一致。

订货须知

1. 产品型号
2. 公称通径 DN，公称压力 PN
3. 介质工作压差和工作温度范围
4. 阀的作用方式：气关式或气开式
5. 附件：电磁阀、阀位反馈器、手轮机构等
6. 其它特殊要求

Installation and maintenance

1. Products using the environment temperature is 30 ~ + 70 °C . Because of pneumatic diaphragm and piston rubber parts, easy to hardening of the brittle at low temperatures, high temperature accelerated ageing.
2. The product is best installed. Such as the installation position does not allow, also can with vertical lines into a point of view. When installation, should consider adding support.
3. The handwheel institutions after use, must return pipe to the upper plate (with gap close to the location), otherwise it will affect the automatic control. As shown in figure 2.
4. Cut-off valve installed on the pipeline before, should be thoroughly clean impurities and dirt of the pipeline system, in order to avoid the cut-off valve stuck running parts, or damage to the valve seat, valve core sealing surface, and other important parts.
5. Cut-off valve installation, medium flow direction should be consistent with the regulator direction arrow.

Ordering instructions

1. The product model
2. Nominal diameter DN, nominal pressure PN
3. The working pressure difference and temperature range
4. The role of valve: gas shut or open
5. Accessories: solenoid valve, valve location feedback device, hand wheel, etc
6. Other special requirements

Class150LB 隔膜阀

公称通径 Nominal Diameter		标准值 Standard value									
DN	NPS	L	D	D1	D2	Z-Φd	b	f	H	H1	W(Kg)
15	1/2"	130	Φ90	Φ60.3	Φ34.9	4-Φ16	8	4	110	270	2.8
20	3/4"	135	Φ100	Φ69.9	Φ42	4-Φ16	8.9	4	115	270	3.5
25	1"	127	Φ110	Φ79.4	Φ50.8	4-Φ16	9.6	4	120	270	3.8
32	1 1/4"	140	Φ115	Φ88.9	Φ63.5	4-Φ16	11.2	4	125	300	6.2
40	1 1/2"	165	Φ125	Φ98.4	Φ73	4-Φ16	12.7	4	135	300	7.74
50	2"	178	Φ150	Φ120.7	Φ92	4-Φ18	14.3	4	155	300	9.92
65	2 1/2"	190	Φ180	Φ139.7	Φ105	4-Φ18	15.9	4	170	380	13.5
80	3"	203	Φ190	Φ152.4	Φ126	4-Φ18	17.5	4	200	460	19.5
100	4"	229	Φ230	Φ190.5	Φ155	8-Φ18	22.3	4	270	460	26.5
125	5"	356	Φ255	Φ215.9	Φ185	8-Φ22	22.3	5	335	660	39
150	6"	394	Φ280	Φ241.3	Φ210	8-Φ22	23.9	5	370	750	56.8
200	8"	457	Φ345	Φ298.5	Φ265	8-Φ22	27	6	450	750	83
250	10"	533	Φ405	Φ362	Φ320	12-Φ26	28.6	6	545	800	150
300	12"	610	Φ485	Φ431.8	Φ372	12-Φ26	30.2	6	585	800	171

注：重量只包括阀本身重量，不含执行机构及附件重量
Note: The weight only includes the weight of the valve itself, excluding the weight of the actuator and accessories

软密封旋塞阀 Soft sealing plug valve

F

衬氟阀门系列
Fluorine Lined Valve Series



结构特点: Structural characteristics:

衬氟旋塞阀是用带通孔的塞体作启闭件，塞体随阀杆转动，以实现启闭动作的阀门。旋塞阀启闭迅速、流体阻力小。基本系列有衬里旋塞阀（全型）和衬套旋塞阀（半衬型）。旋塞阀多用于截断介质流动，也可进行介质分配（三通旋塞阀）。衬氟旋塞阀适用在 - 50°C~150°C 的各种浓度的王水、硫酸、盐酸、氢氟酸和各种有机酸、强酸、强氧化剂，FEP还适用于各种浓度的强碱有机溶剂以及其它腐蚀性气体、液体介质的管路上使用。

Fluorine valve is used with a hole plug for opening and closing parts, plug body with the valve stem rotation, to achieve the opening and closing of the valve action. Plug valves open and close rapidly, fluid resistance small. Basic series lined plug valves (full lining type) and the sleeve plug (half lining type). Plug valves for truncated medium flow, but also medium distribution (three valve). Fluorine valve used in -50°C~150°C with various concentrations of sulfuric acid, hydrochloric acid, aqua regia, hydrofluoric acid and various organic acids, strong acid, strong oxidizing agents, the use of alkali and organic solvent FEP is also suitable for various concentrations and pipeline other corrosive gas, liquid medium.

设计标准

Design standards

设计制造规范: API 599 HG/T3704 GB/T12240
API 599 HG/T3704 GB/T12240

结构长度: GB/T12221 ASME B16.10 HG/T3704
GB/T12221 ASME B16.10 HG/T3704

连接尺寸: GB/T9113 JB/T79 HG/T20592 ASME B16.5
Note: GB/T9113 JB/T79 HG/T20592 ASME B16.5

试验与检验: GB/T13927 API 598
English name: GB/T13927 API 598

性能规范

Performance specifications

压力等级: PN0.6~1.6MPa 150Lb~300Lb
Pressure rating: PN0.6~1.6MPa 150Lb~300Lb

强度试验: 1.5MPa
Strength test: 1.5MPa

密封试验: 1.1MPa
Sealing test: 1.1MPa

气密试验: 0.6MPa
Air tightness test: 0.6MPa

基本型号 Basic model

公称压力PN0.6-1.6(MPa)150Lb~300Lb 公称口径DN15-400 (mm)/in1/2"~16"
Nominal pressure PN0.6-1.6 (MPa) 150Lb~300Lb, nominal diameter DN15-400 (mm)/in1/2"~16"

手动 Manual	X43F(卡套式Sleeve type)	蜗轮传动 Worm gear transmission	X343F(卡套式Sleeve type)	气动 Pneumatic	X643F(卡套式Sleeve type)	电动 Electric	X943F(卡套式Sleeve type)
	X43FO(全衬里Fully lined)		X343FO(全衬里Fully lined)		X643FO(全衬里Fully lined)		X943FO(全衬里Fully lined)
	X43F ₄₆ (全衬里Fully lined)		X343F ₄₆ (全衬里Fully lined)		X643F ₄₆ (全衬里Fully lined)		X943F ₄₆ (全衬里Fully lined)
	X43F ₅₀₁ (全衬里Fully lined)		X343F ₅₀₁ (全衬里Fully lined)		X643F ₅₀₁ (全衬里Fully lined)		X943F ₅₀₁ (全衬里Fully lined)

F 国标气动衬氟旋塞阀 X41F-K/B

Pneumatic fluorine lined plug valve

衬氟阀门系列
Fluorine Lined Valve Series

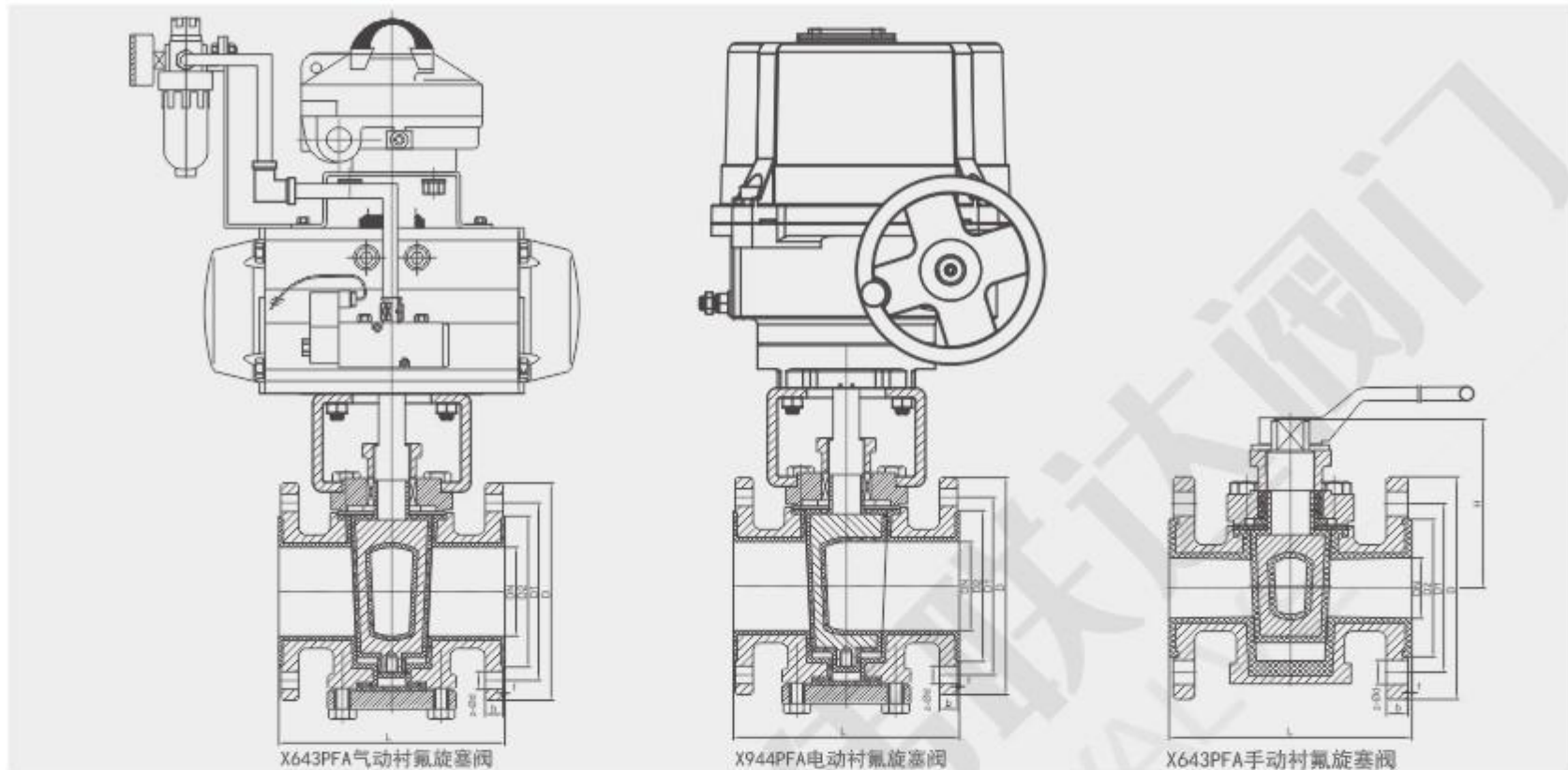

X643PFA气动衬氟旋塞阀

X944PFA电动衬氟旋塞阀

X643PFA手动衬氟旋塞阀

PN10 国标旋塞阀

DN	NPS	L	D	D1	D2	z-Φd	b	f	H	重量 (KG)
20	3/4"	117	Φ105	Φ75	Φ55	4-Φ14	16	4	92	2.2
25	1"	128	Φ115	Φ85	Φ65	4-Φ14	16	4	93	3
32	1 1/4"	140	Φ140	Φ100	Φ75	4-Φ18	16	4	110	3.8
40	1 1/2"	165	Φ145	Φ110	Φ85	4-Φ18	16	4	126.5	6.2
50	2"	180	Φ165	Φ125	Φ96	4-Φ18	16	4	126	9.5
65	2 1/2"	194	Φ185	Φ145	Φ120	8-Φ18	16	4	144	10.5
80	3"	205	Φ200	Φ160	Φ135	8-Φ18	18	4	156	13
100	4"	229	Φ220	Φ180	Φ155	8-Φ18	18	4	175	18
125	5"	260	Φ250	Φ210	Φ185	8-Φ18	20	5	205.5	22
150	6"	267	Φ285	Φ240	Φ210	8-Φ22	20	5	202	31
200	8"	292	Φ340	Φ295	Φ265	8-Φ22	22	6	248	42
250	10"	330	Φ395	Φ350	Φ320	12-Φ22	24	6	288	110
300	12"	356	Φ445	Φ400	Φ372	12-Φ22	26	6	335	200

PN16 国标旋塞阀

DN	NPS	L	D	D1	D2	z-Φd	b	f	H	重量 (KG)
20	3/4"	117	Φ105	Φ75	Φ55	4-Φ14	16	4	92	2.2
25	1"	128	Φ110	Φ85	Φ65	4-Φ14	16	4	93	3
32	1 1/4"	140	Φ115	Φ100	Φ75	4-Φ18	16	4	110	3.8
40	1 1/2"	165	Φ125	Φ110	Φ85	4-Φ18	16	4	126.5	6.2
50	2"	180	Φ150	Φ125	Φ96	4-Φ18	16	4	126	9.5
65	2 1/2"	194	Φ180	Φ145	Φ120	8-Φ18	16	4	144	10.5
80	3"	205	Φ190	Φ160	Φ135	8-Φ18	18	4	156	13
100	4"	229	Φ230	Φ180	Φ155	8-Φ18	18	4	175	18
125	5"	260	Φ255	Φ210	Φ185	8-Φ18	20	5	205.5	22
150	6"	267	Φ280	Φ240	Φ210	8-Φ22	20	5	202	31
200	8"	292	Φ340	Φ295	Φ265	12-Φ22	22	6	248	42
250	10"	330	Φ405	Φ355	Φ320	12-Φ26	24	6	288	110
300	12"	356	Φ460	Φ410	Φ372	12-Φ26	26	6	335	200

注：重量只包括阀本身重量，不含执行机构及附件重量

美标气动衬氟旋塞阀 X41F-K/B Pneumatic fluorine lined plug valve

F

衬氟阀门系列
Fluorine Lined Valve Series

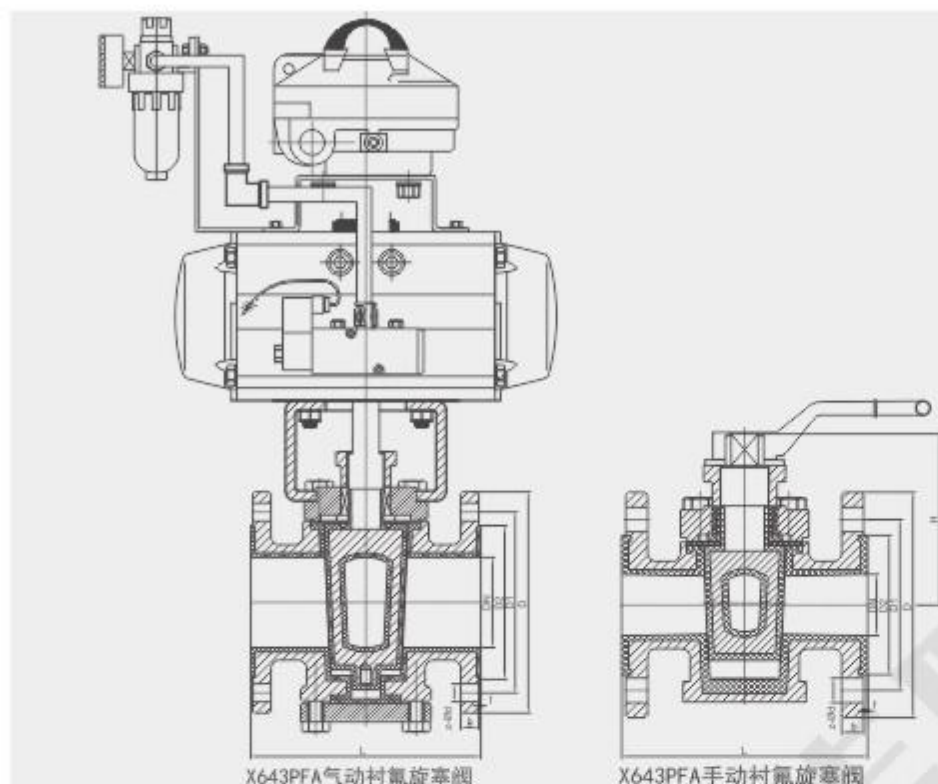

产品特性

设计标准: API599
结构长度: GB/T12221 ASMEB16.10
法兰标准: GB/T 9113.1 JB/T 79.1 ASMEB16.5
公称压力: 1.0~10Mpa、Class150~600
试验与检验: JB/T9092 API598 GB/T13927
驱动方式: 手动、电动、气动等操作方式

Product Features

Design standard: API599
End-to-end dimension: GB/T12221 ASMEB16.10
Flange standard: GB/T 9113.1 JB/T 79.1 ASMEB16.5
Nominal pressure: 1.0~10Mpa, Class150~600
Inspection and testing: JB/T9092 API598 GB/T13927

阀门主要零件材料:

名称 Name	材料 Material		
	碳素钢 Carbon steel	合金钢 Alloy steel	不锈钢 Stainless Steel
阀体/阀盖 Body/bonnet	铸钢 WCB	铬钼铸钢 ZG1CrMo	铬镍钛铸钢 ZG1Cr18Ni9Ti
塞体 Plug body	铸钢 WCB	铬钼铸钢 ZG1CrMo	铬镍钛铸钢 ZG1Cr18Ni9Ti
阀杆 Valve stem			
阀座 Valve seat	增强聚四氟乙烯 PTFE		
V型垫 V-shaped pad	聚四氟乙烯 PTFE		
膜片 Diaphragm	铬镍钛钢 1Cr18Ni9Ti		

Class150LB 气动衬氟旋塞阀

DN	NPS	L	D	D1	D2	z-Φd	b	f	H	重量 (KG)
20	3/4"	117	Φ105	Φ75	Φ55	4-Φ14	15	4	92	2.2
25	1"	128	Φ110	Φ79.4	Φ65	4-Φ16	9.6	4	93	3
32	1 1/4"	140	Φ115	Φ88.9	Φ75	4-Φ16	11.2	4	110	3.8
40	1 1/2"	165	Φ125	Φ98.4	Φ85	4-Φ16	12.7	4	126.5	6.2
50	2"	180	Φ150	Φ120.7	Φ96	4-Φ19	14.3	4	126	9.5
65	2 1/2"	194	Φ180	Φ139.7	Φ120	4-Φ19	15.9	4	144	10.5
80	3"	205	Φ190	Φ152.4	Φ135	4-Φ19	17.5	4	156	13
100	4"	229	Φ230	Φ190.5	Φ155	8-Φ19	22.3	4	175	18
125	5"	260	Φ255	Φ215.9	Φ185	8-Φ22.5	22.3	5	205.5	22
150	6"	267	Φ280	Φ241.3	Φ210	8-Φ22.5	23.9	5	202	31
200	8"	292	Φ340	Φ295	Φ265	12-Φ22	22	6	248	42
250	10"	330	Φ405	Φ355	Φ320	12-Φ26	24	6	288	110
300	12"	356	Φ460	Φ410	Φ372	12-Φ26	26	6	335	200

Class300LB 气动衬氟旋塞阀

DN	NPS	L	D	D1	D2	z-Φd	b	f	H	重量 (KG)
20	3/4"	117	Φ115	Φ82.5	Φ55	4-Φ16	11	4	92	2.2
25	1"	128	Φ125	Φ88.9	Φ65	4-Φ18	13	4	93	3
32	1 1/4"	140	Φ135	Φ98.4	Φ75	4-Φ18	14.5	4	110	3.8
40	1 1/2"	165	Φ155	Φ114.3	Φ85	4-Φ22	16.1	4	126.5	6.2
50	2"	180	Φ165	Φ127	Φ96	8-Φ18	17.7	4	126	9.5
65	2 1/2"	194	Φ190	Φ149.2	Φ120	8-Φ22	21	4	144	10.5
80	3"	205	Φ210	Φ168.3	Φ135	8-Φ22	24	4	156	13
100	4"	229	Φ255	Φ200	Φ155	8-Φ22	27.2	4	175	18
125	5"	260	Φ280	Φ235	Φ185	8-Φ22	29.4	5	205.5	22
150	6"	267	Φ320	Φ269.9	Φ210	12-Φ22	31	5	202	31
200	8"	292	Φ380	Φ330.2	Φ265	12-Φ26	34.7	6	248	42
250	10"	330	Φ445	Φ387.4	Φ320	16-Φ30	41.1	6	288	110
300	12"	356	Φ520	Φ450.8	Φ372	16-Φ33	44.3	6	335	200

注: 重量只包括阀本身重量, 不含执行机构及附件重量

衬氟过滤器

Fluorine-lined filter

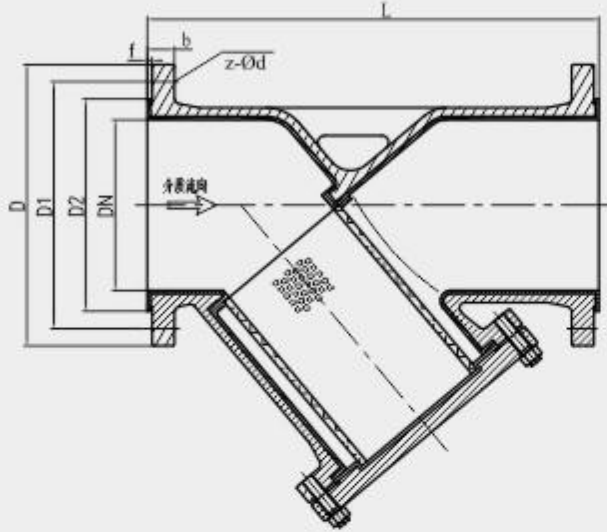

GL41F₄₆Y型过滤器

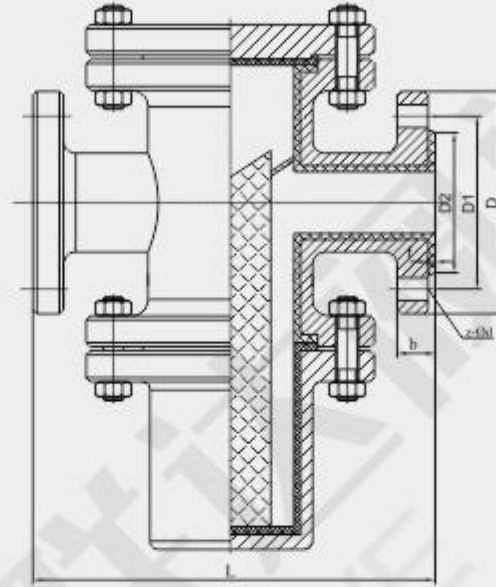

SD46F₄₆衬氟蓝式过滤器

结构特点：

Structural characteristics:

过滤器是输送介质的管道系统不可缺少的一种装置，其作用是过滤介质中的机械杂质，可以对污水中的铁锈、沙粒等进行过滤以保护设备管道上的配件免受磨损和堵塞。

衬氟过滤器是用来清除腐蚀性介质中的杂质，保护泵、阀门及其它设备的正常使用。一般通水网为 20-60 目/cm²，通气网为 40-100 目/cm² 通油网为 100-480 目/cm²。可根据介质相应配置。由于过滤器内壁及滤网均采用耐腐蚀性极强的四氟制成，因此该产品被广泛应用于各种腐蚀性管路中。

A filter is a device pipeline system indispensable transmission medium, its role is mechanical impurities in filter media, the sewage in the rust, sand filter to protect the equipment pipeline parts from wear and clogging.

Fluorine filters are used to remove impurities in corrosive medium, the protection of the normal use of pumps, valves and other equipment. General water network for 20-60 /cm², ventilation network is 40-100 /cm² 100-480 /cm² oil through network. According to the media the corresponding configuration. Because the filter wall and filter screens are with strong corrosion resistance, PTFE, so the products are widely used in all kinds of corrosive pipeline.

设计标准 Design standards	设计制造规范: API 599 HG/T3704 GB/T12240 Design and Manufacturing Specification: API 599 HG/T3704 GB/T12240	性能规范	压力等级: PN0.6~2.5MPa 150Lb Pressure rating: PN0.6~2.5MPa 150Lb
	结构长度: GB/T12221 ASME B16. 10 HG/T3704 Structural length: GB/T12221 ASME B16 10 HG/T3704		强度试验: 1.5MPa Strength test: 1.5MPa
	连接尺寸: GB/T9113 JB/T79 HG/T20592 ASME B16. 5 Connection size: GB/T9113 JB/T79 HG/T20592 ASME B16 five		密封试验: 1.1MPa Sealing test: 1.1MPa
	试验与检验: GB/T13927 API 598 Testing and Inspection: GB/T13927 API 598		气密试验: 0.6MPa Air tightness test: 0.6MPa

基本型号
Basic model

公称压力 (Nominal pressure) PN1.0 ~ 2.5 (MPa) 150Lb 公称通径 (Nominal diameter) DN 20 ~ 500 (mm) /in 3/4 ' ~ 20 '

Y 型过滤器 Y-shaped filter	PO	蓝式过滤器 Blue filter	PO
	F ₄₆		F ₄₆
	F ₅₀₁		F ₅₀₁

衬氟Y型过滤器 Fluorine-lined filter

F

衬氟阀门系列
Fluorine Lined Valve Series

主要零部件材料表：

序号 NO	零件名称 Name	铸钢 Cast steel	不锈钢 Stainless steel		超低碳不锈钢 Ultra low carbon stainless steel	
		C	P	R	PL	RL
1	阀体、阀盖、闸板 Valve body, valve cover, gate plate	WCB	CF8	CF8M	CF3	CF3M
2	过滤网 Filter screen	F4	F4	F4	F4	F4

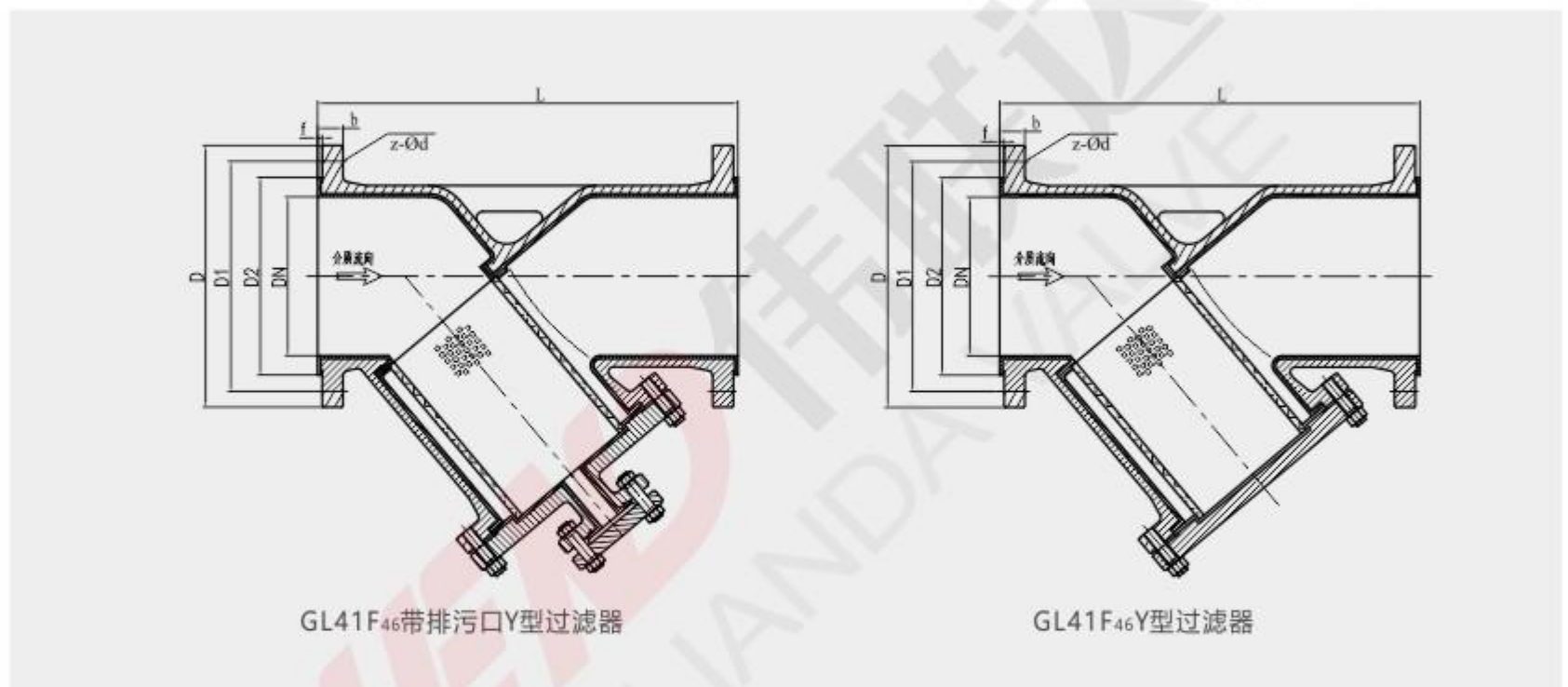

GL41F46带排污口Y型过滤器

GL41F46Y型过滤器

PN10/PN16 衬氟Y型过滤器

公称通径 Nominal diameter		标准值 Standard value							参考值 Reference value		
DN (mm)	NPS (inch)	L	D	D1	D2	f	b	Z-Ød	H1	H2	W(Kg)
PN1.0-1.6(MPa)											
20	3/4	150	105	75	58	2	18	4-Ø14	70	122	3
25	1	160	115	85	68	2	18	4-Ø14	78	135	3.96
32	1 1/4	180	140	100	78	2	18	4-Ø18	86	154	5.81
40	1 1/2	200	150	110	88	2	18	4-Ø18	92	164	8.32
50	2	230	165	125	102	2	18	4-Ø18	102	182	11.8
65	2 1/2	290	185	145	122	2	18	8-Ø18	115	205	11.45
80	3	310	200	160	138	2	20	8-Ø18	135	232	21.22
100	4	350	220	180	158	2	20	8-Ø18	156	263	28.77
125	5	400	250	210	188	2	22	8-Ø28	248	370	40.3
150	6	480	285	240	212	2	22	8-Ø22	285	425	56.88
200	8	495	340	295	268	2	24	8-Ø22	362	530	76

衬氟蓝式过滤器

Fluorine blue filter

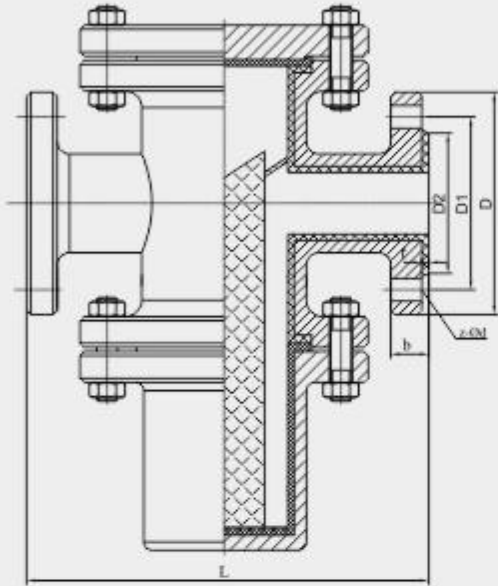

SD46F₄₆衬氟蓝式过滤器

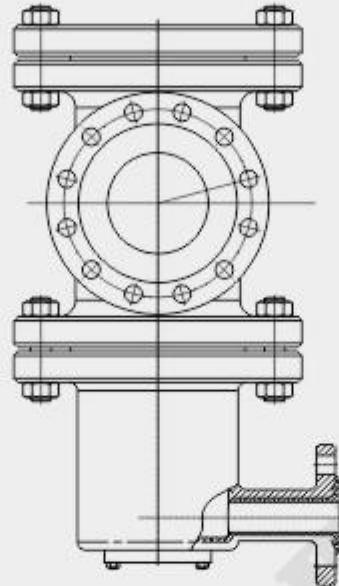

SD46F₄₆衬氟蓝式过滤器
(带侧排污口)

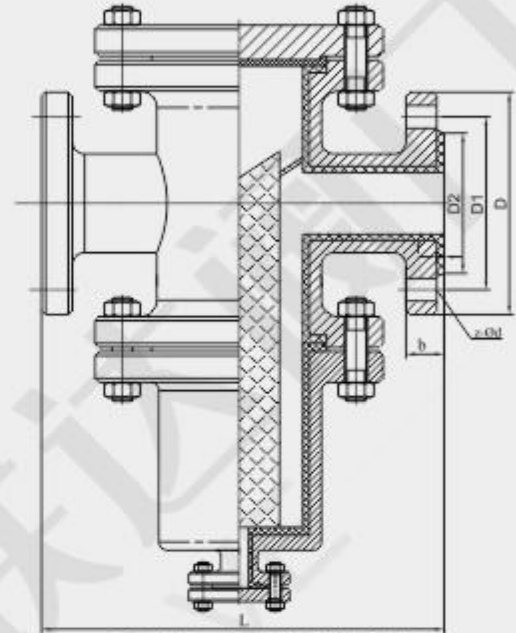

SD46F₄₆衬氟蓝式过滤器
(带底部排污口)

PN10/PN16 衬氟蓝式过滤器

公称通径 Nominal diameter		标准值 Standard value							W(Kg)
DN (mm)	NPS (inch)	L	D	D1	D2	f	b	Z-φd	
PN1.0-1.6(MPa)									
20	3/4	160	105	75	58	2	18	4-φ14	3
25	1	160	115	85	68	2	18	4-φ14	5.66
32	1 1/4	180	140	100	78	2	18	4-φ18	6
40	1 1/2	200	150	110	88	2	18	4-φ18	10.23
50	2	230	165	125	102	2	18	4-φ18	13.4
65	2 1/2	290	185	145	122	2	18	8-φ18	20.42
80	3	310	200	160	138	2	20	8-φ18	26.45
100	4	350	220	180	158	2	20	8-φ18	35.2
125	5	350	250	210	188	2	22	8-φ18	41.15
150	6	360	285	240	212	2	22	8-φ22	60
200	8	400	340	295	268	2	24	12-φ22	80

注：上图所列法兰数值为化工部标准，如需其他标准请在订货时注明。

Note: The flange values listed in the above figure are the standards of the Ministry of Chemical Industry. If other standards are required, please indicate them when ordering.

衬氟视镜

Fluorine-lined sight glass

F

衬氟阀门系列
Fluorine Lined Valve Series

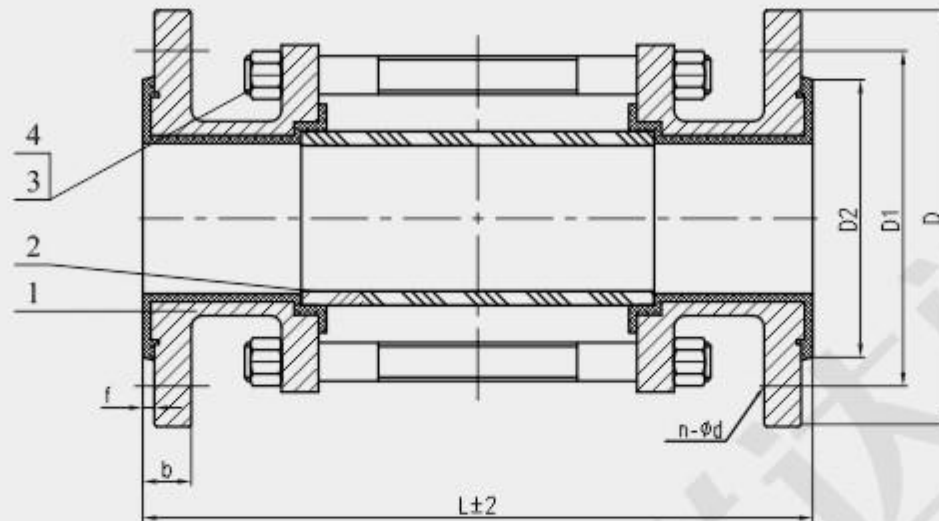

SZ41F₄₆衬氟视镜

图一

结构特点：

Structural characteristics:

衬氟视镜、视镜已经广泛的使用于石油、化工、农药、染化、制酸制碱等行业，能随时观察管道中的液体、气体、蒸汽、润滑油等介质流动情况，起到了监视生产，避免生产过程中事故发生，是管道装置上不可缺少的附件。

设计特点：

石油、化工视镜采用钢衬氟塑料制造，视镜片采用钢化玻璃，可用于强腐蚀性管道中，工作温度可在 -29 度到 200 度之间使用。起到了监视生产，避免生产过程中事故发生，是管道装置上不可缺少的附件。

The use of fluoride glass, as the cup liner has been widely in petroleum, chemical, pesticides, dyes, acid and alkali manufacturing and other industries, can observe the flow condition in pipe liquid, gas, steam, oil and other media at any time, to monitor the production, to avoid the occurrence of accidents in the process of production, is the indispensable pipe device attachment.

Design features:

Petroleum, chemical mirror the use of steel fluorine plastic manufacturing, optic lens uses toughened glass, can be used for strong corrosive pipeline, the working temperature can be used in -29 to 200 degrees. To monitor the production, to avoid the occurrence of accidents in the process of production, is the indispensable accessories plumbing.

PN10衬氟视镜

图一

公称通径 Nominal diameter		标准值 Standard value							参考值 Reference value
DN (mm)	NPS (inch)	L	D	D1	D2	f	b	Z-φd	W(Kg)
PN1.0(MPa)									
25	1	225	115	85	68	2	18	4-φ14	3.77
32	1 1/4	240	140	100	78	2	18	4-φ18	4.3
40	1 1/2	245	150	110	88	2	18	4-φ18	5.66
50	2	250	165	125	102	2	18	4-φ18	6.83
56	2 1/2	255	185	145	122	2	18	8-φ18	9.14
80	3	270	200	160	138	2	20	8-φ18	11.56
100	4	270	220	180	158	2	20	8-φ18	14.8
125	5	290	250	210	188	2	22	8-φ18	18.26
150	6	290	285	240	212	2	22	8-φ22	32

衬氟视镜

Fluorine-lined sight glass

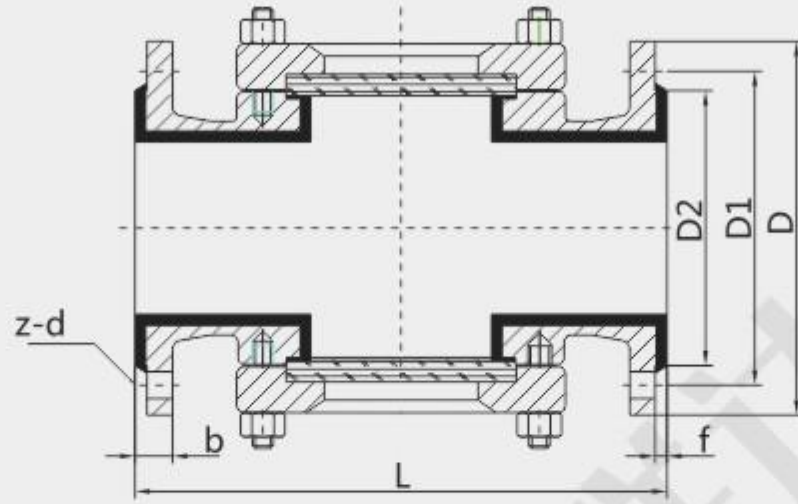

图二

PN10衬氟视镜

图二

公称通径 Nominal diameter		标准值 Standard value							参考值 Reference value	
DN (mm)	NPS (inch)	L	L1	D	D1	D2	f	b	Z-Φd	W(Kg)
PN1.0(MPa)										
15	1/2	160	200	95	65	45	2	16	4-Φ14	3
20	3/4	160	200	105	75	58	2	18	4-Φ14	3.9
25	1	160	200	115	85	68	2	18	4-Φ14	5.5
32	1 1/4	180	260	140	100	78	2	18	4-Φ18	6.12
40	1 1/2	200	260	150	110	88	2	18	4-Φ18	9.04
50	2	230	320	165	125	102	2	18	4-Φ18	12.46
65	2 1/2	290	320	185	145	122	2	18	8-Φ18	16.3
80	3	310	360	200	160	138	2	20	8-Φ18	20.3
100	4	350	360	220	180	158	2	20	8-Φ18	26
125	5	350	440	250	210	188	2	22	8-Φ18	35.2
150	6	360	440	285	240	212	2	22	8-Φ22	47
200	8	400	480	340	295	268	2	24	8-Φ22	55

注：上图所列法兰数值为化工部标准，如需其它标准请在订货时注明。

Note: The flange values listed in the above figure are the standards of the Ministry of Chemical Industry. If other standards are required, please indicate them when ordering.

衬里法兰直管

Lined flange straight pipe

F

衬氟阀门系列
Fluorine Lined Valve Series

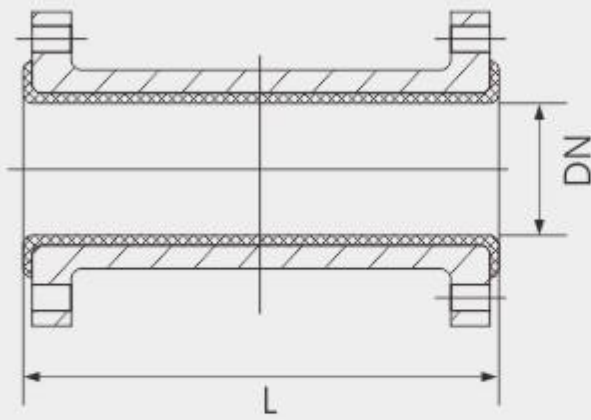

衬里法兰直管

结构特点：

聚四氟乙烯衬里防腐管道经过多年的实际使用，直接影响其使用寿命和性能稳定的因素是温度、压力、介质等。主要用于强腐蚀介质多的工业管道上，作为各种连接方式之用。壳体材料选用碳钢与不锈钢等。

Structural characteristics:

Teflon lined anti-corrosion pipeline through practical use for many years, the direct factors of its service life and stable performance of the temperature, pressure, medium. Mainly used for strong corrosion medium of industrial pipelines, as various connection modes of. Shell material selection of carbon steel and stainless steel etc..

管子衬里Pipe lining

公称通径 Nominal diameter		钢管壁厚 Steel pipe wall thickness t(mm)	衬里厚度 lining thickness T(mm)	长度 length L(mm)	重量/定尺 Weight/Scale Kg/m
DN (mm)	NPS (inch)				
15	1	3	2.5	100-400	4.7
20	1 1/4	3	2.5		6.1
25	1 1/2	3.5	2.5		7.5
32	2	4	4.5	150-500	10.4
40	2 1/2	4	4.5		14.7
50	3	4.5	4.5		16.7
65	4	4.5	5		21.1
80	5	4.5	5		27.4
100	6	5	5		35.4
125	8	6	6	200-800	55
150	10	7	6		88.2
200	12	8	6		104.5

管路附件系列

Pipeline accessories series

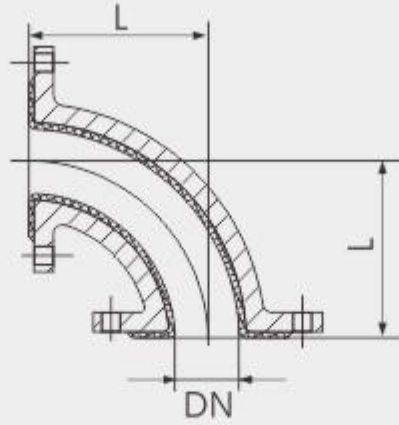

90度弯头 90 degree elbow

DN(mm)	DN(in)	L(mm)	Kg
25	1	98	2.7
32	1 1/4	108	3.2
40	1 1/2	110	4.3
50	2	125	5.7
65	2 1/2	114	6.8
80	3	120	7.3
100	4	150	9.1
125	5	180	12.6
150	6	200	18.5
200	8	225	26.4
250	10	280	36.2
300	12	300	46.6

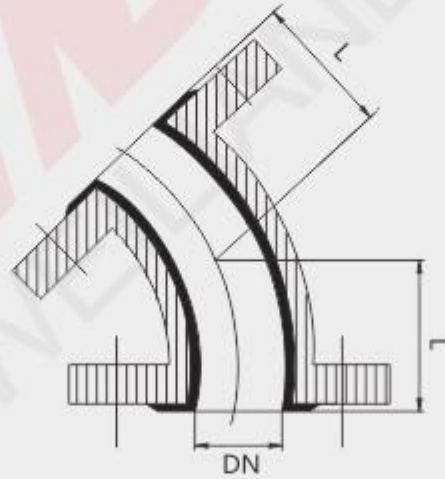

45度弯头 45 degree elbow

DN(mm)	DN(in)	L(mm)	Kg
25	1	62	2.5
32	1 1/4	65	3.4
40	1 1/2	63	3.6
50	2	64	4.3
65	2 1/2	71	6.1
80	3	74	6.37
100	4	85	8.3
125	5	105	12.5
150	6	123	17.3
200	8	158	25.8
250	10	195	41.7
300	12	226	49.1

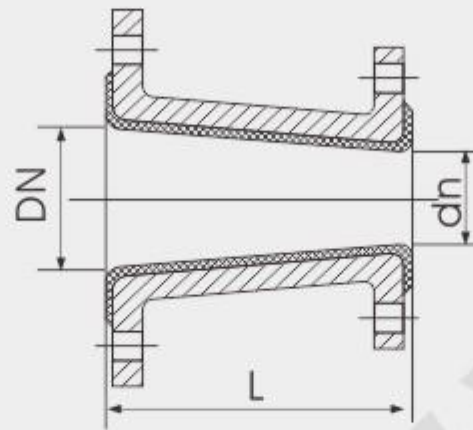

同心异径管

异径管 Reducing pipe

公称通径 Nominal diameter		结构长度 Structure length	参考重量 Reference weight	公称通径 Nominal diameter		结构长度 Structure length	参考重量 Reference weight
Dn×dn	(inch)	L(mm)	Kg	Dn×dn	(inch)	L(mm)	Kg
32×25	1 1/4×1	150	3.7	100×50	4×2	150	7.2
40×32	1 1/2×1 1/4	150	4.4	125×100	5×4	150	10.1
40×25	1 1/2×1	150	3.9	125×80	5×3	150	9.3
50×40	2×1 1/2	150	5.1	125×100	6×5	150	12.2
50×32	2×1 1/4	150	4.9	150×125	6×4	150	11.6
50×25	2×1	150	4.4	150×80	6×3	300	10.5
65×50	2 1/2×2	150	6.6	200×150	8×6	150	16.6
65×40	2 1/2×1 1/4	150	6.4	200×125	8×5	300	20.1
65×25	2 1/2×1	150	5.5	200×100	8×4	300	17.8
80×65	3×1 1/4	150	6.7	250×200	10×8	150	21.2
80×50	3×2	150	5.8	250×150	10×6	300	24.8
80×40	3×1 1/2	150	5.4	250×125	10×5	300	21.7
100×80	4×3	150	7.7	300×250	12×10	150	27.9
100×65	4×2 1/2	150	7.6	300×200	12×8	300	33.8
-	-	-	-	300×150	12×6	300	30.4

管路附件系列

Pipeline accessories series

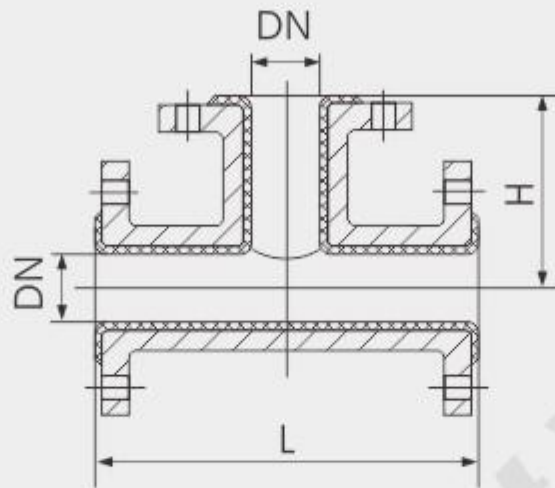

等径三通管

等径/异径三通管 Equal/Reducing Tee

公称通径 Nominal diameter		结构长度 Structure length	中心高 Center height	参考重量 Reference weight	公称通径 Nominal diameter		结构长度 Structure length	中心高 Center height	参考重量 Reference weight
Dn×dn	(inch)	L(mm)	H(mm)	Kg	Dn×dn	(inch)	L(mm)	H(mm)	Kg
25×25	1×1	196	98	3.6	125×125	5×5	346	173	21.4
32×32	1 1/4×1 1/4	216	108	6.3	125×100	5×4	346	173	18.6
32×25	1 1/4×1	216	108	5.2	125×80	5×3	346	173	17.8
40×40	1 1/2×1 1/2	230	115	6.9	150×150	6×6	382	191	28.6
40×32	1 1/2×1 1/4	230	115	6.2	150×125	6×5	382	191	26.9
40×25	1 1/2×1	230	115	5.7	150×100	6×4	382	191	25.7
50×50	2×2	250	125	8.1	200×200	8×8	440	220	40.7
50×40	2×1 1/2	250	125	7.3	200×150	8×6	440	220	38.3
50×32	2×1 1/4	250	125	7.1	200×125	8×5	440	220	36.2
65×65	2 1/2×2 1/2	274	137	11.4	200×100	8×4	440	200	34.5
65×50	2 1/2×2	274	137	10.6	250×250	10×10	514	257	66.7
65×40	2 1/2×1 1/2	274	137	10.1	250×200	10×8	514	257	61.2
80×80	3×3	288	144	12.6	250×150	10×6	514	257	59.3
80×65	3×2 1/2	288	144	12.1	300×300	12×12	570	285	76.6
80×50	3×2	288	144	11.3	300×250	12×10	570	285	74.8
100×100	4×4	312	156	16.2	300×200	12×8	570	285	71.6
100×80	4×3	312	156	15.1	-	-	-	-	-
100×65	4×2 1/2	312	156	14.6	-	-	-	-	-
100×50	4×2	312	156	14.1	-	-	-	-	-