



VINCENT



**CHECK VALVE
SERIES**
止回阀系列

国标旋启式止回阀
GB Swing check valve

H44W^H-16C/P/R_Y

标准

设计与制造按GB/T12236
结构长度按GB/T12221
法兰连接尺寸按JB/T79
检验按JB/T9092

Standards

Design and manufacture as GB/T12236
Face to face dimensions as GB/T12221
End flange dimension as JB/T79
Pressure test as JB/T9092

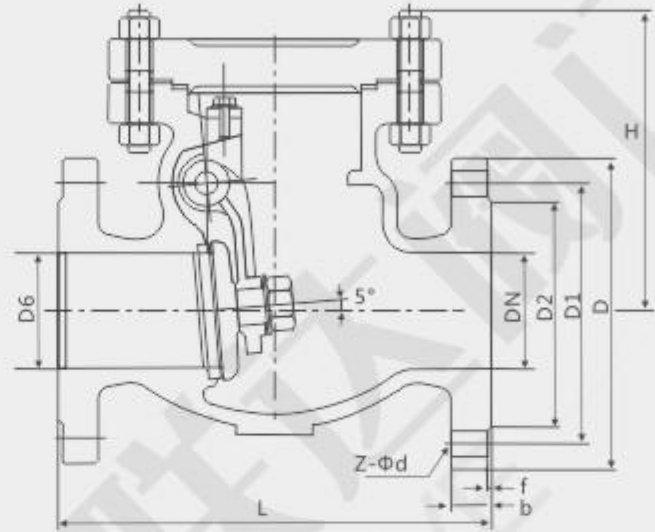

试验压力 Test Pressure

试验项目 Test Item		壳体试验 Shell Test	密封试验 Seal Test	上密封试验 Back Seal Test	气密封试验 Air Seal Test
介质 Medium		水 Water			气 Air
单位 Unit		MPa	MPa	MPa	MPa
公称压力 Nominal Pressure PN(MPa)	1.6	2.4	1.8	1.8	0.5~0.7
	2.5	3.8	2.8	2.8	
	4.0	6.0	4.4	4.4	
	6.4	9.6	7.0	7.0	
	10.0	15.0	11.0	11.0	
	16.0	24.0	18.0	18.0	

主要零件材料 Materials for Main Parts

名称 Name	材料 Material								
阀体/阀盖 Body/Bonnet	CF8	CF3	CF8M	CF3M	WCB	LCB	WC6	WC9	C5
阀瓣 Wedge	CF8	CF3	CF8M	CF3M	WCB	LCB	WC6	WC9	C5
垫片 Gasket	PTFF				石墨 Graphite				
螺栓 Bolt	不锈钢 Stainless Steel				35CrMoA				
螺母 Nut	不锈钢 Stainless Steel				45、35CrMoA				

国标旋启式止回阀
GB Swing check valve

E

止回阀系列
Check Valve Series

PN16 国标旋启式止回阀

公称通径 DN(mm)	尺寸 Dimension(mm)							
	L	D	D1	D2	D6	b-f	z-Φd	H
20	150	105	75	55	-	14-2	4-Φ14	100
25	160	115	85	65	-	14-2	4-Φ14	100
32	180	135	100	78	-	16-2	4-Φ18	105
40	200	145	110	85	-	16-3	4-Φ18	115
50	230	160	125	100	-	16-3	4-Φ18	135
65	290	180	145	120	-	18-3	4-Φ18	140
80	310	195	160	135	-	20-3	8-Φ18	145
100	350	215	180	155	-	20-3	8-Φ18	165
125	400	245	210	185	-	22-3	8-Φ18	250
150	480	280	240	210	-	24-3	8-Φ23	295
200	550	335	295	265	-	26-3	12-Φ23	315
250	650	405	355	320	-	30-3	12-Φ25	430
300	750	460	410	375	-	30-4	12-Φ25	480
350	850	520	470	435	-	34-4	16-Φ25	500
400	950	580	525	485	-	36-4	16-Φ30	520
450	1050	640	585	545	-	40-4	20-Φ30	580
500	1150	705	650	608	-	44-4	20-Φ34	630
600	1350	840	770	718	-	48-5	20-Φ41	780

PN25 国标旋启式止回阀

20	150	105	75	55	-	16-2	4-Φ14	100
25	160	115	85	65	-	16-2	4-Φ14	100
32	180	135	100	78	-	18-2	4-Φ18	105
40	200	145	110	85	-	18-3	4-Φ18	115
50	230	160	125	100	-	20-3	4-Φ18	135
65	290	180	145	120	-	22-3	8-Φ18	140
80	310	195	160	135	-	22-3	8-Φ18	145
100	350	230	190	160	-	24-3	8-Φ23	165
125	400	270	220	188	-	28-3	8-Φ25	250
150	480	300	250	218	-	30-3	8-Φ25	295
200	550	360	310	278	-	34-3	12-Φ25	315
250	650	425	370	332	-	36-3	12-Φ30	430
300	750	485	430	390	-	40-4	16-Φ30	480
350	850	550	490	448	-	44-4	16-Φ34	500
400	950	610	550	505	-	48-4	16-Φ34	520
450	1050	660	600	555	-	50-4	20-Φ34	580
500	1150	730	660	610	-	52-4	20-Φ41	630
600	1350	840	770	718	-	56-5	20-Φ41	780

PN40 国标旋启式止回阀

20	150	105	75	55	51	16-2	4-Φ14	100
25	160	115	85	65	58	16-2	4-Φ14	100
32	180	135	100	78	66	18-2	4-Φ18	105
40	200	145	110	85	76	18-3	4-Φ18	115
50	230	160	125	100	88	20-3	4-Φ18	135
65	290	180	145	120	110	22-3	8-Φ18	140
80	310	195	160	135	121	22-3	8-Φ18	145
100	350	230	190	160	150	24-3	8-Φ23	165
125	400	270	220	188	176	28-3	8-Φ25	250
150	480	300	250	218	204	30-3	8-Φ25	295
200	550	375	320	282	260	38-3	12-Φ30	315
250	650	445	385	345	313	42-3	12-Φ34	430
300	750	510	450	408	364	46-4	16-Φ34	480
350	850	570	510	465	422	52-4	16-Φ34	500
400	950	655	585	535	474	58-4	16-Φ41	520
450	1050	680	610	560	524	60-4	20-Φ41	580
500	1150	755	670	612	576	62-4	20-Φ48	630
600	1350	890	795	730	678	62-5	20-Φ54	780

国标旋启式止回阀
GB Swing check valve

PN63 国标旋启式止回阀

JB/T79

公称通径 DN(mm)	尺寸Size(mm)									重量 Weight (Kg)
	L	D	D1	D2	D6	b-f	F2	Z-Φd	H	
50	300	175	135	105	88	26-3	4	4-23	192	30
65	340	200	160	130	110	28-3	4	8-23	207	41
80	380	210	170	140	121	30-3	4	8-23	207	48
100	430	250	200	168	150	32-3	4.5	8-25	235	72
125	500	295	240	202	176	36-3	4.5	8-30	265	108
150	550	340	280	240	204	38-3	4.5	8-34	297	155
200	650	405	345	300	260	44-3	4.5	12-34	357	217
250	775	470	400	352	313	48-3	4.5	12-41	405	341
300	900	530	460	412	364	54-4	4.5	16-41	465	472
350	1025	595	525	475	422	60-4	5	16-41	514	627
400	1150	670	585	525	474	66-4	5	16-48	568	882
500	1400	800	705	640	576	70-4	5	20-54	620	1027

PN100 国标旋启式止回阀

50	300	195	145	112	88	28-3	4	4-25	192	41
65	340	220	170	138	110	32-3	4	8-25	207	48
80	380	230	180	148	121	34-3	4	8-25	235	72
100	430	265	210	172	150	38-3	4.5	8-30	265	108
125	500	310	250	210	176	42-3	4.5	8-34	313	130
150	550	350	290	250	204	46-3	4.5	12-34	360	217
200	650	430	360	312	260	54-3	4.5	12-41	420	341
250	775	500	430	382	313	60-3	4.5	12-41	480	472
300	900	585	500	442	364	70-4	4.5	16-48	520	520
350	1025	655	560	498	422	76-4	5	16-54	584	830
400	1150	715	620	558	474	80-4	5	16-54	625	1060

PN160 国标旋启式止回阀

50	300	215	165	132	88	36-3	4	8-25	251	49
65	340	245	190	152	110	44-3	4	8-30	282	58
80	380	260	205	168	121	46-3	4	8-30	320	110
100	430	300	240	200	150	48-3	4.5	8-34	356	162
125	500	355	285	238	176	60-3	4.5	8-41	393	214
150	550	390	318	270	204	66-3	4.5	12-41	430	267
200	650	480	400	345	260	78-3	4.5	12-48	470	443
250	750	580	485	425	313	88-3	4.5	12-54	514	610
300	900	665	570	510	364	100-4	4.5	16-54	570	685

PN250 国标旋启式止回阀

50	368	210	160	128	70	40-3	5	8-25	310	63
65	419	260	203	165	97	48-3	5	8-30	346	78
80	470	290	230	190	116	54-3	5	8-34	385	140
100	546	360	292	245	138	66-3	6	8-41	406	210
125	673	385	318	270	170	76-3	6	12-41	534	280
150	705	440	360	305	190	82-3	6	12-45	560	347
200	832	535	440	380	245	92-3	6	12-51	318	575
250	991	670	572	508	319	110-3	6	16-55	673	790

美标旋启式止回阀 ANSI Swing check valve

E

止回阀系列
Check Valve Series

概述

我公司生产的美标止回阀，完全按照美国标准设计制造，结构美观、先进。美标止回阀是指依靠介质本身流动而自动开、闭阀瓣，用来防止介质倒流的阀门，又称逆止阀、单向阀、逆流阀。止回阀属于一种自动阀门，其主要作用是防止介质倒流、防止泵及驱动电动机反转，以及容器介质的泄放。

Overview

The American standard check valves produced by our company are designed and manufactured entirely according to American standards, with a beautiful and advanced structure. American standard check valve refers to a valve that automatically opens and closes the valve disc based on the flow of the medium itself to prevent medium backflow, also known as a check valve, one-way valve, or backflow valve. A check valve is an automatic valve that primarily functions to prevent media backflow, prevent pump and drive motor reversal, and discharge container media.

性能参数 Performance parameter

序号	项目名称	项目名称					
		150(Lb)	300(Lb)	600(Lb)	900(Lb)	1500(Lb)	2500(Lb)
1	公称压力PN (MPa)	2.0	5.0	10.0	15.0	25.0	42.0
2	壳体强度试验压力 Shell strength test pressure (MPa)	常温下公称压力的1.5倍 1.5 Times the nominal pressure at room temperature					
3	高压密封试验压力 High-pressure sealing test pressure (MPa)	常温下工作压力的1.1倍 1.1 Times the nominal pressure at room temperature					
4	常温下工作压力 Nominal pressure at room temperature (MPa)	按ASME B16.34 压力温度额定值 According to ASME B16.34 pressure temperature rating					

产品规范 Product specification

设计标准 Design	结构长度 Structure Length	法兰连接尺寸 Connection flange	试验与检验 Test and Inspection	压力与温度基准 ASME B16.34
BS1868/API6D ASME B16.34	ASME B16.10	ASME B16.5 ASME B16.47A系列	API 598/API 6D	ASME B16.34

主要零件材料 Main components material

零件名称 Part Name	材料名称 Material name					
阀体 Valve body	A216 WCB	A217 WC6	A351 CF8	A351 CF8M	A351 CF3	A351 CF3M
阀盖 Valve cover	A216 WCB	A217 WC6	A351 CF8	A351 CF8M	A351 CF3	A351 CF3M
阀板 Valve plate	A216 WCB	A217 WC6	A351 Cf8	A351 CF8M	A351 CF3	A351 CF3M
密封面 Sealing surface	13Cr/STL	STL	本体/STL	本体/STL	本体/STL	本体/STL
阀轴 Valve shaft	A182 F6a	A182 F11	A182 F304	A182 F316	A182 F304L	A182 F316L
垫片 Shim	304+柔性石墨/软铁 304+flexible graphite/soft iron	304+柔性石墨/F304 304+flexible graphite/F304	304+柔性石墨/F304 304+flexible graphite/F304	316+柔性石墨/F316 316+flexible graphite/F316	304L+柔性石墨/F304L 304L+flexible graphite/F304L	316L+柔性石墨/F316L 316L+flexible graphite/F316L
螺栓 Bolt	A193 B7	A193 B16	A193 B8	A193 B8M	A193 B8	A193 B8M
螺母 Nut	A194 2H	A194 4	A194 8	A194 8M	A194 8	A194 8M
使用温度 Operating temperature	-29~425°C	-29~540°C	-46~425°C	-46~425°C	-46~425°C	-46~425°C
适用介质 Applicable medium	水、蒸汽、油品等 Water, steam, oil, etc	水、蒸汽等 Water, steam, etc	硝酸类弱腐蚀介质 Nitric acid weakly corrosive medium	硝酸类弱腐蚀介质 Nitric acid weakly corrosive medium	硝酸类弱腐蚀介质 Nitric acid weakly corrosive medium	硝酸类弱腐蚀介质 Nitric acid weakly corrosive medium

美标旋启式止回阀
ANSI Swing check valve

H44^H_V-150Lb

标准

设计与制造按 API 6D
结构长度按 ASME B16.10
法兰连接尺寸按 ASME B16.5, ANSI B16.5
检验按 API 598

Standards

Design and manufacture as API 6D
Face to face dimensions as ASME B16.10
End flange dimension as ASME B16.5, ANSI B16.5
Pressure test as API 598

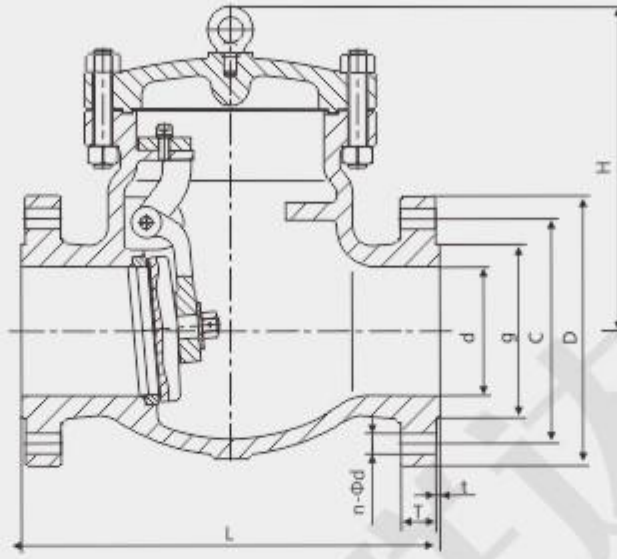

Class 150LB 美标旋启式止回阀

尺寸 Dimension(mm)

in	d	L	D	C	g	T	t	H	n-Φ
1/2"	15	108	89	60.5	35	12	1.6	-	4-15
3/4"	20	117	98	70.0	43	12	1.6	-	4-15
1"	25	127	108	79.5	51	12	1.6	-	4-15
1-1/4"	32	140	117	89	64	13	1.6	-	4-15
1-1/2"	40	165	127	98.5	73	15	1.6	-	4-15
2"	50	203	152	120.5	92	16	1.6	161	4-19
2-1/2"	65	216	178	139.5	105	18	1.6	180	4-19
3"	80	241	190	152.5	127	19	1.6	190	4-19
4"	100	292	229	190.5	157	24	1.6	203	8-19
5"	125	330	254	216	186	24	1.6	229	8-22
6"	150	356	279	241.5	216	26	1.6	257	8-22
8"	200	495	343	298.5	270	29	1.6	292	8-22
10"	250	622	406	362	324	31	1.6	355	12-25
12"	300	698	483	432	381	32	1.6	396	12-25
14"	350	787	533	476	413	35	1.6	445	12-29
16"	400	864	597	540	470	37	1.6	490	16-29
18"	450	978	635	578	533	40	1.6	520	16-32
20"	500	978	698	635	584	43	1.6	546	20-32
24"	600	1295	813	749.5	692	49	1.6	880	20-35
26"	650	1295	786	744.5	711	41	1.6	910	36-22
28"	700	1448	837	795.5	762	44	1.6	935	40-22
30"	750	1524	887	846.0	813	44	1.6	970	44-22

美标旋启式止回阀
ANSI Swing check valve

E

止回阀系列
Check Valve Series

Class 300LB 美标旋启式止回阀

尺寸 Dimension(mm)									
in	d	L	D	C	g	T	t	H	n-Φ
1/2"	15	152	95	66.5	35	15	16	-	4-15
3/4"	20	178	117	82.5	43	16	16	-	4-19
1"	25	203	124	89	51	18	16	-	4-19
1-1/4"	32	216	133	98.5	63	19	16	-	4-19
1-1/2"	40	229	156	114.5	73	21	16	-	4-22
2"	50	267	165	127	92	22	16	178	8-19
2	65	292	190	149	105	25	16	190	8-22
3/2"	80	318	210	168	127	29	16	216	8-22
4"	100	356	254	200	157	32	16	241	8-22
5"	125	400	279	235	186	35	16	267	8-22
6"	150	444	318	270	216	37	16	305	12-22
8"	200	533	381	330	270	41	16	368	12-25
10"	250	622	444	387.5	324	48	16	394	16-29
12"	300	711	521	451	381	51	16	445	16-32
14"	350	838	584	514.5	413	54	16	470	20-32
16"	400	864	648	571.5	470	57	16	533	20-35
18"	450	978	711	628.5	533	60	16	584	24-35
20"	500	1016	775	686	584	64	16	610	24-35
24"	600	1346	914	813	692	70	16	900	24-41

Class 600LB 美标旋启式止回阀

2"	50	292	165	127	92	33	6.4	203	8-19
2-1/2"	65	330	190	149	105	36	6.4	229	8-22
3"	80	356	210	168	127	39	6.4	235	8-22
4"	100	432	273	216	157	45	6.4	286	8-25
5"	125	508	330	266.5	186	52	6.4	292	8-29
6"	150	559	356	292	216	55	6.4	330	12-29
8"	200	660	419	349	270	63	6.4	381	12-32
10"	250	787	508	432	324	71	6.4	457	16-35
12"	300	838	559	489	381	74	6.4	584	20-35
14"	350	889	603	527	413	77	6.4	635	20-38
16"	400	991	686	603	470	84	6.4	684	20-41
18"	450	1092	743	654	533	90	6.4	752	20-44
20"	500	1194	813	724	584	96	6.4	975	24-44

国标升降式止回阀
GB Lift check valve

H41^H_W-16C/P/R

标准

设计与制造按GB/T12235
结构长度按GB/T12221
法兰连接尺寸按JB/T79
检验按JB/T9092

Standards

Design and manufacture as GB/T12235
Face to face dimensions as GB/T12221
End flange dimension as JB/T79
Pressure test as JB/T9092

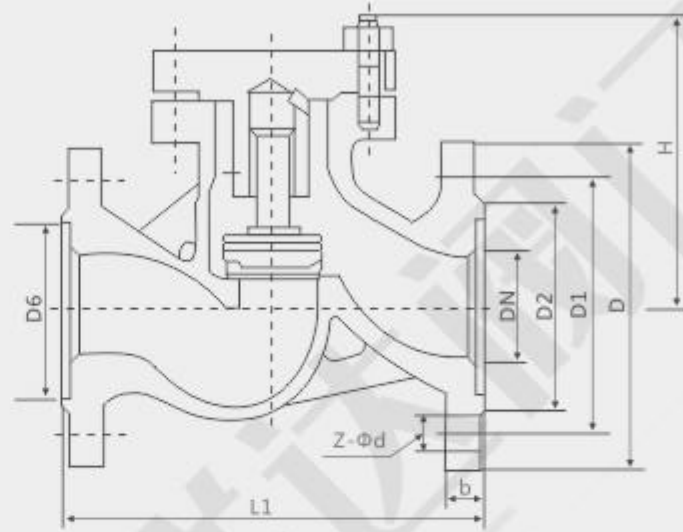

试验压力 Test Pressure

试验项目 Test Item	壳体试验 Shell Test	密封试验 Seal Test	上密封试验 Back Seal Test	气密封试验 Air Seal Test
介质 Medium	水 Water			气 Air
单位 Unit	MPa	MPa	MPa	MPa
公称压力 Nominal Pressure PN(MPa)	1.6	2.4	1.8	0.5~0.7
	2.5	3.8	2.8	
	4.0	6.0	4.4	
	6.4	9.6	7.0	
	10.0	15.0	11.0	
	16.0	24.0	18.0	

主要零件材料 Materials for Main Parts

名称 Name	材料 Material								
阀体/阀盖 Body/Bonnet	CF8	CF3	CF8M	CF3M	WCB	LCB	WC6	WC9	C5
阀瓣 Wedge	CF8	CF3	CF8M	CF3M	WCB	LCB	WC6	WC9	C5
垫片 Gasket	PTFF				石墨 Graphite				
螺栓 Bolt	不锈钢 Stainless Steel				35CrMoA				
螺母 Nut	不锈钢 Stainless Steel				45、35CrMoA				

国标升降式止回阀
GB Lift check valve

E

止回阀系列
Check Valve Series

PN16 国标升降式止回阀

公称通径 DN(mm)	尺寸 Dimension(mm)								
	L	D	D1	D2	D6	b-f	f1	z-Φd	H
15	130	95	65	45	-	14-2	-	4-Φ14	90
20	150	105	75	55	-	14-2	-	4-Φ14	105
25	160	115	85	65	-	14-2	-	4-Φ14	115
32	180	135	100	78	-	16-2	-	4-Φ18	120
40	200	145	110	85	-	16-3	-	4-Φ18	130
50	230	160	125	100	-	16-3	-	4-Φ18	140
65	290	180	145	120	-	18-3	-	4-Φ18	150
80	310	195	160	135	-	20-3	-	8-Φ18	170
100	350	215	180	155	-	20-3	-	8-Φ18	185
125	400	245	210	185	-	22-3	-	8-Φ18	195
150	480	280	240	210	-	24-3	-	8-Φ23	225
200	600	335	295	265	-	26-3	-	12-Φ23	250
250	650	405	355	320	-	30-3	-	12-Φ25	270
300	750	460	410	375	-	30-3	-	12-Φ25	300

PN25 国标升降式止回阀

15	130	95	65	45	-	16-2	-	4-Φ14	90
20	150	105	75	55	-	16-2	-	4-Φ14	105
25	160	115	85	65	-	16-2	-	4-Φ14	115
32	180	135	100	78	-	18-2	-	4-Φ18	120
40	200	145	110	85	-	18-3	-	4-Φ18	130
50	230	160	125	100	-	20-3	-	4-Φ18	140
65	290	180	145	120	-	22-3	-	8-Φ18	150
80	310	195	160	135	-	22-3	-	8-Φ18	170
100	350	230	190	160	-	24-3	-	8-Φ23	185
125	400	270	220	188	-	28-3	-	8-Φ25	195
150	480	300	250	218	-	30-3	-	8-Φ25	225
200	600	360	310	278	-	34-3	-	12-Φ25	250
250	650	425	370	335	-	36-3	-	12-Φ30	270
300	750	485	430	390	-	40-4	-	16-Φ30	300

PN40 国标升降式止回阀

25	160	115	85	65	58	16-2	4	4-Φ14	115
32	180	135	100	78	66	18-2	4	4-Φ18	120
40	200	145	110	85	76	18-3	4	4-Φ18	130
50	230	160	125	100	88	20-3	4	4-Φ18	140
65	290	180	145	120	110	22-3	4	8-Φ18	150
80	310	495	160	135	121	22-3	4	8-Φ18	170
100	350	230	190	160	150	24-3	4.5	8-Φ23	185
125	400	270	220	188	176	28-3	4.5	8-Φ25	195
150	480	300	250	218	204	30-3	4.5	8-Φ25	225
200	600	375	320	282	260	38-3	4.5	12-Φ30	250

PN64 国标升降式止回阀

15	170	105	75	55	40	18-2	4	4-Φ14	110
20	190	125	90	68	51	20-2	4	4-Φ18	125
25	210	135	100	78	58	22-2	4	4-Φ18	152
32	230	150	110	82	66	24-2	4	4-Φ23	168
40	260	165	125	95	76	24-3	4	4-Φ23	170
50	300	175	135	105	88	26-3	4	4-Φ23	188
65	340	200	160	130	110	28-3	4	8-Φ23	205
80	380	210	170	140	121	30-3	4	8-Φ23	230
100	430	250	200	168	150	32-3	4.5	8-Φ25	280
125	500	295	240	202	176	36-3	4.5	8-Φ30	300
150	550	340	280	240	204	38-3	4.5	8-Φ34	350
200	650	405	345	300	260	44-3	4.5	12-Φ34	400

立式止回阀

Vertical check valve

16
H42H-25C、P、R
40

用途和性能规范 Purpose and performance specifications

本阀门用于工业管道上作阻止介质逆流的装置。

This valve is used as a device to prevent reverse flow of medium on industrial pipelines.

性能规范 Performance specifications:

试验压力 Test pressure: 公称压力 (MPa) 1.6/2.5/4.0;

壳体试验 Shell test: 2.4/3.8/6.0;

密封试验 Sealing test: 1.8/2.8/4.4;

阀体材料 Valve body material: WCB(C)/CF8(P)/CF8M(R)/WC6 /WC9;

工作温度 Working temperature: $\leq 425/\leq 100/\leq 100/\leq 550/\leq 550$;

适用介质: 水、蒸汽、油品、硝酸类、醋酸类。

Applicable media: water, steam, oil, nitric acid, acetic acid.

执行标准 Executive standard:

设计制造 Design and manufacturing: GB12235

结构长度 Structure length: GB12221

连接法兰 Connecting flange: JB/T79

试验与检验 Testing and Inspection: JB/T9092

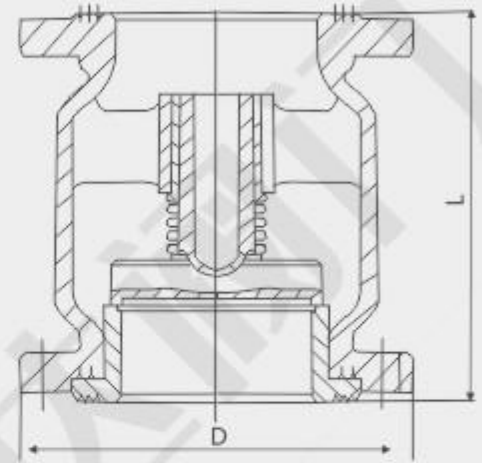

PN16 立式止回阀

公称直径 DN(mm)	尺寸 Dimension(mm)					
	L	D	D1	D2	b-f	z-φd
15	80	95	65	45	14-2	4-φ14
20	95	105	75	55	14-2	4-φ14
25	105	115	85	65	14-2	4-φ14
32	150	135	100	78	16-2	4-φ18
40	160	145	110	85	16-3	4-φ18
50	170	160	125	100	16-3	4-φ18
65	180	180	145	120	18-3	4-φ18
80	200	195	160	135	20-3	8-φ18
100	210	215	180	155	20-3	8-φ18
125	275	245	210	185	22-3	8-φ18
150	300	280	240	210	24-3	8-φ23
200	380	335	295	265	26-3	12-φ23
250	450	405	355	320	30-3	12-φ25

PN25 立式止回阀

公称直径 DN(mm)	尺寸 Dimension(mm)					
	L	D	D1	D2	b-f	Z-φd
15	80	95	65	45	16-2	4-φ14
20	95	105	75	55	16-2	4-φ14
25	105	115	85	65	16-2	4-φ14
32	150	135	100	78	18-2	4-φ18
40	160	145	110	85	18-2	4-φ18
50	170	160	125	100	20-3	4-φ18
65	180	180	145	120	22-3	8-φ18
80	200	195	160	135	22-3	8-φ18
100	210	230	190	160	24-3	8-φ23
125	275	270	220	188	28-3	8-φ25
150	300	300	250	218	30-3	8-φ25
200	380	360	310	278	34-3	12-φ25
250	450	425	370	335	36-3	12-φ30

对夹式止回阀
Wafer check valve

E

止回阀系列
Check Valve Series

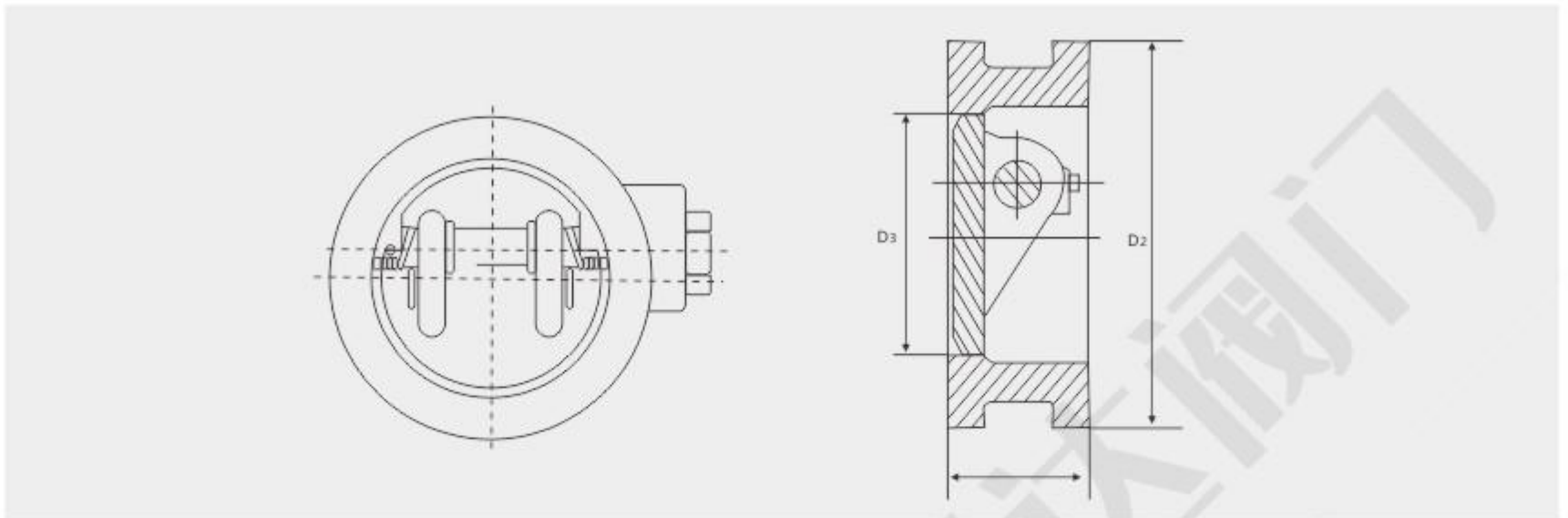

主要技术参数Main technique parameter

型号 Model	公称压力 PN(MPa)	试验压力PS(MPa)		工作温度 Working temperature (°C)	适用介质 Applicable medium
		壳体Case	密封Seal		
H77X H77H H77Y H77W	1.0	常温下公称压力的1.5倍 1.5 Times the nominal pressure at room temperature	常温下公称压力的1.1倍 1.1 Times the nominal pressure at room temperature	软密封: <80 硬密封: <450 Soft seal: <80 Hard seal: <450	水、气体、油品、硝酸等 Water, gas, oil, nitric acid, etc.
	1.6				
	2.5				
	4.0				
	6.4				

主要零件材料Main parts material

零件名称 Part name	材料Material				
	H77X-10C, 25 16, 40	H77H-16C, 40 25, 64	H77Y-25, 64I	H77W-16C, 25 25C, 40	H7W-10P, 25P 16P, 40P
阀体、蝶板Body, disc	铸钢Cast steel WCB		铬钼钢 Cr-Mo steel	铸钢Cast steel WCB	0Cr18Ni90
阀杆Stem	2Cr13	0Cr18Ni9		2Cr13	
阀体密封圈Body Seal	-	堆焊合金焊 Built-up welding alloy welds	堆焊合金焊 Built-up welding alloy welds	-	-
助关弹簧Help off spring	0Cr18Ni9	耐热合金Heat-resistant alloy			0Cr18Ni90

主要外形尺寸Main external dimension

公称通径 DN(mm)	L	D2	D3		公称通径 DN(mm)	L	D2	D3	
			H77X	H77H H77Y H77W				H77X	H77H H77Y H77W
50	43	100	43	46	400	140	485	376	390
80	64	135	71	80	450	152	545	427	427
100	64	155	91.5	94	500	152	608	479	490
125	70	185	115	118	600	178	718	579	588
150	76	210	141	145	700	229	800	675	686
200	89	265	191	200	800	241	905	774	784
250	114	320	230	250	900	241	1005	875	-
300	114	375	290	300	1000	300	1115	974	-
350	127	435	340	340	1200	350	1325	1164	-

H71型对夹式不锈钢止回阀

H71 type wafer stainless steel check valve

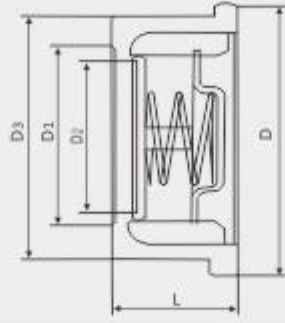

PN10/16 对夹式不锈钢止回阀

公称通径 DN(mm)	尺寸(mm)			重量 Weight(Kg)	配管法兰 (供参考) Piping flange (for reference)			
	L	d	A		螺栓孔中心圆直径D1 Bolt hole center circle diameter	螺栓数量 Number of bolts	螺栓直径D Bolt diameter D	螺栓长度L1 Bolt length L1
15	16	45	18	0.12	65	4	M12	75
20	19	55	25	0.24	75	4	M12	90
25	22	65	32	0.34	85	4	M12	90
32	28	78	38	0.53	100	4	M16	100
40	32	85	45	0.80	110	4	M16	105
50	40	100	57	1.2	125	4	M16	125
65	46	120	73	2.2	145	4	M16	130
80	50	135	89	3.1	160	8	M16	135
100	60	155	108	5.7	180	8	M16	150
125	90	185	133	10	210	8	M16	180
150	106	210	159	14	240	8	M20	210
200	140	265	219	24	295	12	M20	240
250	160	320	273	35	355	12	M20	260

PN25 对夹式不锈钢止回阀

15	16	45	18	0.12	65	4	M12	80
20	19	55	25	0.24	75	4	M12	90
25	22	65	32	0.34	85	4	M12	90
32	28	78	38	0.53	100	4	M16	110
40	32	85	45	0.80	110	4	M16	115
50	40	100	57	1.2	125	4	M16	125
65	46	120	73	2.2	145	8	M16	135
80	50	135	89	3.1	160	8	M16	145
100	60	160	108	7.0	190	8	M20	160
125	90	188	133	12	220	8	M22	205
150	106	218	159	15	250	8	M22	225
200	140	278	219	26	310	12	M22	260
250	160	332	273	40	370	12	M27	280

PN40 对夹式不锈钢止回阀

15	16	45	18	15	65	4	M12	80
20	19	55	25	19	75	4	M12	90
25	22	65	32	24	85	4	M12	90
32	28	78	38	31	100	4	M16	110
40	32	85	45	39	110	4	M16	115
50	40	100	57	48	125	4	M16	125
65	46	120	73	63	145	8	M16	135
80	50	135	89	78	160	8	M16	145
100	60	160	108	98	190	8	M20	160
125	90	188	133	123	220	8	M22	205
150	106	218	159	148	250	8	M22	225
200	140	282	219	248	320	12	M27	275
250	160	345	273	198	385	12	M30	295

H74型对夹式不锈钢止回阀 H74 type wafer stainless steel check valve

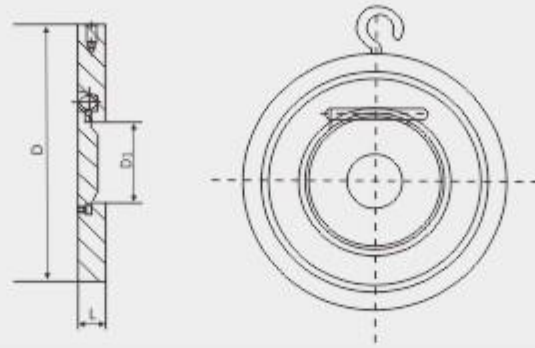

PN10 H74对夹式不锈钢止回阀

公称通径DN(mm)	尺寸 (mm)			配管法兰 (供参考) Piping flange (for reference)		
	L	d	D1	螺栓孔中心圆直径D1 Bolt hole center circle diameter	螺栓数量 Number of bolts	螺栓直径D Bolt diameter D
50	14.5	100	25	125	4	M16
60	14.5	120	38	145	4	M16
80	14.5	135	46	160	4	M16
100	14.5	155	71.5	180	8	M16
125	16	185	95	210	8	M16
150	19	210	114	240	8	M20
200	29	265	140	295	8	M20
250	29	320	188	350	12	M20
300	38	368	216	400	12	M20
350	41	428	263	460	16	M20
400	51	482	305	515	16	M24
450	51	532	356	565	20	M24
500	65	585	406	620	20	M24
600	70	685	482	725	20	M27

PN16 对夹式不锈钢止回阀

50	14.5	100	25	125	4	M16
60	14.5	120	38	145	4	M16
80	14.5	135	46	160	8	M16
100	14.5	155	71.5	180	8	M16
125	16	185	95	210	8	M16
150	19	210	114	240	8	M20
200	29	265	140	295	12	M20
250	29	320	188	355	12	M24
300	38	375	216	410	12	M24
350	41	435	263	470	16	M24
400	51	485	305	525	16	M27
450	51	545	356	585	20	M27
500	65	608	406	650	20	M30
600	70	718	482	770	20	M33

PN25 对夹式不锈钢止回阀

50	14.5	100	25	125	4	M16
60	14.5	120	38	145	8	M16
80	14.5	135	46	160	8	M16
100	14.5	160	71.5	190	8	M20
125	16	188	95	220	8	M24
150	19	218	114	250	8	M24
200	29	278	140	310	12	M24
250	29	332	188	370	12	M27
300	38	390	216	430	16	M27
350	41	448	263	490	16	M30
400	51	505	305	550	16	M33
450	51	555	356	600	20	M33
500	65	610	406	660	20	M33
600	70	718	482	770	20	M36

PN40 对夹式不锈钢止回阀

50	14.5	100	51	125	4	M16
60	14.5	120	65	145	8	M16
80	14.5	135	80	160	8	M16
100	14.5	160	105	190	8	M20
125	16	188	127	220	8	M24
150	19	218	152	250	8	M24
200	29	282	203	320	12	M27
250	29	345	254	385	12	M30
300	38	408	305	405	16	M30
350	41	465	350	510	16	M33
400	51	535	400	585	16	M36
450	51	560	450	610	20	M36
500	65	612	500	670	20	M39
600	70	750	600	795	20	M45

H76型对夹式不锈钢止回阀

H76 type wafer stainless steel check valve

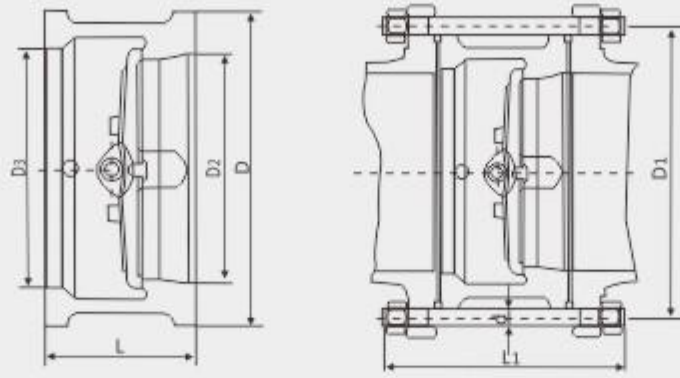

PN10 H76对夹式不锈钢止回阀

公称口径 DN(mm)	尺寸 (mm)				重量 Weight(Kg)	配管法兰 (供参考) Piping flange (for reference)			
	L	d	D3	D2		螺栓孔中心圆直径D1 Bolt hole center circle diameter	螺栓数量 Number of bolts	螺栓直径D Bolt diameter D	螺栓长度L1 Bolt length L1
40	60	96	46	41	2	110	4	M16	150
50	60	109	56	51	2	125	4	M16	150
65	67	129	73	65	3	145	4	M16	155
80	73	144	88	80	4	160	8	M16	160
100	73	164	108	102	6	180	8	M16	165
125	83	194	132	127	8	210	8	M16	180
150	98	220	160	152	12	240	8	M20	205
200	127	275	210	203	24	295	8	M20	235
250	146	330	266	254	35	350	12	M20	255
300	181	380	310	305	48	400	12	M20	290
350	184	440	355	350	78	460	16	M20	295
400	198	493	405	400	106	515	16	M24	310
450	203	543	455	450	135	565	20	M24	325
500	219	598	505	500	165	620	20	M24	345
600	222	698	605	600	260	725	20	M24	355
700	305	811	700	695	360	840	24	M27	440
800	305	918	800	796	540	950	24	M30	450
900	368	1018	903	898	620	1050	28	M30	520
1000	432	1124	1055	1050	880	1160	28	M33	590
1200	524	1340	1205	1200	880	1380	32	M36	695

PN16 H76对夹式不锈钢止回阀

40	60	96	46	41	2	110	4	M16	150
50	60	109	56	51	2	125	4	M16	150
65	67	129	73	65	3	145	4	M16	155
80	73	144	88	80	4	160	8	M16	160
100	73	164	108	102	6	180	8	M16	165
125	83	194	132	127	8	210	8	M16	180
150	98	220	160	152	13	240	8	M20	205
200	127	275	210	203	24	295	12	M20	235
250	146	333	266	254	37	355	12	M24	265
300	181	288	310	305	50	410	12	M24	305
350	184	448	355	350	80	470	16	M24	310
400	198	498	405	400	110	525	16	M27	330
450	203	558	455	450	145	585	20	M27	345
500	219	630	505	500	180	650	20	M30	370
600	222	734	605	600	280	770	20	M33	380
700	305	802	700	695	380	840	24	M33	470
800	305	912	800	796	560	950	24	M36	475
900	368	1012	903	898	640	1050	28	M36	545
1000	432	1126	1055	1050	900	1170	28	M39	620
1200	524	1340	1205	1200	1400	1390	32	M45	735

PN25 H76对夹式不锈钢止回阀

40	60	96	46	41	2	110	4	M16	150
50	60	109	56	51	2	125	4	M16	150
65	67	129	73	65	3	145	4	M16	160
80	73	144	88	80	4	160	8	M16	170
100	73	170	108	102	6	190	8	M20	180
125	83	198	132	127	8	220	8	M24	205
150	98	228	160	152	14	250	8	M24	220
200	127	288	210	203	27	310	12	M24	255
250	146	343	266	254	42	370	12	M27	285
300	181	403	310	305	54	430	12	M27	325
350	184	460	355	350	86	490	16	M30	340
400	198	520	405	400	120	550	16	M33	360
450	203	565	455	450	150	600	20	M33	375
500	219	622	505	500	200	660	20	M33	395
600	222	732	605	600	340	770	20	M36	410
700	305	831	700	695	400	875	24	M39	500
800	305	942	800	796	580	990	24	M45	520
900	368	1040	903	898	660	1090	28	M45	590
1000	432	1155	1055	1050	960	1210	28	M52	675
1200	524	1365	1205	1200	1440	1420	32	M52	790